



SIEMENS

automotive system group

Engine Management System

HMC_V6

MS 42



17-12-1997

SW Version : 650H0000

Identification No : 657765.49.0x

Document: **Basic SW Inputs and Outputs**

Project: **Engine Management System**
HMC_V6

Version: a

Date: 17-Dec-97

Number of pages: 98

Revision Code-No.: 153589 from 18.12.97

Construction protocol-No.:

Software version: 650H0000

	Name	Department	Phone	Date	Sign
Author	Müller O.	AT PT SI TSA 11	3211	09.12.97	
1. Check	Pioch O.	AT PT SI TSA 11	3212	09.12.97	
2. Check	Gessner S.	AT PT SI TSA 11	5398	09.12.97	
Responsible	Brückner D.	AT PT SI TSA 16	4279	09.12.97	

Version list

Proprietary data, company confidential. All rights reserved. Contine a titre de secret d'entreprise. Tous droits réservés. Comunicado como segredo empresarial. Reservados todos os direitos. Confidado como secreto industrial. Nos reservamos todos los derechos.

Weitergabe sowie Vervielfältigung dieser Unterlage, Wertung und Mitteilung ihres Inhalts nicht gestattet, soweit nicht ausdrücklich zugestanden. Zuwiderhandlungen verpflichten zu Schadensersatz. Alle Rechte vorbehalten, insbesondere für den Fall der Patenterteilung oder GM-Eintragung

Version	Date	Author	Comment, Description

Editor:	Müller O.	17-Dec-97	Basic SW Inputs and Outputs	HMC_V6
Version:	a 153589 from 18.12.97		657765.49.02	
File:	CHAP_2.DOC	650H0000		Page 2 / 98

Table of contents

Page

1	Acquisition of Inputs	16
1.1	Analog Inputs	16
1.1.1	Acquisition of mass air - flow	18
1.1.1.1	Basic software	18
1.1.1.2	Applicative software	20
1.1.1.2.1	Mass air - flow variables	20
1.1.2	Acquisition of knock sensor input signal	22
1.1.2.1	Basic software	22
1.1.2.2	Applicative software	25
1.1.2.2.1	Knock signal amplification	25
1.1.2.2.2	Knock control window	27
1.1.2.2.3	Hysteresis function	28
1.1.2.2.4	Load range for knock control	29
1.1.2.2.5	Engine speed and load dynamics relative to knock control	31
1.1.2.2.6	Noise value	33
1.1.2.2.7	Knock detection threshold	35
1.1.2.2.8	Knock detection	37
1.1.3	Acquisition of after main relay battery voltage	38
1.1.4	Acquisition of after ignition key battery voltage	39
1.1.4.1	Ignition key ON / OFF recognition	40
1.1.4.2	Applicative software	41
1.1.4.3	Battery voltage	41
1.1.4.4	Ignition key detection	41
1.1.4.5	Battery over voltage detection	41
1.1.4.6	Low Battery voltage detection for OBD-I/-II Diagnosis	42
1.1.5	Acquisition of oxygen sensor voltage	43
1.1.5.1	Basic software	43
1.1.5.2	Applicative software	44
1.1.6	Acquisition of coolant temperature	45
1.1.6.1	Basic software	45
1.1.7	Acquisition of air intake temperature	46
1.1.7.1	Basic software	46
1.1.8	Acquisition of exhaust gas temperature	47
1.1.8.1	Basic software	47
1.2	Logic Inputs	48
1.2.1	Basic software	48
1.2.2	Applicative software	49
1.2.3	Acquisition of crankshaft signal	51
1.2.3.1	Basic software	51
1.2.3.1.1	Hardware configurable parameters	52
1.2.3.1.1.1	Active crankshaft edge definition	52
1.2.3.1.1.2	Minimum and maximum engine speed	52
1.2.3.1.2	Tooth time T_TOOTH calculation	53
1.2.3.1.3	Tooth gradient TOOTH_GRD calculation	53
1.2.3.1.4	Camshaft level shift register CAM_LEVEL_SHR	54
1.2.3.1.5	Tooth number function TOOTH_COUNTER	55
1.2.3.1.6	Engine running detection LV_RUN_ENG	56
1.2.3.1.7	Engine synchronisation detection LV_SYN_ENG	57

Proprietary data, company confidential. All rights reserved.
 Contient des informations confidentielles de la société. Tous droits réservés.
 Comunicado como secreto empresarial. Reservados todos los derechos.
 Confidado como secreto industrial. Nos reservamos todos los derechos.

Weitergabe sowie Vervielfältigung dieser Unterlage, Verwertung und Mitteilung ihres Inhalts ist gestattet, soweit nicht ausdrücklich zugestanden. Zuwiderhandlungen verpflichten zu Schadensersatz. Alle Rechte vorbehalten, insbesondere für den Fall der Patenterteilung oder GM-Entragung.

Editor:	Müller O.	17-Dec-97	Basic SW Inputs and Outputs	HMC_V6
Version:	a 153589 from 18.12.97		657765.49.02	
File:	CHAP_2.DOC	650H0000		Page 3 / 98

Proprietary data, company confidential. All rights reserved.
 Contient des informations confidentielles. Tous droits réservés.
 Comunicado como secreto empresarial. Reservados todos los derechos.
 Confidado como secreto industrial. Nos reservamos todos los derechos.

Weitergabe sowie Vervielfältigung dieser Unterlage, Verwertung und Mitteilung ihres Inhalts ist gestattet, soweit nicht ausdrücklich zugestanden. Zuwiderhandlungen verpflichten zu Schadensersatz. Alle Rechte vorbehalten, insbesondere für den Fall der Patenterteilung oder GM-Enttragung.

1.2.3.1.8	Engine stalling detection	58
1.2.3.1.9	Segment period measurement T_SEG	58
1.2.3.1.10	Low engine speed range determination LV_LOW_N	59
1.2.4	Acquisition of camshaft signal	62
1.2.4.1	Basic software	62
1.2.5	Acquisition of vehicle speed	65
1.2.5.1	Basic software	65
2	Actuation of Outputs	66
2.1	Logic Outputs	66
2.1.1	List of direct logic Outputs	66
2.1.2	List of logic Outputs via Octal Driver	67
2.2	PWM Outputs	68
2.2.1	Fuel injection output	71
2.2.1.1	Basic software	71
2.2.1.1.1	First injection time programming	72
2.2.1.1.2	Injection phase programming SOI (Start) and EOI (End)	76
2.2.1.1.3	Fuel shut-off	79
2.2.1.1.3.1	Fuel shut-off pattern INH_SWI_IV	79
2.2.1.1.3.2	Fuel shut-off with immediate re-activation versus L_INH_IV_[CYL] state	80
2.2.1.1.3.3	Fuel injection information	81
2.2.1.1.4	Injection time programming	81
2.2.1.1.5	Fuel injection under transient engine operation	82
2.2.2	Spark advance and Dwell output	84
2.2.2.1	Basic software	84
2.2.2.1.1	Normal ignition and Dwell control (LV_LOW_N = 0 (Passive))	84
2.2.2.1.2	Dwell control in case of low engine speed (LV_LOW_N = 1 (Active))	85
2.2.2.1.3	Dwell time "watchdog"	85
2.2.2.1.4	Multiple spark	86
2.2.2.2	Applicative software	87
2.2.2.2.1	Dwell time control	87
2.2.2.2.2	Multiple spark	88
2.2.3	Fuel consumption signal output FCO	90
2.2.3.1	Basic software	90
2.2.3.2	Applicative software	92
2.2.4	Engine speed signal output ESS	93
2.2.4.1	Basic software	93
2.2.5	Acquisition of primary over voltage duration V_DUR_IGC_[CYL]	94
2.2.6	Acquisition of throttle position	96
2.2.6.1	Basic software	96
2.2.6.2	Applicative software	97

Editor:	Müller O.	17-Dec-97	Basic SW Inputs and Outputs	HMC_V6
Version:	a 153589 from 18.12.97		657765.49.02	
File:	CHAP_2.DOC	650H0000		Page 4 / 98

Index	Page
* - Positive Logic	
use.....	48
3	
3 - 1	
use.....	48
3 - 14	
use.....	48
3 - 4	
use.....	48
3 - 5	
use.....	48
3 - 6	
use.....	48
3 - 7	
use.....	48
8	
8 - 6	
use.....	48
A	
AD_BUFFER	
def.....	16
use.....	18
C	
C_CRK_VLD_TOOTH	
def.....	60
C_FAC_TRA_KNK	
def.....	36
use.....	31
C_FCO_FAC	
def.....	92
C_IGA_LGRD_3	
def.....	30
C_IGA_MAF_HYS_KNK	
def.....	28
C_IGA_N_HYS_KNK	
def.....	28
C_IGC_DUR_N_MAX_DIAG	
use.....	94
C_NL_CRLC	
def.....	34
use.....	25
C_NL_CRLC_TRA	
def.....	34
C_NL_FAC_CRLC	
def.....	26
C_NL_FAC_LGRD	
def.....	26
C_NL_FAC_MMV_MAX	

Editor: Müller O.	17-Dec-97	Basic SW Inputs and Outputs	HMC_V6
Version: a 153589 from 18.12.97		657765.49.02	
File: CHAP_2.DOC	650H0000		Page 5 / 98

def.....	26
C_NL_FAC_MMV_MIN	
def.....	26
C_NL_MAX	
def.....	34
C_NL_MIN_DIAG	
def.....	34, 36
C_TCO_MAX_MPL	
def.....	89
C_TD_AS	
def.....	87
C_TD_T_MPL	
def.....	89
C_TPS_GRD_MAX	
def.....	98
C_TPS_HYS	
def.....	98
C_TPS_WOT_TPS_PWM	
def.....	70
C_VB_MIN_JUMP	
def.....	42
C_VB_MIN_OBD1	
def.....	42
C_VB_MIN_OBD2	
def.....	42
CAM_1_POS_TOOTH	
def.....	62
CAM_LEVEL_SHR	
def.....	51
use.....	62
CONF_NVMY_RST	
use.....	49
CONF_TCU	
use.....	49
CPPWM	
use.....	68
CRK_VALID_TEETH_CNT	
def.....	51
use.....	71
D	
DTP_BAS	
def.....	16
E	
EGRPWM	
use.....	68
EOI	
use.....	71
F	
FCO_SUM	
def.....	71
use.....	92
I	
ID_ADD_KNK__N_KNK	
def.....	36

Editor: Müller O.	17-Dec-97	Basic SW Inputs and Outputs	HMC_V6
Version: a 153589 from 18.12.97		657765.49.02	
File: CHAP_2.DOC	650H0000		Page 6 / 98

ID_FAC_KNK_[CYL]__N_KNK__MAF_KNK	
def.....	36
ID_FAC_TRA_CYCNR_KNK__N	
def.....	32
ID_KNKWB_[CYL]__N_KNK__MAF_KNK	
def.....	27
ID_KNKWE_[CYL]__N_KNK__MAF_KNK	
def.....	27
ID_MAF_TAB__V_MAF_1__V_MAF_2	
def.....	19
ID_N_GRD_MAX_KNK__N_KNK	
def.....	32
ID_TPS_GRD_TRA_KNK__N	
def.....	32
IGA_IGC_[CYL]	
use.....	84
INH_SWI_IV	
use.....	71
IP_MAF_MIN_KNK__N__TCO	
def.....	30
IP_NL_SP__N	
def.....	34
IP_NL_SP__N_32	
def.....	26
IP_TCO_TAB__V_TCO	
def.....	45
IP_TD__VB__N_32	
def.....	87
IP_TD_MPL__VB	
def.....	89
IP_TEG_TAB__V_TEG	
def.....	47
IP_TIA_TAB__V_TIA	
def.....	46
IP_V_KNK__N_32	
def.....	26
ISAPWM	
use.....	68
K	
KNK_INT_CYL_[CYL]	
def.....	37
KNKPWM	
def.....	25
use.....	68
KNKS_[CYL]	
def.....	22
use.....	33, 37
KNKWB_[CYL]	
def.....	27
use.....	22
KNKWE_[CYL]	
def.....	27
use.....	22
L	
L_IM_ACCIN	

Editor: Müller O.	17-Dec-97	Basic SW Inputs and Outputs	HMC_V6
Version: a 153589 from 18.12.97		657765.49.02	
File: CHAP_2.DOC	650H0000		Page 7 / 98

def.....	48
use.....	49
L_IM_SAV	
use.....	66
L_IM_VIC	
use.....	66
L_INH_IV_[CYL]	
use.....	71
L_KEY_OFF	
def.....	38, 39
use.....	41
L_MAF_ACC_CHOICE	
def.....	18
L_PIN_ACCIN	
use.....	48
L_PIN_ACIN	
use.....	48
L_PIN_EL_LOAD	
use.....	48
L_PIN_MIL_FLL_REQ	
use.....	48
L_PIN_PRS_ACC	
use.....	48
L_PIN_PVD	
use.....	48
L_PIN_VB_OFF	
use.....	48
L_PREV_STATE_IV_[CYL]	
def.....	71
Logic state	
use.....	48
LSH_DOWN_1_BAS	
def.....	16
LSH_DOWN_1PWM	
use.....	68
LSH_DOWN_2_BAS	
def.....	16
LSH_DOWN_2PWM	
use.....	68
LSH_UP_1PWM	
use.....	68
LSH_UP_2PWM	
use.....	68
LV_ACCIN	
def.....	49
LV_ACIN	
def.....	49
LV_CAM_1_EDGE	
def.....	62
LV_CAM_1_LVL	
def.....	62
LV_CDN_VB_OBD1	
def.....	41
LV_CDN_VB_OBD2	
def.....	41
LV_CRK_ERR_LIH	
use.....	62

Editor: Müller O.	17-Dec-97	Basic SW Inputs and Outputs	HMC_V6
Version: a 153589 from 18.12.97		657765.49.02	
File: CHAP_2.DOC	650H0000		Page 8 / 98

LV_CT	
use.....	68
LV_DRI	
def.....	49
LV_EL_LOAD	
def.....	49
LV_ES	
use.....	25, 29, 88
LV_GS	
def.....	49
LV_IGK	
def.....	41
LV_IM_ACIN	
def.....	48
use.....	49
LV_IM_DRI	
use.....	49
LV_IM_EL_LOAD	
def.....	48
use.....	49
LV_IM_GS	
use.....	49
LV_IM_MIL	
use.....	66
LV_IM_MIL_FLL_REQ	
def.....	48
LV_IM_PRS_ACC	
def.....	48
use.....	49
LV_IM_PVD	
def.....	48
LV_IM_PWL	
use.....	66
LV_IM_RLY_ACCOUT	
use.....	66
LV_IM_RLY_EFP	
use.....	66
LV_IM_RLY_FAN_H	
use.....	66
LV_IM_RLY_FAN_L	
use.....	66
LV_IM_RLY_MAIN	
use.....	66
LV_IM_RLY_SAP	
use.....	66
LV_IM_SOV	
use.....	66
LV_IM_VB_OFF	
def.....	48
use.....	49
LV_INH_TIPR	
def.....	71
LV_KNK	
def.....	35
LV_KNK_ACT	
def.....	29
use.....	25, 28, 37

Editor: Müller O.	17-Dec-97	Basic SW Inputs and Outputs	HMC_V6
Version: a 153589 from 18.12.97		657765.49.02	
File: CHAP_2.DOC	650H0000		Page 9 / 98

Proprietary data, company confidential. All rights reserved.
 Contient des données confidentielles de l'entreprise. Tous droits réservés.
 Comunicado como secreto empresarial. Reservados todos los derechos.
 Confiado como secreto industrial. Nos reservamos todos los derechos.

Weitergabe sowie Vervielfältigung dieser Unterlage, Verwertung und Mitteilung ihres Inhalts nicht gestattet, soweit nicht ausdrücklich zugestanden. Zuwiderhandlungen verpflichten zu Schadensersatz. Alle Rechte vorbehalten, insbesondere für den Fall der Patenterteilung oder GM-Enttragung.

LV_LOW_N	
def.....	51
use.....	71, 84
LV_MAF_ERR	
use.....	20, 29
LV_MPL_ADV_ACT	
def.....	88
use.....	84
LV_N_GRD_MAX_KNK	
def.....	31
LV_PRS_ACC	
def.....	49
LV_RUN_ENG	
def.....	51
use.....	71
LV_SET	
def.....	49
LV_ST	
use.....	25, 29, 88
LV_SYN_ENG	
def.....	51
use.....	62, 71
LV_TCO_ERR	
use.....	29
LV_TIPR_EOI_STOP	
use.....	71
LV_TIPR_SEQ	
use.....	71
LV_TPS_ERR	
use.....	68, 97
LV_TPS_GRD_TRA_KNK	
def.....	31
use.....	33, 35
LV_TPS_PLAUS_ERR	
use.....	68
LV_VB_JUMP	
def.....	41
use.....	88
LV_VB_OFF	
def.....	49
LV_VB_OFF_ACT	
def.....	49
M	
MAF	
use.....	28, 29
MAF_ACC	
def.....	18
use.....	20
MAF_ACC_SUM	
def.....	18
use.....	20
MAF_ACC1	
def.....	18
use.....	20
MAF_ACC1_SUM	
def.....	18

Editor: Müller O.	17-Dec-97	Basic SW Inputs and Outputs	HMC_V6
Version: a 153589 from 18.12.97		657765.49.02	
File: CHAP_2.DOC	650H0000		Page 10 / 98

use.....	20
MAF_BAS	
def.....	16
use.....	18
MAF_KGH	
def.....	20
MAF_KGH_MES	
def.....	20
MAF_KNK	
def.....	28
use.....	27, 35
MAF_MES	
def.....	20
MAF_SUB_DIAG	
use.....	20
N	
N	
use.....	20, 28, 29, 31, 33
N_32	
use.....	87, 88
N_GRD	
use.....	31
N_KNK	
def.....	28
use.....	27, 31, 35
Name	
use.....	48
NC_ACTIVE_CRK_EDGE	
def.....	60
NC_CAM_LEVEL_SHR_NO	
def.....	60
NC_CYL_NO	
def.....	24, 60
use.....	20, 25
NC_CYL_NO_TDC_REF_TOOTH_1	
def.....	24
NC_CYL_NO_TDC_REF_TOOTH_61	
def.....	24
NC_F_CPU	
def.....	60
NC_FAC_MAF_CYL	
def.....	21
use.....	20
NC_KEY_OFF_NR	
def.....	40
NC_KEY_OFF_THR	
def.....	40
NC_KEY_ON_NR	
def.....	40
NC_KNOCK_SAMPLE_RELOAD	
def.....	24
NC_KNOCK_SENSOR	
def.....	24
NC_LOW_N	
def.....	60
NC_MAX_EOI	

Editor: Müller O.	17-Dec-97	Basic SW Inputs and Outputs	HMC_V6
Version: a 153589 from 18.12.97		657765.49.02	
File: CHAP_2.DOC	650H0000		Page 11 / 98

use.....	71
NC_N_MAX	
def.....	60
NC_N_MIN	
def.....	60
NC_NR_TOOTH_GAP_TDC	
def.....	60
NC_T_CRK_STALL_FREQ	
def.....	60
NC_T1_FREQ	
def.....	60
NC_TOOTH_GRD_MAX	
def.....	60
NC_TOOTH_GRD_MAX_GAP	
def.....	60
NC_TOOTH_GRD_MIN	
def.....	60
NC_TOOTH_GRD_MIN_GAP	
def.....	60
NL_[CYL]	
def.....	33
use.....	25, 35
NL_FAC_MMV	
def.....	25
NL_THD_KNK	
def.....	35
NL_THD_KNK_[CYL]	
def.....	35
use.....	37
P	
Port - Channel	
use.....	48
Positive Logic	
use.....	48
S	
SOI	
use.....	71
SOI_TIPR	
use.....	71
SWI_GS	
use.....	49
T	
T_FCO	
def.....	92
use.....	90
T_SEG	
def.....	51
T_TOOTH	
def.....	51
use.....	84
TAR_GC	
use.....	49
TCO	
use.....	29, 88
TCO_BAS	

Editor: Müller O.	17-Dec-97	Basic SW Inputs and Outputs	HMC_V6
Version: a 153589 from 18.12.97		657765.49.02	
File: CHAP_2.DOC	650H0000		Page 12 / 98

Proprietary data, company confidential. All rights reserved.
 Contient des données confidentielles de l'entreprise. Tous droits réservés.
 Comunicado como secreto empresarial. Reservados todos os direitos.
 Confiado como secreto industrial. Nos reservamos todos los derechos.

Weitergabe sowie Vervielfältigung dieser Unterlage, Wertung und Mitteilung ihres Inhalts nicht gestattet, soweit nicht ausdrücklich zugestanden. Zuwiderhandlungen verpflichten zu Schadensersatz. Alle Rechte vorbehalten, insbesondere für den Fall der Patenterteilung oder GM-Eintragung

def.....	16
use.....	45
TCO_MES	
def.....	45
TD	
def.....	87
use.....	84
TD_MPL	
def.....	88
use.....	84
TD_MPL_DLY	
def.....	88
use.....	84
TEG_BAS	
use.....	47
TEG_MES	
def.....	47
TEGR_BAS	
def.....	16
TI_[CYL]	
def.....	71
TI_1	
use.....	71
TI_2	
use.....	71
TI_ADD_DLY	
use.....	71
TI_ADD_REAC_SCC_[CYL]	
use.....	71
TI_AS_[CYL]	
use.....	71
TI_CO_IS_BAS	
def.....	16
TI_SAM	
def.....	71
TIA_BAS	
def.....	16
use.....	46
TIA_MES	
def.....	46
TIPR	
use.....	71
TOOTH_COUNTER	
def.....	51
use.....	62
TOOTH_GRD	
def.....	51
TPS	
def.....	97
TPS_AD_MMV_IS	
use.....	97
TPS_BAS	
def.....	16
use.....	96
TPS_CAN	
def.....	97
TPS_GRD	

Editor: Müller O.	17-Dec-97	Basic SW Inputs and Outputs	HMC_V6
Version: a 153589 from 18.12.97		657765.49.02	
File: CHAP_2.DOC	650H0000		Page 13 / 98

use.....	31
TPS_MES	
def.....	96
TPS_MES_10	
def.....	96
TPS_MES_10_DIAG	
use.....	97
TPS_MES_DIAG	
use.....	97
V	
V_DUR_IGC_[CYL]	
def.....	94
V_IGK_BAS	
def.....	16
use.....	39
V_IGK_MES	
def.....	39
use.....	41
V_TCO	
def.....	45
V_TEG	
def.....	47
V_TIA	
def.....	46
VB	
def.....	41
use.....	87, 88
VB_BAS	
def.....	16
use.....	38
VB_MES	
def.....	38
use.....	41
VLS_1	
def.....	44
VLS_1_MES	
def.....	43
use.....	44
VLS_2	
def.....	44
VLS_2_MES	
def.....	43
use.....	44
VLS_CAT_1	
def.....	44
VLS_CAT_1_MES	
def.....	43
use.....	44
VLS_CAT_2	
def.....	44
VLS_CAT_2_MES	
def.....	43
use.....	44
VLS_DOWN_1_BAS	
def.....	16
use.....	43

Editor: Müller O.	17-Dec-97	Basic SW Inputs and Outputs	HMC_V6
Version: a 153589 from 18.12.97		657765.49.02	
File: CHAP_2.DOC	650H0000		Page 14 / 98

Proprietary data, company confidential. All rights reserved.
 Contine a titre de secret d'entreprise. Tous droits réservés.
 Comunicado como secreto empresarial. Reservados todos os direitos.
 Confidado como secreto industrial. Nos reservamos todos los derechos.

Weitergabe sowie Vervielfältigung dieser Unterlage, Verwertung und Mitteilung ihres Inhalts nicht gestattet, soweit nicht ausdrücklich zugestanden. Zuwiderhandlungen verpflichten zu Schadensersatz. Alle Rechte vorbehalten, insbesondere für den Fall der Patenterteilung oder GM-Entragung

VLS_DOWN_2_BAS	
def.....	16
use.....	43
VLS_UP_1_BAS	
def.....	16
use.....	43
VLS_UP_2_BAS	
def.....	16
use.....	43
VS_MES	
def.....	65

Editor: Müller O.	17-Dec-97	Basic SW Inputs and Outputs	HMC_V6
Version: a 153589 from 18.12.97		657765.49.02	
File: CHAP_2.DOC	650H0000		Page 15 / 98

1 Acquisition of Inputs

1.1 Analog Inputs

Output data:

Name	Mode	Hex. limits	Phys. limits	Resol.	Unit
AD_BUFFER	-				Volt
Table of raw acquisition values (16) for direct analog inputs.					
MAF_BAS	-	0...03FFH	0...4,9951	5 / 1024	Volt
Mass air flow sensor raw acquisition.					
V_IGK_BAS	-	0...03FFH	0...4,9951	5 / 1024	Volt
Battery voltage after Ignition key raw acquisition.					
VB_BAS	-	0...03FFH	0...4,9951	5 / 1024	Volt
Battery voltage after main relay raw acquisition.					
VLS_UP_1_BAS	-	0...03FFH	0...4,9951	5 / 1024	Volt
Upstream oxygen sensor voltage raw acquisition - Bank n° 1.					
VLS_UP_2_BAS	-	0...03FFH	0...4,9951	5 / 1024	Volt
Upstream oxygen sensor voltage raw acquisition - Bank n° 2.					
VLS_DOWN_1_BAS	-	0...03FFH	0...4,9951	5 / 1024	Volt
Downstream oxygen sensor voltage raw acquisition - Bank n° 1.					
VLS_DOWN_2_BAS	-	0...03FFH	0...4,9951	5 / 1024	Volt
Downstream oxygen sensor voltage raw acquisition - Bank n° 2.					
LSH_DOWN_1_BAS	-	0...03FFH	0...4,9951	5 / 1024	Volt
Current equivalent measurement for downstream oxygen sensor heater - Bank n° 1.					
LSH_DOWN_2_BAS	-	0...03FFH	0...4,9951	5 / 1024	Volt
Current equivalent measurement for downstream oxygen sensor heater - Bank n° 2.					
DTP_BAS	-	0...03FFH	0...4,9951	5 / 1024	Volt
Differential tank pressure sensor raw acquisition.					
TEGR_BAS	-	0...03FFH	0...4,9951	5 / 1024	Volt
EGR temperature sensor raw acquisition.					
TPS_BAS	-	0...03FFH	0...4,9951	5 / 1024	Volt
Throttle position sensor raw acquisition.					
TCO_BAS	-	0...03FFH	0...4,9951	5 / 1024	Volt
Coolant temperature sensor raw acquisition.					
TI_CO_IS_BAS	-	0...03FFH	0...4,9951	5 / 1024	Volt
Injection time correction for idle CO-adjustment					
TIA_BAS	-	0...03FFH	0...4,9951	5 / 1024	Volt
Intake air temperature sensor raw acquisition.					

Proprietary data, company confidential. All rights reserved.
 Contit a titre de secret d'entreprise. Tous droits réservés.
 Comunicado como segredo empresarial. Reservados todos os direitos.
 Confidado como secreto industrial. Nos reservamos todos los derechos.

Weitergabe sowie Vervielfältigung dieser Unterlage, Verwertung und Mitteilung ihres Inhalts nicht gestattet, soweit nicht ausdrücklich zugestanden. Zuwiderhandlungen verpflichten zu Schadenersatz. Alle Rechte vorbehalten, insbesondere für den Fall der Patenterteilung oder GM-Entragung.

Editor: Müller O.	17-Dec-97	Basic SW Inputs and Outputs	HMC_V6
Version: a 153589 from 18.12.97		657765.49.02	
File: CHAP_2.DOC	650H0000	Sourcefile:07200101.00G	Page 16 / 98

FUNCTION DESCRIPTION:

Direct analog inputs

Name	Acquisition rate (msec.)	Port - Channel	Remark	Application recurrence (msec.)
MAF	1	5 - 0	120 x N (rpm) / NC_CYL_NO	Segment
V_IGK	1	5 - 1		10
VLS_UP_1	5	5 - 2		10
VLS_UP_2	5	5 - 3		10
VLS_DOWN_1	5	5 - 4		20
VLS_DOWN_2	5	5 - 5		20
LSH_DOWN_1	1	5 - 6	Current O2 downstream sensor 1	To be defined
LSH_DOWN_2	1	5 - 7	Current O2 downstream sensor 2	To be defined
DTP	10	5 - 8		50 during monitoring 1 sec out of monitoring
TEGR	10	5 - 9		100
TPS	5	5 - 10		10
TCO	100	5 - 11		500
TI_CO_IS	100	5 - 12		100
VB	1	5 - 13		10
TIA	100	5 - 14		500
KNKS	0,3	5 - 15	During knock window .	

Proprietary data, company confidential. All rights reserved.
 Contient des données confidentielles de la société. Tous droits réservés.
 Comunicado como secreto empresarial. Reservados todos los derechos.
 Confidado como secreto industrial. Nos reservamos todos los derechos.

Weitergabe sowie Vervielfältigung dieser Unterlage, Wertung und Mitteilung ihres Inhalts nicht gestattet, soweit nicht ausdrücklich zugestanden. Zuwiderhandlungen verpflichten zu Schadensersatz. Alle Rechte vorbehalten, insbesondere für den Fall der Patenterteilung oder GM-Entragung.

Editor: Müller O.	17-Dec-97	Basic SW Inputs and Outputs	HMC_V6
Version: a 153589 from 18.12.97		657765.49.02	
File: CHAP_2.DOC	650H0000	Sourcefile:07200101.00G	Page 17 / 98

1.1.1 Acquisition of mass air - flow

1.1.1.1 Basic software

Output data:

Name	Mode	Hex. limits	Phys. limits	Resol.	Unit
MAF_ACC	-	0...FFFFFFFFH	0...6.7109E7	0.015625	kg/h
Accumulated mass air - flow measurements for segment number (2n), n = 1,2,3,...					
MAF_ACC1	-	0...FFFFFFFFH	0... 6.7109E7	0.015625	kg/h
Accumulated mass air - flow measurements for segment number (2n-1), n = 1,2,3,...					
MAF_ACC_SUM	-	0...FFFFH	0...65535	1	-
Counter for accumulated mass air - flow measurements for segment number (2n), n = 1,2,3,...					
MAF_ACC1_SUM	-	0...FFFFH	0...65535	1	-
Counter for accumulated mass air - flow measurements for segment number (2n-1), n = 1,2,3,...					
L_MAF_ACC_CHOICE	-	0...01H	0...1	1	-
Indicates if segment number is even or odd in order to choose MAF_ACC / MAF_ACC_SUM or MAF_ACC1 / MAF_ACC1_SUM.					

Input data:

AD_BUFFER	MAF_BAS		
-----------	---------	--	--

FUNCTION DESCRIPTION:

General information:

The raw value for mass air flow (MAF_BAS) is measured by continuous conversion (10 bits) every **1 msec**.

The raw values are converted by a table ID_MAF_TAB__V_MAF_1__V_MAF_2 into values with the unit **[kg/h]** and sum up in one of the two buffers, MAF_ACC and MAF_ACC1.

For this conversion, only (MAF_BAS / 4) is taken into account for set points (8 bits):

$$V_MAF_1 \leftarrow (MAF_BAS / 4) / 16$$

$$V_MAF_2 \leftarrow (MAF_BAS / 4) \text{ module } 16$$

The number of values is counted in MAF_ACC_SUM and MAF_ACC1_SUM.

A two-buffer-system is used to avoid incorrect mass air flow calculation. The buffers alternate with each change of segment, i.e. L_MAF_ACC_CHOICE is toggled each segment.

After having read out one buffer - MAF_ACC or MAF_ACC1 - the applicative software has to clear this buffer as well as the corresponding counter - MAF_ACC_SUM or MAF_ACC1_SUM

-.

Editor: Müller O.	17-Dec-97	Basic SW Inputs and Outputs	HMC_V6
Version: a 153589 from 18.12.97		657765.49.02	
File: CHAP_2.DOC	650H0000	Sourcefile:07200401.00A	Page 18 / 98

Proprietary data, company confidential. All rights reserved. Contiene a titre de secret d'entreprise. Tous droits réservés. Comunicado como segredo empresarial. Reservados todos os direitos. Confidado como secreto industrial. Nos reservamos todos los derechos.

Weitergabe sowie Vervielfältigung dieser Unterlage, Verwertung und Mitteilung ihres Inhalts nicht gestattet, soweit nicht ausdrücklich zugestanden. Zuwiderhandlungen verpflichten zu Schadenersatz. Alle Rechte vorbehalten, insbesondere für den Fall der Patenterteilung oder GM-Entragung.

Proprietary data, company confidential. All rights reserved. Contient des informations confidentielles. Tous droits réservés. Comunicado como secreto empresarial. Reservados todos los derechos. Confidado como secreto industrial. Nos reservamos todos los derechos.

Weitergabe sowie Vervielfältigung dieser Unterlage, Verbreitung und Mitteilung ihres Inhalts nicht gestattet, soweit nicht ausdrücklich zugestanden. Zuwiderhandlungen verpflichten zu Schadensersatz. Alle Rechte vorbehalten, insbesondere für den Fall der Patenterteilung oder GM-Entragung.

Initialisation :

After hardware reset, the buffers MAF_ACC and MAF_ACC1 and the corresponding counters MAF_ACC_SUM and MAF_ACC1_SUM have to be cleared and a pointer has to be initialised with the address of the linearization table ID_MAF_TAB__V_MAF_1__V_MAF_2.

Formula section:

Accumulated mass air flow calculation :

$$MAF_ACC = \sum_{i=1}^{i=MAF_ACC_SUM} MAF[i]$$

$$MAF_ACC1 = \sum_{i=1}^{i=MAF_ACC1_SUM} MAF[i]$$

with MAF[i] ← ID_MAF_TAB__V_MAF_1__V_MAF_2 (MAF_BAS / 4) : acquisition converted by the linearization table.

Remark: During updating of calibration files the linearization table ID_MAF_TAB__V_MAF_1__V_MAF_2 will not be updated.

Calibration data:

Name	Dim	Hex. limits	Phys. limits	Resol.	Unit
ID_MAF_TAB__V_MAF_1__V_MAF_2	16 x 16	0...FFFFH	0...65535 / 64	0.015625	kg/h
Conversion table for linearization of MAF value acquisition.					

Editor: Müller O.	17-Dec-97	Basic SW Inputs and Outputs	HMC_V6
Version: a 153589 from 18.12.97		657765.49.02	
File: CHAP_2.DOC	650H0000	Sourcefile:07200401.00A	Page 19 / 98

1.1.1.2 Applicative software

1.1.1.2.1 Mass air - flow variables

Output data:

Name	Mode	Hex. limits	Phys. limits	Resol.	Unit
MAF_KGH_MES	V	0...FFFFH	0...16383.75	0.25	kg/h
Mass air flow value calculated in kg/h.					
MAF_KGH	V	0...FFFFH	0...16383.75	0.25	kg/h
Mass air flow value in kg/h					
MAF_MES	V	0...FFFFH	0...1389	0.0212	mg/TDC
Mass air flow value measured in mg/TDC.					

Input data:

MAF_ACC	MAF_ACC1	MAF_ACC_SUM	MAF_ACC1_SUM
N	NC_FAC_MAF_CYL	NC_CYL_NO	MAF_SUB_DIAG
LV_MAF_ERR			

FUNCTION DESCRIPTION:

General information:

The buffers alternate with each change of segment. Also mass air flow per segment is calculated out of these average values.

Formula section:

- Calculation of MAF_KGH_MES in kg/h :

$$\mathbf{MAF_KGH_MES} = 1/16 * \mathbf{MAF_ACC} / \mathbf{MAF_ACC_SUM}$$

or

$$\mathbf{MAF_KGH_MES} = 1/16 * \mathbf{MAF_ACC1} / \mathbf{MAF_ACC1_SUM}$$

- Calculation of MAF_KGH in kg/h :

If LV_MAF_ERR = 0
then MAF_KGH = MAF_KGH_MES
else MAF_KGH = MAF_SUB_DIAG * N / NC_FAC_MAF_CYL

Remark : For further Information on MAF_SUB_DIAG refer to Chapter Diagnosis Management (Mass Air Flow Sensor Diagnosis)

- Calculation of MAF_MES in mg/TDC :

$$\mathbf{MAF_MES} = \mathbf{NC_FAC_MAF_CYL} * \mathbf{MAF_KGH} / \mathbf{N}$$

Remark : MAF_MES is used by various functions as the load signal.

Editor: Müller O.	17-Dec-97	Basic SW Inputs and Outputs	HMC_V6
Version: a 153589 from 18.12.97		657765.49.02	
File: CHAP_2.DOC	650H0000	Sourcefile:07200401.00A	Page 20 / 98

Calibration data:

Name	Dim	Hex. limits	Phys. limits	Resol.	Unit
NC_FAC_MAF_CYL	1	0...FFFFH	0...1.996	0.000030 4	-
Weighting factor for MAF_MES calculation function of the number of cylinder - Non adjustable calibration.					

Applicative Value : NC_FAC_MAF_CYL = **8000H** = 1 dec.

Proprietary data, company confidential. All rights reserved.
 Contine a titre de secret d'entreprise. Tous droits réservés.
 Comunicado como segredo empresarial. Reservados todos os direitos.
 Confidado como secreto industrial. Nos reservamos todos los derechos.

Weitergabe sowie Vervielfältigung dieser Unterlage, Verwertung und Mitteilung ihres Inhalts nicht gestattet, soweit nicht ausdrücklich zugestanden. Zuwiderhandlungen verpflichten zu Schadensersatz. Alle Rechte vorbehalten, insbesondere für den Fall der Patenterteilung oder GM-Eintragung

Editor: Müller O.	17-Dec-97	Basic SW Inputs and Outputs	HMC_V6
Version: a 153589 from 18.12.97		657765.49.02	
File: CHAP_2.DOC	650H0000	Sourcefile:07200401.00A	Page 21 / 98

1.1.2 Acquisition of knock sensor input signal

1.1.2.1 Basic software

Output data:

Name	Mode	Hex. limits	Phys. limits	Resol.	Unit
KNKS_[CYL]	V	0...FFH	0...4,9805	5 / 256	V.
Knock - noise for each cylinder.					

Input data:

KNKWB_[CYL]	KNKWE_[CYL]		
-------------	-------------	--	--

FUNCTION DESCRIPTION:

General information:

The knock sensor signal is measured with the SIEMENS - " Knock I.C. ".

It is possible to use one or two knock sensors.

Initialization :

By the synchronisation on the crankshaft signal the next knock - window has to be performed. Therefore two configuration bytes show the next segment :

- NC_CYL_NO_TDC_REF_TOOTH_1 : actual segment number of the first TDC after the tooth n° 1.
- NC_CYL_NO_TDC_REF_TOOTH_61 : actual segment number of the first TDC after the tooth n° 61.

System Description :

1 - Knock control window :

As the vibrations typical for knocking occur only at certain crankshaft angle positions, the values are measured precisely in these ranges.

Therefore each cylinder has its own input data for the *beginning* of the knock - window (**KNKWB_[CYL]**) and the *end* of the knock window (**KNKWE_[CYL]**). Within this range the knock noise is sampled every NC_KNOCK_SAMPLE_RELOAD µsec.

The control window is calculated in any engine operating condition and at any operating point.

At the end of the knock - window, the next knock - window (beginning and end) is performed.

Proprietary data, company confidential. All rights reserved. Contient des données confidentielles de la SIEMENS. Tous droits réservés. Comunicado como segredo empresarial. Reservados todos os direitos. Confidado como secreto industrial. Nos reservamos todos los derechos.

Weitergabe sowie Vervielfältigung dieser Unterlage, Verbreitung und Mitteilung ihres Inhalts nicht gestattet, soweit nicht ausdrücklich zugestanden. Zuwiderhandlungen verpflichten zu Schadenersatz. Alle Rechte vorbehalten, insbesondere für den Fall der Patenterteilung oder GM-Entragung.

Editor: Müller O.	17-Dec-97	Basic SW Inputs and Outputs	HMC_V6
Version: a 153589 from 18.12.97		657765.49.02	
File: CHAP_2.DOC	650H0000	Sourcefile:07200701.00A	Page 22 / 98

Proprietary data, company confidential. All rights reserved.
 Contine a titre de secret d'entreprise. Tous droits réservés.
 Comunicado como segredo empresarial. Reservados todos os direitos.
 Confidado como secreto industrial. Nos reservamos todos los derechos.

Weitergabe sowie Vervielfältigung dieser Unterlage, Verwertung und Mitteilung ihres Inhalts nicht gestattet, soweit nicht ausdrücklich zugestanden. Zuwiderhandlungen verpflichten zu Schadensersatz. Alle Rechte vorbehalten, insbesondere für den Fall der Patenterteilung oder GM-Entragung

2 - Selection of the knock sensor :

At the end of each knock - window the knock sensor for the next knock - window is selected.

The configuration byte NC_KNOCK_SENSOR shows the right knock sensor. For each segment, it is represented by a bit :

- 0 -> Knock sensor bank 1
- 1 -> Knock sensor bank 2

3 - Calculation of the knock - noise :

While the control - window is ON, the signal is subject to cyclic sampling by the knock sensor (every NC_KNOCK_SAMPLE_RELOAD μ s).

The three highest values derived from these measurements (Ka, Kb, Kc) are used for the knock - noise calculation.

For this purpose, the highest one of the 3 measured values (Ka) receives the highest weighting. At segment intervals, the knock value KNKS[CYL] is determined individually for each cylinder.

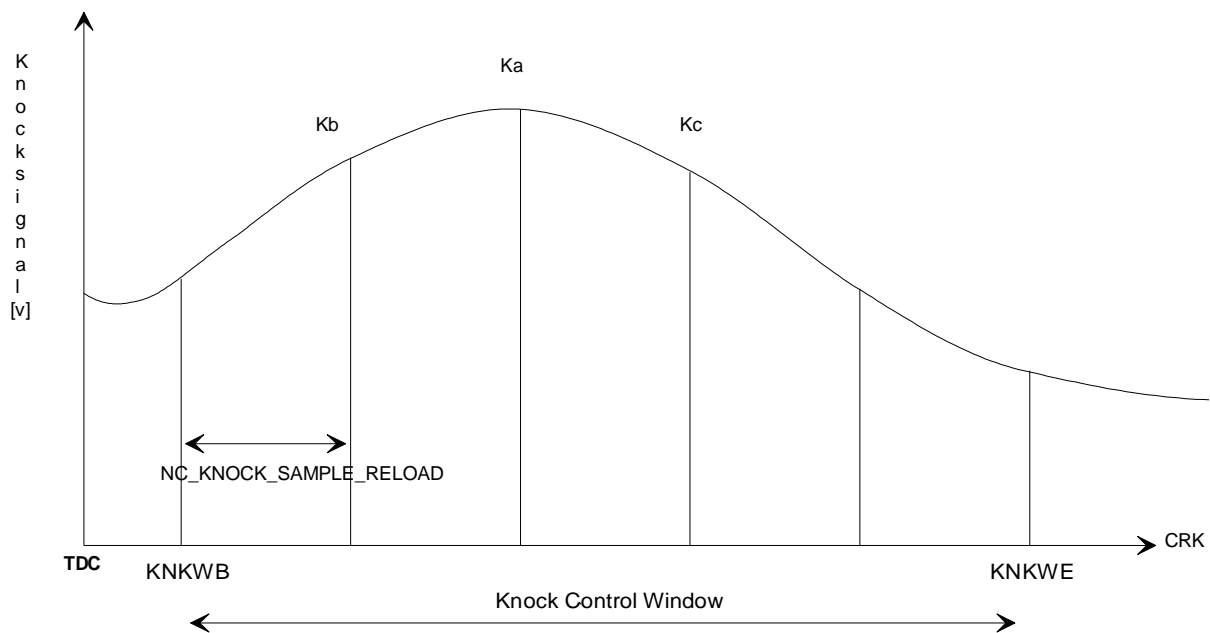

The knock value KNKS[CYL] is determined on the basis of the three highest values (Ka,Kb,Kc) according to the following algorithm :

- if the knock - control window is too “ small ” for sampling at least three values, then :
 - 1 sample : $KNKS_ [CYL] = Ka$
 - 2 samples : $KNKS_ [CYL] = (Ka + Kb)/2$
- if the knock - control window is sufficient for sampling at least three values, then :

$$KNKS_ [CYL] = [Ka + (Kb + Kc) / 2] / 2$$

Editor: Müller O.	17-Dec-97	Basic SW Inputs and Outputs	HMC_V6
Version: a 153589 from 18.12.97		657765.49.02	
File: CHAP_2.DOC	650H0000	Sourcefile:07200701.00A	Page 23 / 98

4 - Amplification of knock signal :

The knock sensor signal is controlled by a PWM signal.
 (Refer to the specification of “ PWM Outputs“)

Calibration data:

Name	Dim	Hex. limits	Phys. limits	Resol.	Unit
NC_KNOCK_SAMPLE_RELOAD	1	0001...FFFFH	0,004...262	4	msec
Sample period for knock sensor signal calculation - Non adjustable calibration.					
NC_KNOCK_SENSOR	1	00...FFH	0...255	1	-
Bit information for knock sensor number for each cylinder - Non adjustable calibration.					
NC_CYL_NO_TDC_REF_TOOTH_1	1	00...FFH	0...255	1	-
Segment number of the first TDC, after tooth n° 1. (NC_CYL_NO) - Non adjustable calibration.					
NC_CYL_NO_TDC_REF_TOOTH_61	1	00...FFH	0...255	1	-
Segment number of the first TDC, after tooth n° 61. (NC_CYL_NO) - Non adjustable calibration.					
NC_CYL_NO	1	00...FFH	0...255	1	-
Number of Cylinders - Non adjustable calibration.					

Applicative Values :

- NC_KNOCK_SAMPLE_RELOAD = **46H** = 75 dec. x 4 µsec = 300 µsec.
- NC_KNOCK_SENSOR = **2AH** = 00101010 bin.
- NC_CYL_NO_TDC_REF_TOOTH_1 = **01H** = 1 dec.
- NC_CYL_NO_TDC_REF_TOOTH_61 = **04H** = 4 dec.
- NC_CYL_NO = **06H** = 6 cylinders

Remark :

The applicative software is using the variables **KNKS_[CYL]** as the knock noise, and their values are corresponding to the **KNKS[CYL]** signal given by the basic software.

Proprietary data, company confidential. All rights reserved.
 Contit a titre de secret d'entreprise. Tous droits réservés.
 Comunicado como secreto empresarial. Reservados todos os direitos.
 Confidado como secreto industrial. Nos reservamos todos los derechos.

Weitergabe sowie Vervielfältigung dieser Unterlage, Verwertung und Mitteilung ihres Inhalts nicht gestattet, soweit nicht ausdrücklich zugestanden. Zuwiderhandlungen verpflichten zu Schadensersatz. Alle Rechte vorbehalten, insbesondere für den Fall der Patenterteilung oder GM-Entragung.

Editor: Müller O.	17-Dec-97	Basic SW Inputs and Outputs	HMC_V6
Version: a 153589 from 18.12.97		657765.49.02	
File: CHAP_2.DOC	650H0000	Sourcefile:07200701.00A	Page 24 / 98

1.1.2.2 Applicative software

1.1.2.2.1 Knock signal amplification

Output data:

Name	Mode	Hex. limits	Phys. limits	Resol.	Unit
KNKPWM	V	00...FFH	0...99,609	0,3891	%
Knock - noise amplified PWM send to basic software for generation of PWM output.					
NL_FAC_MMV	V	00...FFFFH	0...1,999	2 / 65536	-
Correction factor to calculate KNKPWM (the gain of the voltage - controlled amplifier for knock signal).					

Input data:

NL_[CYL]	C_NL_CRLC	NC_CYL_NO	LV_ES
LV_ST	LV_KNK_ACT		

FUNCTION DESCRIPTION:

General information:

A voltage - controlled amplifier is integrated into the input signal processing. The gain is controlled via a pulse - width modulated output signal of the processor.

The total gain consists of an open - loop control value IP_V_KNK__N_32 and a correction factor NL_FAC_MMV

It is calculated at intervals of 720 °CRK : $IP_V_KNK_N_32 * NL_FAC_MMV$

The result of the calculation above - mentioned is sent to the basic software (**KNKPWM**) for generation of the PWM Output.

Formula section:

- *Initialization :*

During engine operating states engine stopped LV_ES and start LV_ST, the correction factor NL_FAC_MMV is set to 1.

- *Calculation :*

For the purpose of the correction factor, the noise value derived from the mean value of each cylinders is compared to the target value IP_NL_SP__N and then :

If **LV_KNK_ACT = Active** since at least 1 segment
then $NL_FAC_MMV(n) = NL_FAC_MMV(n-1) + [1 - (\sum NL_x] / NC_CYL_NO) / IP_NL_SP_N_32] * C_NL_FAC_CRLC$

If **LV_KNK_ACT = Passive**
then $NL_FAC_MMV(n) = 1$ using gradient limitation $C_NL_FAC_LGRD * 720 \text{ °CRK}$

Editor: Müller O.	17-Dec-97	Basic SW Inputs and Outputs	HMC_V6
Version: a 153589 from 18.12.97		657765.49.02	
File: CHAP_2.DOC	650H0000	Sourcefile:07200701.00A	Page 25 / 98

The calibration data C_NL_FAC_CRLC is a filtering factor which serves to determine the control rate of the I - controller.

This filtering factor must be less than the filtering factor C_NL_CRLC used for generation of the noise value.

- *Limitation :*

$$C_NL_FAC_MMV_MIN \leq NL_FAC_MMV \leq C_NL_FAC_MMV_MAX$$

The final valid value for NL_FAC_MMV is not changed if the total gain reaches the maximum value (FFH).

- *Limp Home :*

If a diagnostic error is detected on one of the knock sensors, the correction factor NL_FAC_MMV is set to 1.

Calibration data:

Name	Dim	Hex. limits	Phys. limits	Resol.	Unit
C_NL_FAC_CRLC	1	0...FFH	0...0,1245	0,0005	-
Filtering factor for calculation of the correction factor used to calculate the voltage controller amplifier gain.					
C_NL_FAC_MMV_MIN	1	00...FFH	0...1,992	2 / 256	-
Minimum value for the correction factor of voltage controller amplifier gain.					
C_NL_FAC_MMV_MAX	1	00...FFH	0...1,992	2 / 256	-
Maximum value for the correction factor of the voltage controller amplifier gain.					
C_NL_FAC_LGRD	1	0...7FFFH	0...0,9999	1 / 32768	-
Gradient limitation for NL_FAC_MMV calculation when knock control is inactive.					
IP_NL_SP__N_32	8	0...FFH	0...4,9805	5 / 256	V.
Noise level threshold for knock signal amplification.					
IP_V_KNK__N_32	8	0...FFH	0...0,996	1 / 256	-
Gain of the voltage controlled amplifier versus engine speed for amplification of knock signal.					

Editor: Müller O.	17-Dec-97	Basic SW Inputs and Outputs	HMC_V6
Version: a 153589 from 18.12.97		657765.49.02	
File: CHAP_2.DOC	650H0000	Sourcefile:07200701.00A	Page 26 / 98

1.1.2.2.2 Knock control window

Output data:

Name	Mode	Hex. limits	Phys. limits	Resol.	Unit
KNKW _B _[CYL]	-	01...FFH	0,375...95,625	0,375	°CRK
Beginning of the control window for each cylinder (after TDC) send to the basic software.					
KNKW _E _[CYL]	-	0...FFH	12...107,625	0,375	°CRK
End of the control window for each cylinder send to the basic software.					

Input data:

MAF_KNK	N_KNK		
---------	-------	--	--

FUNCTION DESCRIPTION:

General information:

The control window is calculated in any engine operating condition and at any operating point. For the purpose of the adjustment, the control window must definitely be ≥ 1 msec.

Moreover, an interval of at least 1 msec. must be provided between the end of the current control window and the beginning of the following one, for the following cylinder.

Formula section:

- The start of the knock control window required for measurement of the knock signals is taken cylinder individually from one of the following tables:

$$ID_KNKW_B_[CYL]_N_KNK_MAF_KNK$$

- The end of the control window is taken cylinder individually from one of the following tables:

$$ID_KNKW_E_[CYL]_N_KNK_MAF_KNK$$

Calibration data:

Name	Dim	Hex. limits	Phys. limits	Resol.	Unit
ID_KNKW _B _[CYL]_N_KNK_MAF_KNK	16 x 4	01...FFH	0,375...95,625	0,375	°CRK
The tables for beginning of control window to the cylinders and knock sensors.					
ID_KNKW _E _[CYL]_N_KNK_MAF_KNK	16 x 4	0...FFH	12...107,625	0,375	°CRK
The tables for end of the control window to cylinders and knock sensors.					

Proprietary data, company confidential. All rights reserved. Contitue a titre de secret d'entreprise. Tous droits réservés. Comunicado como segredo empresarial. Reservados todos os direitos. Confidado como secreto industrial. Nos reservamos todos los derechos.

Weitergabe sowie Vervielfältigung dieser Unterlage, Verwertung und Mitteilung ihres Inhalts nicht gestattet, soweit nicht ausdrücklich zugestanden. Zuwiderhandlungen verpflichten zu Schadenersatz. Alle Rechte vorbehalten, insbesondere für den Fall der Patenterteilung oder GM-Entragung.

Editor: Müller O.	17-Dec-97	Basic SW Inputs and Outputs	HMC_V6
Version: a 153589 from 18.12.97		657765.49.02	
File: CHAP_2.DOC	650H0000	Sourcefile:07200701.00A	Page 27 / 98

1.1.2.2.3 Hysteresis function

Output data:

Name	Mode	Hex. limits	Phys. limits	Resol.	Unit
N_KNK	V	0...FFH	0...8160	32	rpm
Specific engine speed for knock control active.					
MAF_KNK	V	0...FFH	0...1389	5,45	mg/TDC
Specific mass air flow for knock control active.					

Input data:

MAF	N	LV_KNK_ACT	
-----	---	------------	--

FUNCTION DESCRIPTION:

General information:

A hysteresis function is applied on engine speed and mass air flow for all tables and maps within the knock control active (LV_KNK_ACT = Active). It is used in order to avoid some jumps in the case of small engine speed and mass air flow changes.

Application conditions:

LV_KNK_ACT = Active

Formula section:

If $|N_KNK - N_{actual}| > C_IGA_N_HYS_KNK$

then $N_KNK = N_{actual}$

else N_KNK remains unchanged.

If $|MAF_KNK - MAF_{actual}| > C_IGA_MAF_HYS_KNK$

then $MAF_KNK = MAF_{actual}$

else MAF_KNK remains unchanged.

Calibration data:

Name	Dim	Hex. limits	Phys. limits	Resol.	Unit
C_IGA_N_HYS_KNK	1	0...FFH	0...8160	32	rpm
Engine speed hysteresis for knock control active.					
C_IGA_MAF_HYS_KNK	1	0...FFH	0...1389	5,45	mg/TDC
Mass air flow hysteresis for knock control active.					

Editor: Müller O.	17-Dec-97	Basic SW Inputs and Outputs	HMC_V6
Version: a 153589 from 18.12.97		657765.49.02	
File: CHAP_2.DOC	650H0000	Sourcefile:07200701.00A	Page 28 / 98

Proprietary data, company confidential. All rights reserved. Contine a titre de secret d'entreprise. Tous droits réservés. Comunicado como segredo empresarial. Reservados todos os direitos. Confidado como secreto industrial. Nos reservamos todos los derechos.

Weitergabe sowie Vervielfältigung dieser Unterlage, Verwertung und Mitteilung ihres Inhalts nicht gestattet, soweit nicht ausdrücklich zugestanden. Zuwiderhandlungen verpflichten zu Schadenersatz. Alle Rechte vorbehalten, insbesondere für den Fall der Patenterteilung oder GM-Enttragung.

1.1.2.2.4 Load range for knock control

Output data:

Name	Mode	Hex. limits	Phys. limits	Resol.	Unit
LV_KNK_ACT	V	0...01H	0...1	1	-
Boolean for knock control active.					

Input data:

MAF	N	TCO	LV_ST
LV_TCO_ERR	LV_MAF_ERR	LV_ES	

FUNCTION DESCRIPTION:

General information:

The load range in which the knock control is active is defined by an engine speed and coolant temperature dependent characteristic.

If the actual mass air flow is below a threshold, only the noise value will be generated and the ignition angle correction IGA_KNK_[CYL] is reset using change limitation C_IGA_LGRD_3 (refer to chapter „Diagnosis“) and will be controlled back.

Application conditions:

Initialization :

LV_KNK_ACT= Passive

Activation:

If MAF >= IP_MAF_MIN_KNK__N__TCO
and LV_ES= 0 (no engine operating state “ Engine Stopped “)
and LV_ST= 0 (no engine operating state “Start “)
then LV_KNK_ACT = Active

Deactivation:

If MAF < IP_MAF_MIN_KNK__N__TCO
or LV_ES = 1 (engine operating state “ Engine Stopped “)
or LV_ST = 1 (engine operating state “Start “)
or Key OFF
then LV_KNK_ACT = Passive

Limp Home :

In case of diagnostic error on coolant temperature (LV_TCO_ERR) or mass air flow meter (LV_MAF_ERR) the corresponding limp home values will be used.
 (Refer to chapter : “ Diagnosis Management “)

Editor: Müller O.	17-Dec-97	Basic SW Inputs and Outputs	HMC_V6
Version: a 153589 from 18.12.97		657765.49.02	
File: CHAP_2.DOC	650H0000	Sourcefile:07200701.00A	Page 29 / 98

Calibration data:

Name	Dim	Hex. limits	Phys. limits	Resol.	Unit
C_IGA_LGRD_3	1	01...7FFFH	0,0015...47,9985	0,0015	°CRK
Ignition angle limitation gradient for area 3 (x 120 °CRK)					
IP_MAF_MIN_KNK__N__TCO	8 x 4	0...FFH	0...1389	5,45	mg/TDC
Mass air flow threshold for activation of knock control.					

Proprietary data, company confidential. All rights reserved.
 Contine a titre de secret d'entreprise. Tous droits réservés.
 Comunicado como segredo empresarial. Reservados todos os direitos.
 Confidado como secreto industrial. Nos reservamos todos los derechos.

Weitergabe sowie Vervielfältigung dieser Unterlage, Verwertung und Mitteilung ihres Inhalts nicht gestattet, soweit nicht ausdrücklich zugestanden. Zuwiderhandlungen verpflichten zu Schadensersatz. Alle Rechte vorbehalten, insbesondere für den Fall der Patenterteilung oder GM-Eintragung.

Editor: Müller O.	17-Dec-97	Basic SW Inputs and Outputs	HMC_V6
Version: a 153589 from 18.12.97		657765.49.02	
File: CHAP_2.DOC	650H0000	Sourcefile:07200701.00A	Page 30 / 98

1.1.2.2.5 Engine speed and load dynamics relative to knock control

Output data:

Name	Mode	Hex. limits	Phys. limits	Resol.	Unit
LV_N_GRD_MAX_KNK	V	0..01H	0..1	1	-
Boolean for engine speed dynamics relative to knock control.					
LV_TPS_GRD_TRA_KNK	V	0..01H	0..1	1	-
Boolean for load dynamics relative to knock control.					

Input data:

TPS_GRD	N	N_KNK	N_GRD
C_FAC_TRA_KNK			

FUNCTION DESCRIPTION:

General information:

To allow a fast follow-up of the knock - noise values in case of a fast changing engine speed or engine load, some conditions for dynamics detection are defined.

Application conditions:

Available for all engine operating states.

- *Initialization :*

$$LV_N_GRD_MAX_KNK = 0$$

$$LV_TPS_GRD_TRA_KNK = 0$$

- *Activation:*

a - Engine speed dynamics :

If | N_GRD | >= ID_N_GRD_MAX_KNK__N_KNK
then LV_N_GRD_MAX_KNK = 1

Moreover, when LV_N_GRD_MAX_KNK = 1, the values of the knock adaptation are only read.

b - Load dynamics :

If TPS_GRD >= ID_TPS_GRD_TRA_KNK__N
then LV_TPS_GRD_TRA_KNK = 1 during
 ID_FAC_TRA_CYCNR_KNK__N cycles.

Moreover, when LV_TPS_GRD_TRA_KNK = 1, the knock detection sensitivity is reduced with the weighting factor C_FAC_TRA_KNK and the values of the knock adaptation are only read.

Editor: Müller O.	17-Dec-97	Basic SW Inputs and Outputs	HMC_V6
Version: a 153589 from 18.12.97		657765.49.02	
File: CHAP_2.DOC	650H0000	Sourcefile:07200701.00A	Page 31 / 98

Proprietary data, company confidential. All rights reserved. Contine a titre de secret d'entreprise. Tous droits réservés. Comunicado como segredo empresarial. Reservados todos os direitos. Confidado como secreto industrial. Nos reservamos todos los derechos.

Weitergabe sowie Vervielfältigung dieser Unterlage, Verwertung und Mitteilung ihres Inhalts nicht gestattet, soweit nicht ausdrücklich zugestanden. Zuwiderhandlungen verpflichten zu Schadensersatz. Alle Rechte vorbehalten, insbesondere für den Fall der Patenterteilung oder GM-Entragung.

Deactivation:

a - Engine speed dynamics :

If | N_GRD | < ID_N_GRD_MAX_KNK__N_KNK

then LV_N_GRD_MAX_KNK = 0

b - Load dynamics :

If TPS_GRD < ID_TPS_GRD_TRA_KNK__N

or the active period ID_FAC_TRA_CYCNR_KNK__N has run out

then LV_TPS_GRD_TRA_KNK = 0

Calibration data:

Name	Dim	Hex. limits	Phys. limits	Resol.	Unit
ID_N_GRD_MAX_KNK__N_KNK	16	0...7FH	0...4064	32	rpm/sec
N_GRD threshold to detect engine speed dynamic relative to knock control.					
ID_TPS_GRD_TRA_KNK__N	4	0...FFH	0...2988	11,72	°TPS/sec
TPS_GRD threshold to detect engine load dynamic relative to knock control.					
ID_FAC_TRA_CYCNR_KNK__N	4	0...FFH	0...255	1	-
Duration of the engine load dynamic detected (x 120 °CRK)					

Proprietary data, company confidential. All rights reserved.
 Contine a titre de secret d'entreprise. Tous droits réservés.
 Comunicado como segredo empresarial. Reservados todos os direitos.
 Confidado como secreto industrial. Nos reservamos todos los derechos.

Weitergabe sowie Vervielfältigung dieser Unterlage, Verbreitung und Mitteilung ihres Inhalts nicht gestattet, soweit nicht ausdrücklich zugestanden. Zuwiderhandlungen verpflichten zu Schadensersatz. Alle Rechte vorbehalten, insbesondere für den Fall der Patenterteilung oder GM-Entragung.

Editor: Müller O.	17-Dec-97	Basic SW Inputs and Outputs	HMC_V6
Version: a 153589 from 18.12.97		657765.49.02	
File: CHAP_2.DOC	650H0000	Sourcefile:07200701.00A	Page 32 / 98

1.1.2.2.6 Noise value

Output data:

Name	Mode	Hex. limits	Phys. limits	Resol.	Unit
NL_[CYL]	V	0...FFFFH	0...4,9999	5 / 65536	V.
Noise value of cylinder i.					

Input data:

KNKS_[CYL]	N	LV_TPS_GRD_TRA_KNK
------------	---	--------------------

FUNCTION DESCRIPTION:

General information:

The noise value NL_[CYL] is calculated individually for each cylinder. It is a floating mean - value of the knock value KNKS[CYL]. Two different filter constants are used depending on steady state or transients.

Application conditions:

NL_[CYL] calculation is made in all engine operating states.

Initialization :

$$NL_ [CYL] = IP_ NL_ SP_ N$$

Formula section:

Calculation :

If LV_TPS_GRD_TRA_KNK = 0 (engine load dynamic not active)
then NL_[CYL] = NL_[CYL] + (KNKS_[CYL] - NL_[CYL]) * C_NL_CRLC

If LV_TPS_GRD_TRA_KNK = 1 (engine load dynamic active)
then NL_[CYL] = NL_[CYL] + (KNKS_[CYL] - NL_[CYL]) * C_NL_CRLC_TRA

Limitation :

- Maximum limit :

The noise value NL_[CYL] is limited to C_NL_MAX.

- Minimum limit :

If all the noise values relative to a knock sensor are below a threshold C_NL_MIN_DIAG then a diagnostic error is detected. For the emergency operation, refer to chapter "Diagnosis Management".

Proprietary data, company confidential. All rights reserved. Contient a titre de secret d'entreprise. Tous droits réservés. Comunicado como segredo empresarial. Reservados todos os direitos. Confidado como secreto industrial. Nos reservamos todos los derechos.

Weitergabe sowie Vervielfältigung dieser Unterlage, Wertung und Mitteilung ihres Inhalts nicht gestattet, soweit nicht ausdrücklich zugestanden. Zuwiderhandlungen verpflichten zu Schadensersatz. Alle Rechte vorbehalten, insbesondere für den Fall der Patenterteilung oder GM-Entragung.

Editor: Müller O.	17-Dec-97	Basic SW Inputs and Outputs	HMC_V6
Version: a 153589 from 18.12.97		657765.49.02	
File: CHAP_2.DOC	650H0000	Sourcefile:07200701.00A	Page 33 / 98

Calibration data:

Name	Dim	Hex. limits	Phys. limits	Resol.	Unit
C_NL_CRLC	1	01...FFH	0,004...0,9961	1 / 256	-
Knock - noise filtering factor in steady state.					
C_NL_CRLC_TRA	1	01...FFH	0,004...0,9961	1 / 256	-
Knock - noise filtering factor with engine speed and / or engine load dynamics active.					
IP_NL_SP__N	8	0...FFH	0...4,9805	5 / 256	V.
Knock - noise level threshold for knock signal amplification.					
C_NL_MIN_DIAG	1	0...FFH	0...4,9805	5 / 256	V.
Knock - noise level threshold for knock acquisition diagnostic error detection.					
C_NL_MAX	1	0...FFH	0...4,9805	5 / 256	V.
Maximum knock - noise level limitation.					

Proprietary data, company confidential. All rights reserved.
 Contitue a titre de secret d'entreprise. Tous droits réservés.
 Comunicado como segredo empresarial. Reservados todos os direitos.
 Confidado como secreto industrial. Nos reservamos todos los derechos.

Weitergabe sowie Vervielfältigung dieser Unterlage, Verwertung und Mitteilung ihres Inhalts nicht gestattet, soweit nicht ausdrücklich zugestanden. Zuwiderhandlungen verpflichten zu Schadensersatz. Alle Rechte vorbehalten, insbesondere für den Fall der Patenterteilung oder GM-Eintragung

Editor: Müller O.	17-Dec-97	Basic SW Inputs and Outputs	HMC_V6
Version: a 153589 from 18.12.97		657765.49.02	
File: CHAP_2.DOC	650H0000	Sourcefile:07200701.00A	Page 34 / 98

1.1.2.2.7 Knock detection threshold

Output data:

Name	Mode	Hex. limits	Phys. limits	Resol.	Unit
LV_KNK	V	0...01H	0...1	1	-
Boolean for knock detected above the knock - noise threshold. (- / KNK)					
NL_THD_KNK	V	0...FFH	0...4,9805	5 / 256	V
Noise level threshold for knock detection updated each segment.					
NL_THD_KNK_[CYL]	V	0...FFH	0...4,9805	5 / 256	V
Noise level threshold for knock detection updated each crankshaft revolution.					

Input data:

NL_[CYL]	N_KNK	MAF_KNK	LV_TPS_GRD_TRA_KNK
----------	-------	---------	--------------------

FUNCTION DESCRIPTION:

General information:

The knock thresholds NL_THD_KNK_[CYL] are the limits for the knock values and are used for the knock control decision. They are calculated individually for each cylinder depending on the noise value and conditions for dynamics.

In case of engine load dynamics, a weighting factor C_FAC_TRA_KNK is used to calculate the absolute knock threshold.

Formula section:

Calculation :

1 - If NL_[CYL] < C_NL_MIN_DIAG (absolute threshold) **then**

a - Engine load dynamics not active :

(LV_TPS_GRD_TRA_KNK = 0)

The noise level threshold NL_THD_KNK_[CYL] is calculated as following :

$(C_NL_MIN_DIAG + ID_ADD_KNK_N_KNK) * ID_FAC_KNK_CYL_N_KNK_MAF_KNK$

b - Engine load dynamics active :

(LV_TPS_GRD_TRA_KNK = 1)

The noise level threshold NL_THD_KNK_[CYL] is calculated as following :

$(C_NL_MIN_DIAG + ID_ADD_KNK_N_KNK) * ID_FAC_KNK_CYL_N_KNK_MAF_KNK * C_FAC_TRA_KNK$

Proprietary data, company confidential. All rights reserved. Contine a titre de secret d'entreprise. Tous droits réservés. Comunicado como segredo empresarial. Reservados todos os direitos. Confidado como secreto industrial. Nos reservamos todos los derechos.

Weitergabe sowie Vervielfältigung dieser Unterlage, Verwertung und Mitteilung ihres Inhalts ist gestattet, soweit nicht ausdrücklich zugestanden. Zuwiderhandlungen verpflichten zu Schadensersatz. Alle Rechte vorbehalten, insbesondere für den Fall der Patenterteilung oder GM-Entragung.

Editor: Müller O.	17-Dec-97	Basic SW Inputs and Outputs	HMC_V6
Version: a 153589 from 18.12.97		657765.49.02	
File: CHAP_2.DOC	650H0000	Sourcefile:07200701.00A	Page 35 / 98

Proprietary data, company confidential. All rights reserved. Contine a titre de secret d'entreprise. Tous droits réservés. Comunicado como segredo empresarial. Reservados todos os direitos. Confidado como secreto industrial. Nos reservamos todos los derechos.

Weitergabe sowie Vervielfältigung dieser Unterlage, Verwertung und Mitteilung ihres Inhalts nicht gestattet, soweit nicht ausdrücklich zugestanden. Zuwiderhandlungen verpflichten zu Schadenersatz. Alle Rechte vorbehalten, insbesondere für den Fall der Patenterteilung oder GM-Entragung.

- 2 - If $NL_{[CYL]} \geq C_NL_MIN_DIAG$ (relative threshold) then
- a - *Engine load dynamics not active :*
 $(LV_TPS_GRD_TRA_KNK = 0)$
 The noise level threshold $NL_THD_KNK_{[CYL]}$ is calculated as following :
 $(NL_{[CYL]} + ID_ADD_KNK_N_KNK) * ID_FAC_KNK_{[CYL]}_N_KNK_MAF_KNK$
 - b - *Engine load dynamics active :*
 $(LV_TPS_GRD_TRA_KNK = 1)$
 The noise level threshold $NL_THD_KNK_{[CYL]}$ is calculated as following :
 $(NL_{[CYL]} + ID_ADD_KNK_N_KNK) * ID_FAC_KNK_{[CYL]}_N_KNK_MAF_KNK$
 $* C_FAC_TRA_KNK$

Remark :

The additive correction $ID_ADD_KNK_N_KNK$ is used to shift the knock threshold in the positive or negative direction, depending on the engine speed.

Calibration data:

Name	Dim	Hex. limits	Phys. limits	Resol.	Unit
C_FAC_TRA_KNK	1	20...FFH	1...7,968	0,0313	-
Correction factor for knock detection threshold calculation with engine speed and / or engine load dynamics active.					
ID_FAC_KNK_[CYL]__N_KNK__MAF_KNK	16 x 4	0...FFH	0...7,968	0,0313	-
Multiplicative factor for knock detection threshold calculation for each cylinder.					
ID_ADD_KNK__N_KNK	16	80...7FH	-2,5...2,48	5 / 256	V.
Additive factor for knock detection threshold calculation.					
C_NL_MIN_DIAG	1	0...FFH	0...4,9805	5 / 256	V.
Knock - noise level threshold for knock acquisition diagnostic error detection.					

Editor: Müller O.	17-Dec-97	Basic SW Inputs and Outputs	HMC_V6
Version: a 153589 from 18.12.97		657765.49.02	
File: CHAP_2.DOC	650H0000	Sourcefile:07200701.00A	Page 36 / 98

1.1.2.2.8 Knock detection

Output data:

Name	Mode	Hex. limits	Phys. limits	Resol.	Unit
KNK_INT_CYL_[CYL]	V	0..02H	0..2	1	-
Knock intensity detected for the corresponding cylinder (No, Intensity 1, Intensity 2).					

Input data:

KNKS_[CYL]	LV_KNK_ACT	NL_THD_KNK_[CYL]	
------------	------------	------------------	--

FUNCTION DESCRIPTION:

General information:

If the knock value KNKS_[CYL] is greater or equal to the knock detection threshold NL_THD_KNK_[CYL] and engine load above a threshold (LV_KNK_ACT = Active), then knock is detected on the corresponding cylinder.

According to KNKS_[CYL] value, two knock intensities are distinguished.

Formula section:

If $KNKS_ [CYL] < NL_ THD_ KNK_ [CYL]$
then $KNK_ INT_ CYL_ [CYL] = 0$ **(No)**

If $NL_ THD_ KNK_ [CYL] \leq KNKS_ [CYL] < 2 * NL_ THD_ KNK_ [CYL]$
then $KNK_ INT_ CYL_ [CYL] = 1$ **(Intensity 1)**

If $KNKS_ [CYL] \geq 2 * NL_ THD_ KNK_ [CYL]$
then $KNK_ INT_ CYL_ [CYL] = 2$ **(Intensity 2)**

Proprietary data, company confidential. All rights reserved.
 Contient a titre de secret d'entreprise. Tous droits réservés.
 Comunicado como segredo empresarial. Reservados todos os direitos.
 Confidado como secreto industrial. Nos reservamos todos los derechos.

Weitergabe sowie Vervielfältigung dieser Unterlage, Verwertung und Mitteilung ihres Inhalts nicht gestattet, soweit nicht ausdrücklich zugestanden. Zuwiderhandlungen verpflichten zu Schadenersatz. Alle Rechte vorbehalten, insbesondere für den Fall der Patenterteilung oder GM-Entragung.

Editor: Müller O.	17-Dec-97	Basic SW Inputs and Outputs	HMC_V6
Version: a 153589 from 18.12.97		657765.49.02	
File: CHAP_2.DOC	650H0000	Sourcefile:07200701.00A	Page 37 / 98

1.1.3 Acquisition of after main relay battery voltage

Output data:

Name	Type	V/S	Hex. limits	Phys. limits	Resol.	Unit
VB_MES	2U	-	0...03FFH	0...25,9746	26 / 1024	Volt
Battery voltage value measured (10 bits).						
L_KEY_OFF	Bool	-	0...01H	0...1	1	-
Boolean for ignition key status (ON / OFF).						

Input data:

VB_BAS			
--------	--	--	--

FUNCTION DESCRIPTION:

General information:

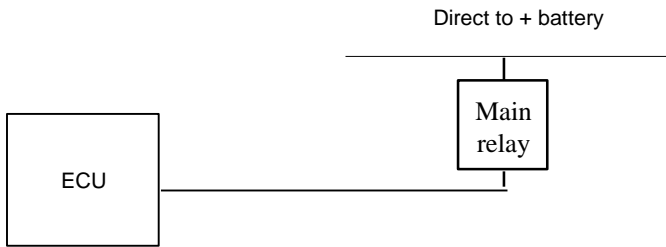

The analog input signal for ignition key ON / OFF detection is used for battery voltage acquisition and the battery voltage acquisition is used to elaborate corrections, to drive actuators and enable to secure diagnosis.

The raw value for battery voltage (VB_BAS) is measured by continuous conversion (10 bits) every 1 msec.

Formula section:

The application recurrence is **10 msec**.

$$VB_MES = 1 / 8 * \sum_{n=1}^{n=8} VB_BAS_n$$

Proprietary data, company confidential. All rights reserved. Contine a titre de secret d'entreprise. Tous droits réservés. Comunicado como segredo empresarial. Reservados todos os direitos. Confidado como secreto industrial. Nos reservamos todos los derechos.

Weitergabe sowie Vervielfältigung dieser Unterlage, Verwertung und Mitteilung ihres Inhalts nicht gestattet, soweit nicht ausdrücklich zugestanden. Zuwiderhandlungen verpflichten zu Schadensersatz. Alle Rechte vorbehalten, insbesondere für den Fall der Patenterteilung oder GM-Entragung.

Editor: Müller O.	17-Dec-97	Basic SW Inputs and Outputs	HMC_V6
Version: a 153589 from 18.12.97		657765.49.02	
File: CHAP_2.DOC	650H0000	Sourcefile:07200801.00B	Page 38 / 98

1.1.4 Acquisition of after ignition key battery voltage

Proprietary data, company confidential. All rights reserved. Contine a titre de secret d'entreprise. Tous droits réservés. Comunicado como segredo empresarial. Reservados todos os direitos. Confidado como secreto industrial. Nos reservamos todos los derechos.

Weitergabe sowie Vervielfältigung dieser Unterlage, Wertung und Mitteilung ihres Inhalts nicht gestattet, soweit nicht ausdrücklich zugestanden. Zuwiderhandlungen verpflichten zu Schadensersatz. Alle Rechte vorbehalten, insbesondere für den Fall der Patenterteilung oder GM-Entragung.

Output data:

Name	Type	V/S	Hex. limits	Phys. limits	Resol.	Unit
V_IGK_MES	2U	-	0...03FFH	0...25,9746	26 / 1024	Volt
Battery voltage value measured (10 bits).						
L_KEY_OFF	Bool	-	0...01H	0...1	1	-
Boolean for ignition key status (ON / OFF).						

Input data:

V_IGK_BAS			
-----------	--	--	--

FUNCTION DESCRIPTION:

General information:

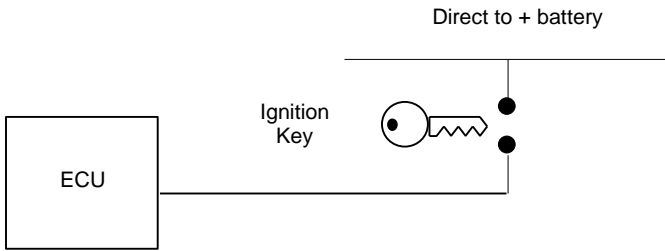

The battery voltage acquisition is used to elaborate corrections, to drive actuators and enable to secure diagnosis.
 The raw value for battery voltage (V_IGK_BAS) is measured by continuous conversion (10 bits) every 1 msec.

Formula section:

The application recurrence is **10 msec**.

$$V_IGK_MES = \frac{1}{8} * \sum_{n=1}^{n=8} V_IGK_BAS_n$$

Editor: Müller O.	17-Dec-97	Basic SW Inputs and Outputs	HMC_V6
Version: a 153589 from 18.12.97		657765.49.02	
File: CHAP_2.DOC	650H0000	Sourcefile:07200901.00A	Page 39 / 98

1.1.4.1 Ignition key ON / OFF recognition

FUNCTION DESCRIPTION:

General information:

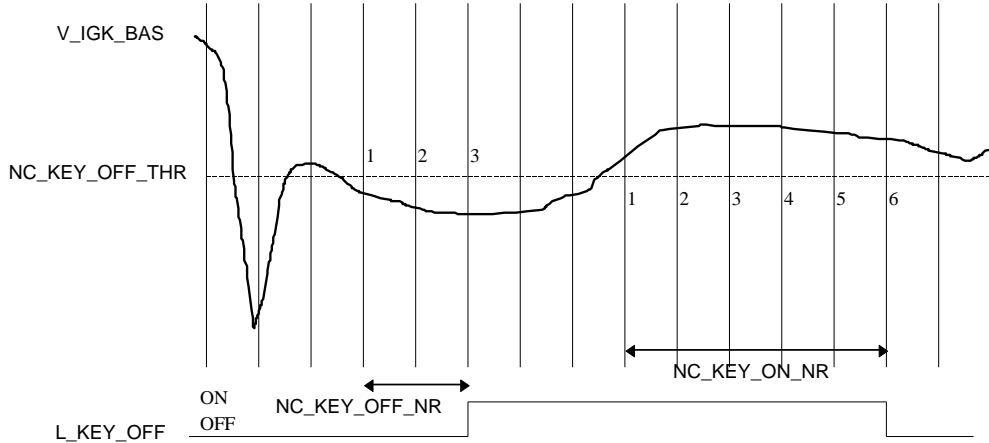

According to the battery voltage raw value (V_IGK_BAS) after ignition key, the ignition key ON / OFF recognition is performed.

Formula section:

Ignition key ON recognised :

if V_IGK_BAS > NC_KEY_OFF_THR
 for more than NC_KEY_ON_NR number of successive samples (* 1 msec.)
then L_KEY_OFF = 0 (ON)

Ignition key OFF recognised :

if V_IGK_BAS < NC_KEY_OFF_THR
 for more than NC_KEY_OFF_NR number of successive samples (* 1 msec.)
then L_KEY_OFF = 1 (OFF)

Calibration data:

Name	Type	Dim	Hex. limits	Phys. limits	Resol.	Unit
NC_KEY_OFF_THR	2U	1	0...03FFH	0...25,9746	26 / 1024	Volt
Battery voltage threshold for ignition key ON / OFF recognition.						
NC_KEY_OFF_NR	1U	1	0...FFH	0..255	1	-
Number of samples (battery voltage raw acquisition) for ignition key OFF validation.						
NC_KEY_ON_NR	1U	1	0...FFH	0..255	1	-
Number of samples (battery voltage raw acquisition) for ignition key ON validation.						

Applicative Values : NC_KEY_OFF_THR = **00C4H** = 196 dec. = 5 Volt.
 NC_KEY_OFF_NR = **03H** = 3 dec. = 3 msec.
 NC_KEY_ON_NR = **06H** = 6 dec. = 6 msec.

Proprietary data, company confidential. All rights reserved.
 Contine a titre de secret d'entreprise. Tous droits réservés.
 Comunicado como segredo empresarial. Reservados todos os direitos.
 Confidado como secreto industrial. Nos reservamos todos los derechos.

Weitergabe sowie Vervielfältigung dieser Unterlage, Verwertung und Mitteilung ihres Inhalts nicht gestattet, soweit nicht ausdrücklich zugestanden. Zuwiderhandlungen verpflichten zu Schadensersatz. Alle Rechte vorbehalten, insbesondere für den Fall der Patenterteilung oder GM-Enttragung.

1.1.4.2 Applicative software

Output data:

Name	Type	V/S	Hex. limits	Phys. limits	Resol.	Unit
VB	1U	V	0...FFH	0...25,8984	26 / 256	Volt
Battery voltage.						
LV_IGK	Bool	V	0...01H	0...1	1	-
Boolean for ignition key status - (Passive / Active).						
LV_VB_JUMP	Bool	V	0...01H	0...1	1	-
Boolean for over voltage - (Passive / Active).						
LV_CDN_VB_OBD1	Bool	V	0...01H	0...1	1	-
Boolean for battery voltage condition fulfilled at OBD-I Variants.						
LV_CDN_VB_OBD2	Bool	V	0...01H	0...1	1	-
Boolean for battery voltage condition fulfilled at OBD-II Variants.						

Input data:

VB_MES	L_KEY_OFF	V_IGK_MES	
--------	-----------	-----------	--

FUNCTION DESCRIPTION:

General information:

The application recurrence is **10 msec**.

1.1.4.3 Battery voltage

$$VB \leftarrow VB_MES / 4 \quad (8 \text{ bits})$$

$$V_IGK \leftarrow V_IGK_MES / 4 \quad (8 \text{ bits})$$

1.1.4.4 Ignition key detection

```

if    L_KEY_OFF = 0 (ON)
then  LV_IGK = 1 (Active)
else  LV_IGK = 0 (Passive)
    
```

1.1.4.5 Battery over voltage detection

```

if    VB ≤ C_VB_MIN_JUMP
and   V_IGK ≤ C_VB_MIN_JUMP
then  LV_VB_JUMP = 0 (Passive)
else  LV_VB_JUMP = 1 (Active)
    
```

Editor: Müller O.	17-Dec-97	Basic SW Inputs and Outputs	HMC_V6
Version: a 153589 from 18.12.97		657765.49.02	
File: CHAP_2.DOC	650H0000	Sourcefile:07200901.00A	Page 41 / 98

Proprietary data, company confidential. All rights reserved. Contine a titre de secret d'entreprise. Tous droits réservés. Comunicado como segredo empresarial. Reservados todos os direitos. Confidado como secreto industrial. Nos reservamos todos los derechos.

Weitergabe sowie Vervielfältigung dieser Unterlage, Verwertung und Mitteilung ihres Inhalts nicht gestattet, soweit nicht ausdrücklich zugestanden. Zuwiderhandlungen verpflichten zu Schadenersatz. Alle Rechte vorbehalten, insbesondere für den Fall der Patenterteilung oder GM-Entragung.

1.1.4.6 Low Battery voltage detection for OBD-I/II Diagnosis

```

if    VB < C_VB_MIN_OBD_1/2
or    V_IGK < C_VB_MIN_OBD_1/2
or    LV_IGK = 0
then  LV_CDN_VB_OBD1/2 = 0
else  LV_CDN_VB_OBD1/2 = 1
    
```

Calibration data:

Name	Type	Dim	Hex. limits	Phys. limits	Resol.	Unit
C_VB_MIN_JUMP	1U	1	0..FFH	0...25,8984	26 / 256	Volt
Battery voltage threshold for over voltage detection.						
C_VB_MIN_OBD1	1U	1	0..FFH	0...25,8984	26 / 256	Volt
Battery voltage threshold for low voltage detection for OBD-I Variants.						
C_VB_MIN_OBD2	1U	1	0..FFH	0...25,8984	26 / 256	Volt
Battery voltage threshold for low voltage detection for OBD-II Variants.						

Proprietary data, company confidential. All rights reserved.
 Contine a titre de secret d'entreprise. Tous droits réservés.
 Comunicado como segredo empresarial. Reservados todos os direitos.
 Confidado como secreto industrial. Nos reservamos todos los derechos.

Weitergabe sowie Vervielfältigung dieser Unterlage, Verwertung und Mitteilung ihres Inhalts nicht gestattet, soweit nicht ausdrücklich zugestanden. Zuwiderhandlungen verpflichten zu Schadensersatz. Alle Rechte vorbehalten, insbesondere für den Fall der Patenterteilung oder GM-Entragung.

Editor: Müller O.	17-Dec-97	Basic SW Inputs and Outputs	HMC_V6
Version: a 153589 from 18.12.97		657765.49.02	
File: CHAP_2.DOC	650H0000	Sourcefile:07200901.00A	Page 42 / 98

1.1.5 Acquisition of oxygen sensor voltage

1.1.5.1 Basic software

Output data:

Name	Mode	Hex. limits	Phys. limits	Resol.	Unit
VLS_1_MES	-	0...FFH	0...4.9805	5 / 256	Volt
Upstream oxygen sensor voltage value measured (8 bits) - Bank n° 1.					
VLS_2_MES	-	0...FFH	0...4.9805	5 / 256	Volt
Upstream oxygen sensor voltage value measured (8 bits) - Bank n° 2.					
VLS_CAT_1_MES	-	0...FFH	0...4.9805	5 / 256	Volt
Downstream oxygen sensor voltage value measured (8 bits) - Bank n° 1.					
VLS_CAT_2_MES	-	0...FFH	0...4.9805	5 / 256	Volt
Downstream oxygen sensor voltage value measured (8 bits) - Bank n° 2.					

Input data:

VLS_UP_1_BAS	VLS_UP_2_BAS	VLS_DOWN_1_BAS	VLS_DOWN_2_BAS
--------------	--------------	----------------	----------------

FUNCTION DESCRIPTION:

General information:

The raw value for oxygen sensor voltage (VLS_UP_i_BAS or VLS_DOWN_i_BAS) is measured by continuous conversion (10 bits) every 1 msec.

Formula section:

VLS_1_MES	←	VLS_UP_1_BAS / 4	(8 bits)
VLS_2_MES	←	VLS_UP_2_BAS / 4	(8 bits)
VLS_CAT_1_MES	←	VLS_DOWN_1_BAS / 4	(8 bits)
VLS_CAT_2_MES	←	VLS_DOWN_2_BAS / 4	(8 bits)

Proprietary data, company confidential. All rights reserved.
 Contit a titre de secret d'entreprise. Tous droits réservés.
 Comunicado como segredo empresarial. Reservados todos os direitos.
 Confidado como secreto industrial. Nos reservamos todos los derechos.

Weitergabe sowie Vervielfältigung dieser Unterlage, Verwertung und Mitteilung ihres Inhalts nicht gestattet, soweit nicht ausdrücklich zugestanden. Zuwiderhandlungen verpflichten zu Schadensersatz. Alle Rechte vorbehalten, insbesondere für den Fall der Patenterteilung oder GM-Entragung.

Editor: Müller O.	17-Dec-97	Basic SW Inputs and Outputs	HMC_V6
Version: a 153589 from 18.12.97		657765.49.02	
File: CHAP_2.DOC	650H0000	Sourcefile:07201P01.00A	Page 43 / 98

1.1.5.2 Applicative software

Output data:

Name	Mode	Hex. limits	Phys. limits	Resol.	Unit
VLS_1	V	0...FFH	0...4.9805	5 / 256	Volt
Upstream oxygen sensor voltage - Bank n° 1.					
VLS_2	V	0...FFH	0...4.9805	5 / 256	Volt
Upstream oxygen sensor voltage - Bank n° 2.					
VLS_CAT_1	V	0...FFH	0...4.9805	5 / 256	Volt
Downstream oxygen sensor voltage - Bank n° 1.					
VLS_CAT_2	V	0...FFH	0...4.9805	5 / 256	Volt
Downstream oxygen sensor voltage - Bank n° 2.					

Input data:

VLS_1_MES	VLS_2_MES	VLS_CAT_1_MES	VLS_CAT_2_MES
-----------	-----------	---------------	---------------

FUNCTION DESCRIPTION:

General information:

The application recurrence for VLS_1 and VLS_2 is **10 msec.**

The oxygen sensor voltages VLS_i are used mainly for A/F regulation.

They are also used for auxiliary functions like evaporative emissions control and catalyst overheating protection.

The OBDII diagnosis functions require also this data.

The oxygen sensor voltages VLS_CAT_i are used for OBDII diagnosis, mainly catalyst efficiency monitoring.

Formula section:

VLS_1	←	VLS_1_MES	(8 bits)
VLS_2	←	VLS_2_MES	(8 bits)
VLS_CAT_1	←	VLS_CAT_1_MES	(8 bits)
VLS_CAT_2	←	VLS_CAT_2_MES	(8 bits)

Proprietary data, company confidential. All rights reserved. Contine a titre de secret d'entreprise. Tous droits réservés. Comunicado como segredo empresarial. Reservados todos os direitos. Confidado como secreto industrial. Nos reservamos todos los derechos.

Weitergabe sowie Vervielfältigung dieser Unterlage, Verwertung und Mitteilung ihres Inhalts nicht gestattet, soweit nicht ausdrücklich zugestanden. Zuwiderhandlungen verpflichten zu Schadenersatz. Alle Rechte vorbehalten, insbesondere für den Fall der Patenterteilung oder GM-Enttragung

Editor: Müller O.	17-Dec-97	Basic SW Inputs and Outputs	HMC_V6
Version: a 153589 from 18.12.97		657765.49.02	
File: CHAP_2.DOC	650H0000	Sourcefile:07201P01.00A	Page 44 / 98

1.1.6 Acquisition of coolant temperature

1.1.6.1 Basic software

Output data:

Name	Mode	Hex. limits	Phys. limits	Resol.	Unit
TCO_MES	-	0...FEH	-48...142,5	0,75	°C
Coolant temperature value measured.					
V_TCO	V	0...FFFFH	0...4,9951	5 / 1024	Volt
Coolant temperature voltage raw value (10 bits).					

Input data:

TCO_BAS			
---------	--	--	--

FUNCTION DESCRIPTION:

General information:

This function is applicable with a NTC type of sensor.

The raw value for coolant temperature (TCO_BAS) is measured by continuous conversion (10 bits) every 1 msec.

The value of the numeric conversion is adapted to take into account of the electronic component drift. The result of this adaptation must be linearized according to temperature sensor response.

The corresponding value of the first measurement after hardware reset is used for initialisation.

Formula section:

The coolant temperature TCO_MES is obtained by linearization of the formatted acquisition with a specific table IP_TCO_TAB__V_TCO with :

$$V_TCO \leftarrow TCO_BAS * 64 \quad (10 \text{ bits})$$

Calibration data:

Name	Dim	Hex. limits	Phys. limits	Resol.	Unit
IP_TCO_TAB__V_TCO	16	0...FEH	-48...142,5	0,75	°C
Conversion table for linearization of TCO value acquisition.					

1.1.7 Acquisition of air intake temperature

1.1.7.1 Basic software

Output data:

Name	Mode	Hex. limits	Phys. limits	Resol.	Unit
TIA_MES	-	0...FEH	-48...142,5	0,75	°C
Air intake temperature value measured.					
V_TIA	V	0...FFH	0...4,9805	5 / 256	Volt
Air intake temperature voltage raw value (8 bits).					

Input data:

TIA_BAS			
---------	--	--	--

FUNCTION DESCRIPTION:

General information:

This function is applicable with a NTC type of sensor.

The raw value for air intake temperature (TIA_BAS) is measured by continuous conversion (10 bits) every 1 msec.

The value of the numeric conversion is adapted to take into account of the electronic component drift. The result of this adaptation must be linearized according to the temperature sensor response.

The corresponding value of the first measurement after hardware reset is used for initialization.

Formula section:

The air intake temperature TIA_MES is obtained by linearization of the formatted acquisition with a specific table IP_TIA_TAB__V_TIA with :

$$V_TIA \leftarrow TIA_BAS / 4 \quad (8 \text{ bits})$$

Calibration data:

Name	Dim	Hex. limits	Phys. limits	Resol.	Unit
IP_TIA_TAB__V_TIA	16	0...FEH	-48...142,5	0,75	°C
Conversion table for linearization of TIA value acquisition.					

Proprietary data, company confidential. All rights reserved. Contient des informations confidentielles. Tous droits réservés. Comunicado como segredo empresarial. Reservados todos os direitos. Comunicado como secreto industrial. Nos reservamos todos los derechos.

Weitergabe sowie Vervielfältigung dieser Unterlage, Verbreitung und Mitteilung ihres Inhalts nicht gestattet, soweit nicht ausdrücklich zugestanden. Zuwiderhandlungen verpflichten zu Schadensersatz. Alle Rechte vorbehalten, insbesondere für den Fall der Patenterteilung oder GM-Enttragung.

Editor: Müller O.	17-Dec-97	Basic SW Inputs and Outputs	HMC_V6
Version: a 153589 from 18.12.97		657765.49.02	
File: CHAP_2.DOC	650H0000	Sourcefile:07201R01.00B	Page 46 / 98

1.1.8 Acquisition of exhaust gas temperature

1.1.8.1 Basic software

Output data:

Name	Mode	Hex. limits	Phys. limits	Resol.	Unit
TEG_MES	-	0...FEH	-48...142.5	0.75	°C
Exhaust gas temperature value measured.					
V_TEG	-	0...03FFH	0...4.9951	5 / 1024	Volt
Exhaust gas temperature voltage raw value (10 bits).					

Input data:

TEG_BAS			
---------	--	--	--

FUNCTION DESCRIPTION:

General information:

This function is applicable with a NTC type of sensor.

The raw value for coolant temperature (TEG_BAS) is measured by continuous conversion (10 bits) every 1 msec.

The value of the numeric conversion is adapted to take into account of the electronic component drift. The result of this adaptation must be linearized according to temperature sensor response.

The corresponding value of the first measurement after hardware reset is used for initialisation.

Formula section:

The coolant temperature TEG_MES is obtained by linearization of the formatted acquisition with a specific table IP_TEG_TAB__V_TEG with :

$$V_TEG \leftarrow TEG_BAS * 64 \quad (10 \text{ bits})$$

Calibration data:

Name	Dim	Hex. limits	Phys. limits	Resol.	Unit
IP_TEG_TAB__V_TEG	16	0...FEH	-48...142.5	0.75	°C
Conversion table for linearization of TEG value acquisition.					

Editor: Müller O.	17-Dec-97	Basic SW Inputs and Outputs	HMC_V6
Version: a 153589 from 18.12.97		657765.49.02	
File: CHAP_2.DOC	650H0000	Sourcefile:07201T01.00A	Page 47 / 98

1.2 Logic Inputs

1.2.1 Basic software

Output data:

Name	Mode	Hex. limits	Phys. limits	Resol.	Unit
LV_IM_ACIN	-	0...01H	0...1	1	-
Air Condition selected.					
L_IM_ACCIN	-	0...01H	0...1	1	-
Air Condition request.					
LV_IM_PRS_ACC	-	0...01H	0...1	1	-
Pressure switch of Air Condition circuit.					
LV_IM_PVD	-	0...01H	0...1	1	-
Primary Voltage Diagnosis.					
LV_IM_MIL_FLL_REQ	-	0...01H	0...1	1	-
Malfunction Indicator Light for Engine Control Unit - Request line for blink code.					
LV_IM_VB_OFF	-	0...01H	0...1	1	-
Battery disconnected.					
LV_IM_EL_LOAD	-	0...01H	0...1	1	-
Electrical load input.					

FUNCTION DESCRIPTION:

List of logic Inputs

Name	Port - Channel	Logic state
L_PIN_PRS_ACC	3 - 1	Positive Logic
L_PIN_ACIN	3 - 4	Positive Logic
L_PIN_ACCIN	3 - 5	Positive Logic
L_PIN_PVD	3 - 7	* - Positive Logic
L_PIN_MIL_FLL_REQ	3 - 14	Positive Logic
L_PIN_EL_LOAD	3 - 6	Positive Logic
L_PIN_VB_OFF	8 - 6	Positive Logic

* : ECU Internal Signal

Proprietary data, company confidential. All rights reserved.
 Contient des informations confidentielles. Tous droits réservés.
 Comunicado como segredo empresarial. Reservados todos os direitos.
 Confidado como secreto industrial. Nos reservamos todos los derechos.

Weitergabe sowie Vervielfältigung dieser Unterlage, Verwertung und Mitteilung ihres Inhalts ist gestattet, soweit nicht ausdrücklich zugestanden. Zuwiderhandlungen verpflichten zu Schadensersatz. Alle Rechte vorbehalten, insbesondere für den Fall der Patenterteilung oder GM-Entragung.

Editor: Müller O.	17-Dec-97	Basic SW Inputs and Outputs	HMC_V6
Version: a 153589 from 18.12.97		657765.49.02	
File: CHAP_2.DOC	650H0000	Sourcefile:07200G01.00C	Page 48 / 98

1.2.2 Applicative software

Output data:

Name	Mode	Hex. limits	Phys. limits	Resol.	Unit
LV_DRI	V	0...01H	0...1	1	-
Boolean for DRIVE or REVERSE engaged (- / DRI).					
LV_GS	V	0...01H	0...1	1	-
Boolean for GEAR SHIFT signal (- / GS).					
LV_ACIN	V	0...01H	0...1	1	-
Air condition selected (- / ACIN).					
LV_ACCIN	V	0...01H	0...1	1	-
Air condition requested (- / ACCIN).					
LV_PRS_ACC	V	0...01H	0...1	1	-
Air condition switch requested (- / PRS_ACC).					
LV_VB_OFF	V	0...01H	0...1	1	-
Battery disconnected.					
LV_VB_OFF_ACT	V	0...01H	0...1	1	-
Filtered battery disconnected information bit.					
LV_EL_LOAD	V	0...01H	0...1	1	-
Electric load.					
LV_SET	V	0...01H	0...1	1	-
information of One-Bit Memory reset					

Input data:

LV_IM_DRI	LV_IM_GS	LV_IM_ACIN	L_IM_ACCIN
LV_IM_VB_OFF	LV_IM_EL_LOAD	LV_IM_PRS_ACC	TAR_GC
SWI_GS	CONF_TCU	CONF_NVMY_RST	

FUNCTION DESCRIPTION:

Formula section:

1 - Air-condition system :

$$\begin{aligned}
 LV_ACIN &= LV_IM_ACIN \\
 LV_ACCIN &= L_IM_ACCIN \\
 LV_PRS_ACC &= LV_IM_PRS_ACC
 \end{aligned}$$

Proprietary data, company confidential. All rights reserved. Contine a titre de secret d'entreprise. Tous droits réservés. Comunicado como segredo empresarial. Reservados todos os direitos. Confidado como secreto industrial. Nos reservamos todos los derechos.

Weitergabe sowie Vervielfältigung dieser Unterlage, Verwertung und Mitteilung ihres Inhalts nicht gestattet, soweit nicht ausdrücklich zugestanden. Zuwiderhandlungen verpflichten zu Schadenersatz. Alle Rechte vorbehalten, insbesondere für den Fall der Patenterteilung oder GM-Entragung.

Editor: Müller O.	17-Dec-97	Basic SW Inputs and Outputs	HMC_V6
Version: a 153589 from 18.12.97		657765.49.02	
File: CHAP_2.DOC	650H0000	Sourcefile:07200G01.00C	Page 49 / 98

2 - Automatic transmission system :

```

if          CONF_TCU = 1
           and   TAR_GC > 0           (Drive engaged)
           then  LV_DRI = 1
           and   LV_GS = SWI_GS      (from CAN from TCU)
           else  LV_DRI = LV_GS = 0
    
```

Remark: For more detailed information please refer to the CAN-Specification.

3 - Battery off detection:

General information:

A hardware with One-Bit Memory characteristic is provided to detect at system start up if the ECU or the battery was disconnected since the last power latch phase.

If a disconnection is detected and the system is not coded to OBD-II, the following values (mainly the failure memory and adaptation values) will be reset:

- Altitude Correction (MAF_FAC_ALTI_MMV)
- Knock Adaptation (ID_IGA_AD_[CYL]__N_KNK__MAF_KNK)
- TPS Adaptation (TPS_AD_MMV_IS)
- Lambda Adaptation (TI_AD_ADD_MMV_i, TI_AD_FAC_MMV_i)
- ISA Adaptation (ISAPWM_AD_MMV_IS, ISAPWM_DRI_AD_MMV_IS, ISAPWM_ACCIN_AD_MMV_IS)
- Idle Charge Actuator Adaptation (AD_INI_COR_ISA)
- Segment Time Adaptation (SEG_AD_[CYL])
- Fuel Trim Adaptation (T_DLY_AD_i)
- ASR Statistic Counter
- Restart Detection
- Idle Speed CO-Trim
- Fuel System Diagnosis debounce counter
- Secondary Air Values
- OBD Trip Counter
- Failure Memory
- Camshaft edge adaptation

Application recurrence: once after system reset.

```

if          CONF_NVMY_RST = 1           (Erasurement of non volatile data
                                           configured)
           then  LV_VB_OFF_ACT = LV_VB_OFF      (One-Bit Memory is set)
           and   therefore the above listed values are reset
           else  LV_VB_OFF_ACT = 0           (reset One-Bit Memory)
    
```

After the power latch phase the One-Bit Memory is reset (LV_SET = 1) for at least 50 ms.

Editor: Müller O.	17-Dec-97	Basic SW Inputs and Outputs	HMC_V6
Version: a 153589 from 18.12.97		657765.49.02	
File: CHAP_2.DOC	650H0000	Sourcefile:07200G01.00C	Page 50 / 98

1.2.3 Acquisition of crankshaft signal

1.2.3.1 Basic software

Output data:

Name	Mode	Hex. limits	Phys. limits	Resol.	Unit
T_TOOTH	-	0...FFFFH	0...65535	4 µsec	sec
Tooth time.					
TOOTH_GRD	-	0...FFH	0...255	1	-
Tooth gradient (0080H = 0.5, 0100H = 1, 0200H = 2 ...)					
CAM_LEVEL_SHR	-	0...FFH	0...255	1	-
Camshaft level shift register for validation of camshaft level.					
LV_RUN_ENG	-	0...01H	0...1	1	-
Boolean information for engine running detection.					
LV_SYN_ENG	-	0...01H	0...1	1	-
Boolean information for complete engine synchronisation.					
LV_LOW_N	-	0...01H	0...1	1	-
Boolean information for too low engine speed detection.					
CRK_VALID_TEETH_CNT	-	0...FFH	0...255	1	-
Crankshaft valid teeth counter for synchronisation.					
T_SEG	-	0...FFFFFFFFH	0...4294967295	4 µsec	sec
Segment period.					
TOOTH_COUNTER	-	0...FFH	0...255	1	-
Tooth numbering.					

FUNCTION DESCRIPTION:

General information:

This function synchronizes the software with the engine, detects engine stopped (or running) and provides the tooth number and segment period.

The complete algorithm is included in the basic software without any specific pre-treatment.

The input signal is provided by a **60 - 2** crankshaft target wheel. The first active edge after the gap (two missing teeth) should be not later than **78 °CRK** before TDC. It is required to avoid ignition event inside the crankshaft gap (maximum spark advance before TDC : **72 °CRK**).

The resolution of the crankshaft position depends on the CPU frequency NC_F_CPU.

- The timer used for misfire detection use a clock NC_F_CPU / 16
(→ 16 Mhz / 16 = 1 Mhz → resolution of **1 µsec**)
- The timer used for engine speed calculation use a clock NC_F_CPU / 64
(→ 16 Mhz / 64 = 0,25 Mhz → resolution of **4 µsec**)

This resolution is used in the complete engine speed range (for cranking and normal engine speed).

Editor: Müller O.	17-Dec-97	Basic SW Inputs and Outputs	HMC_V6
Version: a 153589 from 18.12.97		657765.49.02	
File: CHAP_2.DOC	650H0000	Sourcefile:07200H01.00A	Page 51 / 98

1.2.3.1.1 Hardware configurable parameters

1.2.3.1.1.1 Active crankshaft edge definition

The active edge is defined by a non applicative calibration **NC_ACTIVE_CRK_EDGE**.

If **NC_ACTIVE_CRK_EDGE = 0** then “Crankshaft falling edge is active”

If **NC_ACTIVE_CRK_EDGE = 1** then “Crankshaft rising edge is active”

1.2.3.1.1.2 Minimum and maximum engine speed

The minimum engine speed **NC_N_MIN** defines :

- the maximum length of normal tooth :

$$\mathbf{NC_T_TOOTH_MAX} = \mathbf{NC_T1_FREQ} / \mathbf{NC_N_MIN}$$

- the maximum segment duration for engine stalling detection :

$$\mathbf{NC_T_SEG_MAX} = (\mathbf{NC_T1_FREQ} * \mathbf{120} / \mathbf{NC_CYL_NO}) / \mathbf{NC_N_MIN}$$

The maximum engine speed **NC_N_MAX** defines :

- the minimum length of normal tooth :

$$\mathbf{NC_T_TOOTH_MIN} = \mathbf{NC_T1_FREQ} / \mathbf{NC_N_MAX}$$

The minimum engine speed **NC_LOW_N** defines :

- the maximum segment duration for low engine speed range :

$$\mathbf{NC_T_SEG_LOW_N} = (\mathbf{NC_T1_FREQ} * \mathbf{120} / \mathbf{NC_CYL_NO}) / \mathbf{NC_LOW_N}$$

Remark : **NC_LOW_N > NC_N_MIN**

Editor:	Müller O.	17-Dec-97	Basic SW Inputs and Outputs	HMC_V6
Version:	a 153589 from 18.12.97		657765.49.02	
File:	CHAP_2.DOC	650H0000	Sourcefile:07200H01.00A	Page 52 / 98

Formula section:

1.2.3.1.2 Tooth time T_TOOTH calculation

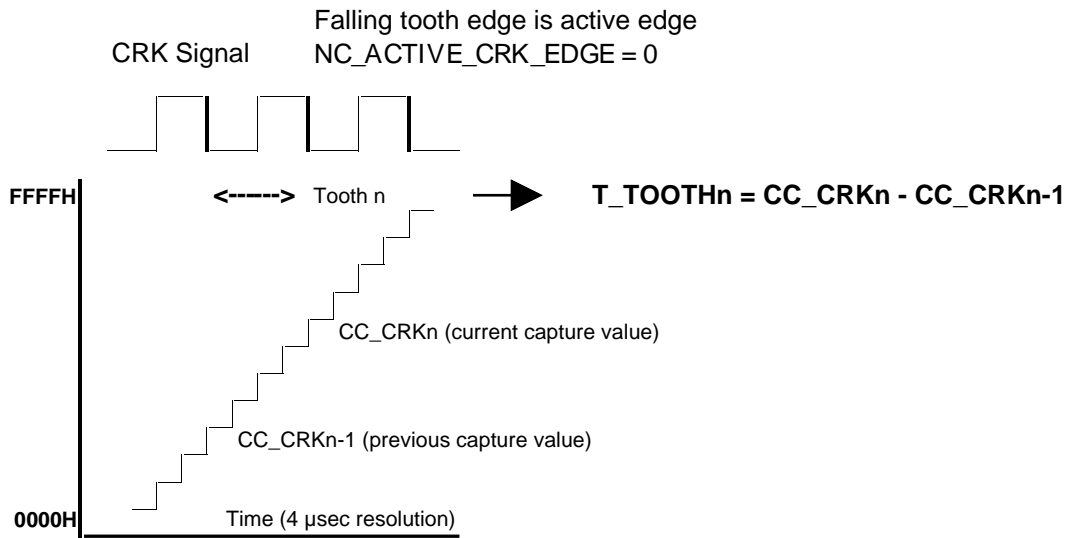

1.2.3.1.3 Tooth gradient TOOTH_GRD calculation

The tooth gradient is calculated only when LV_SYN_ENG = 0.
(→ engine running detected and synchronisation ongoing)

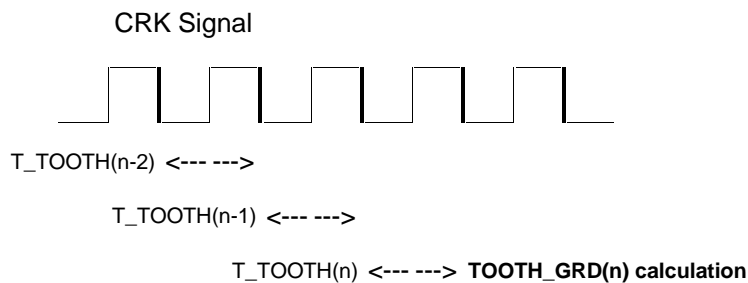

$$TOOTH_GRD(n) = [T_TOOTH(n) * T_TOOTH(n-2)] / [T_TOOTH(n-1) * T_TOOTH(n-1)]$$

Remark : This algorithm is only for detection of discontinuity on the crankshaft signal like crankshaft gap or spikes. When the crankshaft signal is continuous, TOOTH_GRD = 1.

Proprietary data, company confidential. All rights reserved.
 Contit a titre de secret d'entreprise. Tous droits réservés.
 Comunicado como segredo empresarial. Reservados todos os direitos.
 Confidado como secreto industrial. Nos reservamos todos los derechos.

Weitergabe sowie Vervielfältigung dieser Unterlage, Verwertung und Mitteilung ihres Inhalts nicht gestattet, soweit nicht ausdrücklich zugestanden. Zuwiderhandlungen verpflichten zu Schadensersatz. Alle Rechte vorbehalten, insbesondere für den Fall der Patenterteilung oder GM-Entragung

Editor: Müller O.	17-Dec-97	Basic SW Inputs and Outputs	HMC_V6
Version: a 153589 from 18.12.97		657765.49.02	
File: CHAP_2.DOC	650H0000	Sourcefile:07200H01.00A	Page 53 / 98

1.2.3.1.4 Camshaft level shift register CAM_LEVEL_SHR

The camshaft level shift register is a word (16 bits) and the least significant bits give the validation of the camshaft level at the crankshaft gap.

During synchronisation phase (beginning from engine stopped) :

- if electrical level on the hardware port is high **then** the corresponding bit from CAM_LEVEL_SHR is set to 1.
- if electrical level on the hardware port is low **then** the corresponding bit from CAM_LEVEL_SHR is set to 0.

If CAM_LEVEL_SHR(bit 0) to CAM_LEVEL_SHR(bit NC_CAM_LEVEL_SHR_NO - 1) = 0 or CAM_LEVEL_SHR (bit 0) to CAM_LEVEL_SHR(bit NC_CAM_LEVEL_SHR_NO - 1) = 1 **then** camshaft level is validated as soon as the crankshaft gap has crossed once.

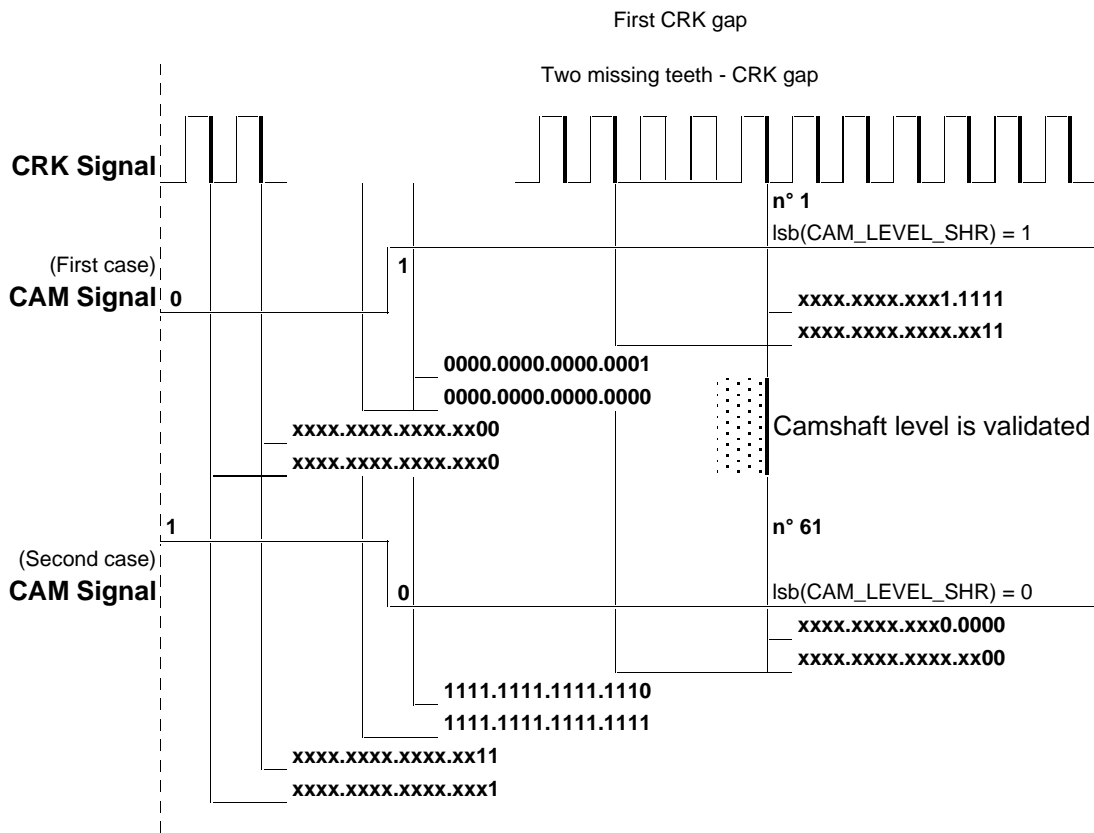

Proprietary data, company confidential. All rights reserved. Contient des informations confidentielles. Tous droits réservés. Comunicado como segredo empresarial. Reservados todos os direitos. Confidado como secreto industrial. Nos reservamos todos los derechos.

Weitergabe sowie Vervielfältigung dieser Unterlage, Verwertung und Mitteilung ihres Inhalts nicht gestattet, soweit nicht ausdrücklich zugestanden. Zuwiderhandlungen verpflichten zu Schadensersatz. Alle Rechte vorbehalten, insbesondere für den Fall der Patenterteilung oder GM-Entragung.

Editor: Müller O.	17-Dec-97	Basic SW Inputs and Outputs	HMC_V6
Version: a 153589 from 18.12.97		657765.49.02	
File: CHAP_2.DOC	650H0000	Sourcefile:07200H01.00A	Page 54 / 98

1.2.3.1.5 Tooth number function TOOTH_COUNTER

Teeth are counted on each active edge from **1** to **120**. The tooth counter is valid only if LV_SYN_ENG = 1 (→ synchronisation effective) and out of crankshaft limp home.

TOOTH_COUNTER is set to **1** or **61** as soon as LV_SYN_ENG is set to 1, depending on the camshaft signal level.

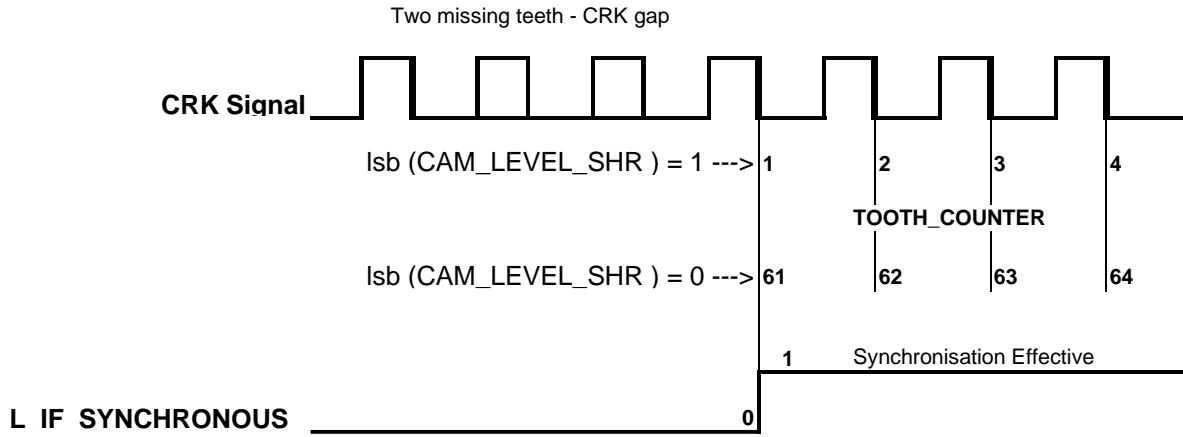

L IF SYNCHRONOUS

Proprietary data, company confidential. All rights reserved. Contine a titre de secret d'entreprise. Tous droits réservés. Comunicado como segredo empresarial. Reservados todos os direitos. Confidado como secreto industrial. Nos reservamos todos los derechos.

Weitergabe sowie Vervielfältigung dieser Unterlage, Verwertung und Mitteilung ihres Inhalts nicht gestattet, soweit nicht ausdrücklich zugestanden. Zuwiderhandlungen verpflichten zu Schadensersatz. Alle Rechte vorbehalten, insbesondere für den Fall der Patenterteilung oder GM-Eintragung.

Editor: Müller O.	17-Dec-97	Basic SW Inputs and Outputs	HMC_V6
Version: a 153589 from 18.12.97		657765.49.02	
File: CHAP_2.DOC	650H0000	Sourcefile:07200H01.00A	Page 55 / 98

1.2.3.1.6 Engine running detection LV_RUN_ENG

```

Initialisation :
LV_RUN_ENG = 0
Determination :
if ( NC_T_TOOTH_MIN ≤ T_TOOTH ≤ NC_T_TOOTH_MAX
and NC_TOOTH_GRD_MIN ≤ TOOTH_GRD ≤ NC_TOOTH_GRD_MAX)
    (determination of valid or invalid tooth)
then CRK_VALID_TEETH_CNTn = CRK_VALID_TEETH_CNTn-1 + 1
    (teeth counter incremented, only if active edge is valid)
    if CRK_VALID_TEETH_CNT = C_CRK_VLD_TOOTH
    then LV_RUN_ENG = 1
    (engine running detected)
    else CRK_VALID_TEETH_CNT = 0
    if T_TOOTH ≥ NC_T_TOOTH_MAX
    then " Engine Stopped " is detected
    else counting teeth process for valid tooth is performed again.
    
```

Remark : The crankshaft valid teeth counter is performed to anti-bounce the signal.

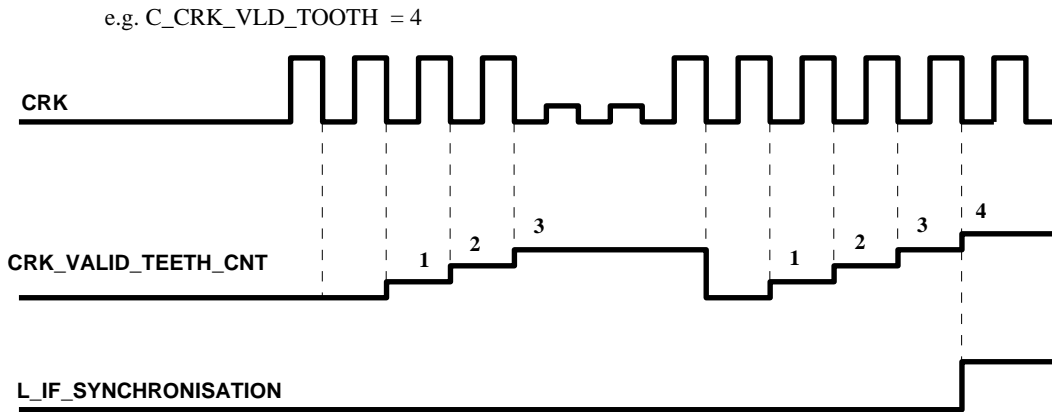

Proprietary data, company confidential. All rights reserved. Contine a titre de secret d'entreprise. Tous droits réservés. Comunicado como segredo empresarial. Reservados todos os direitos. Confidado como secreto industrial. Nos reservamos todos los derechos.

Weitergabe sowie Vervielfältigung dieser Unterlage, Verwertung und Mitteilung ihres Inhalts nicht gestattet, soweit nicht ausdrücklich zugestanden. Zuwiderhandlungen verpflichten zu Schadenersatz. Alle Rechte vorbehalten, insbesondere für den Fall der Patenterteilung oder GM-Enttragung

Editor: Müller O.	17-Dec-97	Basic SW Inputs and Outputs	HMC_V6
Version: a 153589 from 18.12.97		657765.49.02	
File: CHAP_2.DOC	650H0000	Sourcefile:07200H01.00A	Page 56 / 98

1.2.3.1.7 Engine synchronisation detection LV_SYN_ENG

Initialisation :
 LV_SYN_ENG = 0

Determination :

The algorithm is running as soon as LV_RUN_ENG is set to 1.

```

if T_TOOTH ≥ NC_T_TOOTH_MIN
and NC_TOOTH_GRD_MIN_GAP ≤ TOOTH_GRD ≤ NC_TOOTH_GRD_MAX_GAP
and T_TOOTH ≤ 3 * NC_T_TOOTH_MAX
and camshaft level valid (refer to “ Camshaft level shift register “ chapter)
    (searching for the crankshaft gap)
then LV_SYN_ENG = 1
    (crankshaft gap detected)
else
if ( T_TOOTH > 3 * NC_T_TOOTH_MAX
and NC_TOOTH_GRD_MIN_GAP ≤ TOOTH_GRD ≤ NC_TOOTH_GRD_MAX_GAP )
or T_TOOTH > NC_T_TOOTH_MAX
    (tooth time too long)
then “ Engine Stopped “ is detected
else
if ( T_TOOTH ≥ NC_T_TOOTH_MIN
or NC_TOOTH_GRD_MIN ≤ TOOTH_GRD ≤ NC_TOOTH_GRD_MAX )
then normal tooth is detected
else invalid tooth is detected and the valid teeth counter
    CRK_VALID_TEETH_CNT is reset.
    
```

TDC position determination :

The TDC (Top Dead Center) position is defined on the NC_NR_TOOTH_GAP_TDC + 1 active edge when LV_SYN_ENG is set to 1.

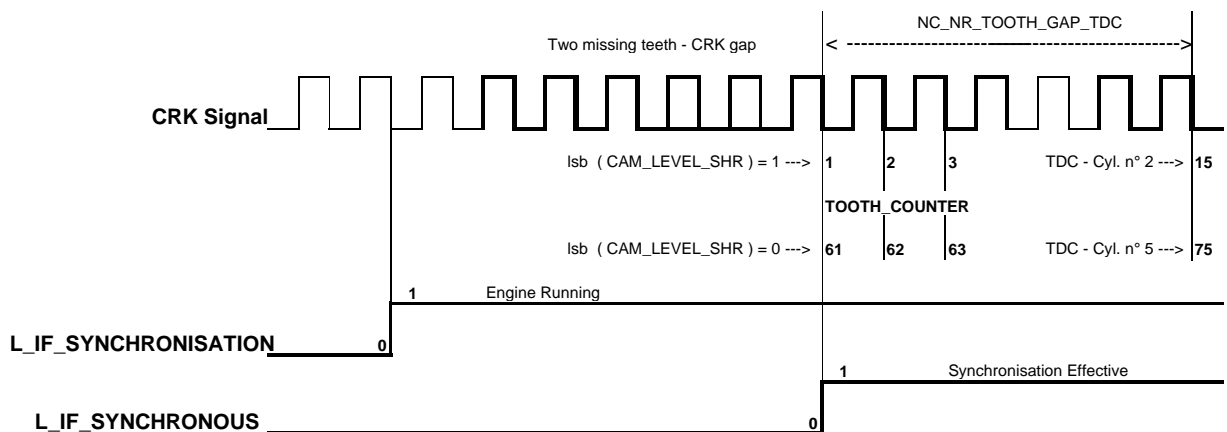

Proprietary data, company confidential. All rights reserved. Contine a titre de secret d'entreprise. Tous droits réservés. Comunicado como segredo empresarial. Reservados todos os direitos. Confidado como secreto industrial. Nos reservamos todos los derechos.

Weitergabe sowie Vervielfältigung dieser Unterlage, Verwertung und Mitteilung ihres Inhalts nicht gestattet, soweit nicht ausdrücklich zugestanden. Zuwiderhandlungen verpflichten zu Schadenersatz. Alle Rechte vorbehalten, insbesondere für den Fall der Patenterteilung oder GM-Entragung.

Editor: Müller O.	17-Dec-97	Basic SW Inputs and Outputs	HMC_V6
Version: a 153589 from 18.12.97		657765.49.02	
File: CHAP_2.DOC	650H0000	Sourcefile:07200H01.00A	Page 57 / 98

Proprietary data, company confidential. All rights reserved.
 Contient des données confidentielles de la société. Tous droits réservés.
 Comunicado como secreto empresarial. Reservados todos los derechos.
 Confiado como secreto industrial. Nos reservamos todos los derechos.

Weitergabe sowie Veröffentlichung dieser Unterlage, Verwertung und Mitteilung ihres Inhalts ist gestattet, soweit nicht ausdrücklich zugestanden. Zuwiderhandlungen verpflichten zu Schadenersatz. Alle Rechte vorbehalten, insbesondere für den Fall der Patenterteilung oder GM-Entragung.

1.2.3.1.8 Engine stalling detection

Determination :

```

if          LV_SYN_ENG = 1
              (synchronisation effective)
if          T_SEG > NC_T_SEG_MAX
              or T_TOOTH > NC_T_TOOTH_MAX
              (only if LV_LOW_N= 1 and outside the crankshaft gap range)
              or { no crankshaft signal available since the time out
                  NC_T_CRK_STL_FAST
                  (outside crankshaft limp home)
                  or no camshaft signal available since the time out
                  NC_T_CRK_STL_LIMP_HOME }
              (in crankshaft limp home)
then       engine stalling is detected
else
if          { one crankshaft active edge already detected and no crankshaft
              signal available since the time out
              NC_T_CRK_STL_SYNCHRONISATION
              or no camshaft signal available since the time out
              NC_T_CRK_STL_LIMP_HOME }
then       engine stalling is detected.
    
```

Calculation (resolution : 65,536 msec.)

$$NC_T_CRK_STL_FAST = (NC_T_CRK_STALL_FREQ / NC_N_MIN) / 65536$$

$$NC_T_CRK_STL_LIMP_HOME = (NC_T_CRK_STALL_FREQ * 60 / NC_N_MIN) / 65535$$

$$NC_T_CRK_STL_SYNCHRONISATION = (NC_T_CRK_STALL_FREQ * 3 / NC_N_MIN) / 65535$$

1.2.3.1.9 Segment period measurement T_SEG

Initialization :

$$T_SEG = \text{FFFFFFFFH}$$

Calculation :

Following synchronisation (LV_SYN_ENG = 1) after the crankshaft gap, the first segment time is calculated using the tooth time, like :

$$T_SEG = T_TOOTH * 120 / NC_CYL_NO$$

Editor: Müller O.	17-Dec-97	Basic SW Inputs and Outputs	HMC_V6
Version: a 153589 from 18.12.97		657765.49.02	
File: CHAP_2.DOC	650H0000	Sourcefile:07200H01.00A	Page 58 / 98

For the others, T_SEG calculation is using the raw crankshaft acquisition for 120 °CRK.
 (→ between tooth number **02** and **22**, **22** and **42**, **42** and **62**, **62** and **82**, **82** and **102** ...)

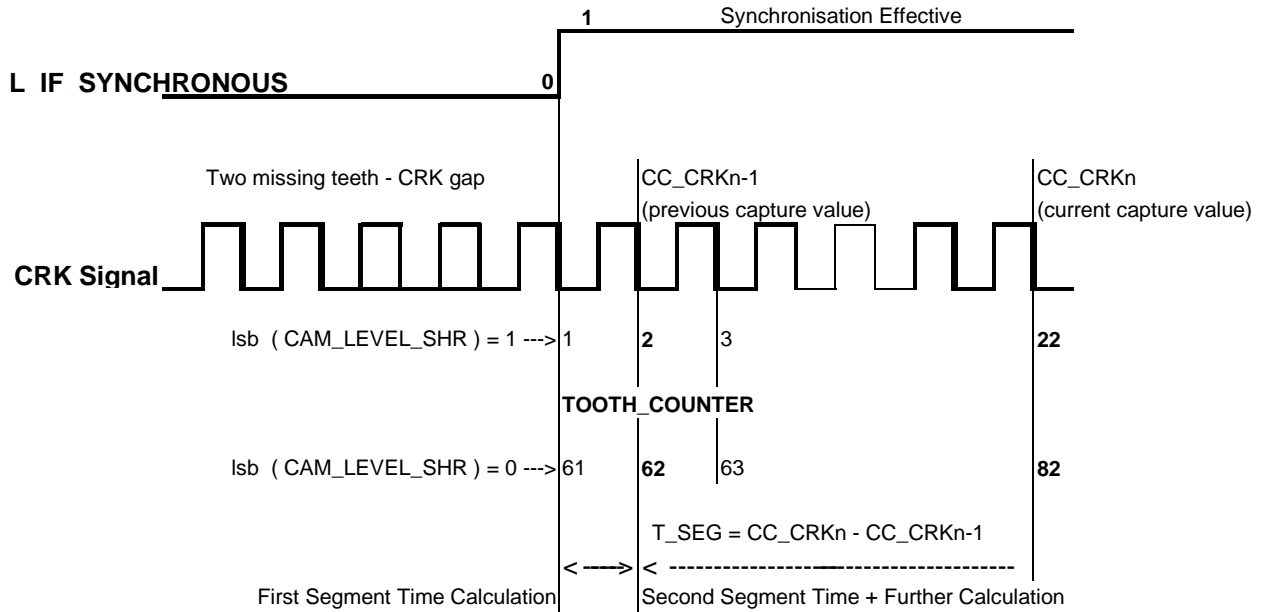

1.2.3.1.10 Low engine speed range determination LV_LOW_N

This engine speed range is dedicated for first injection application, engine stalling detection and calculation for dwell start.

Determination :

```

if          LV_SYN_ENG = 1
              (synchronisation effective)

then

              if          T_SEG > NC_T_SEG_LOW_N
              then        LV_LOW_N= 1 (low engine speed detected)
              else        LV_LOW_N = 0

else

              if          T_TOOTH > NC_T_SEG_LOW_N / (120 / NC_CYL_NO)
              then        LV_LOW_N = 1 (low engine speed detected)
              else        LV_LOW_N = 0
    
```

Proprietary data, company confidential. All rights reserved.
 Contient a titre de secret d'entreprise. Tous droits réservés.
 Comunicado como segredo empresarial. Reservados todos os direitos.
 Confidado como secreto industrial. Nos reservamos todos los derechos.

Weitergabe sowie Vervielfältigung dieser Unterlage, Verwertung und Mitteilung ihres Inhalts nicht gestattet, soweit nicht ausdrücklich zugestanden. Zuwiderhandlungen verpflichten zu Schadenersatz. Alle Rechte vorbehalten, insbesondere für den Fall der Patenterteilung oder GM-Entragung.

Editor: Müller O.	17-Dec-97	Basic SW Inputs and Outputs	HMC_V6
Version: a 153589 from 18.12.97		657765.49.02	
File: CHAP_2.DOC	650H0000	Sourcefile:07200H01.00A	Page 59 / 98

Calibration data:

Name	Dim	Hex. limits	Phys. limits	Resol.	Unit
NC_F_CPU	1			1	Hz
Micro-controller frequency - Non adjustable calibration.					
NC_ACTIVE_CRK_EDGE	1	0...01H	0...1	1	-
Active crankshaft edge definition - Non adjustable calibration.					
C_CRK_VLD_TOOTH	1	0...FFH	4...50	1	-
Number of valid teeth necessary for synchronisation when camshaft signal level is validated - Non adjustable calibration.					
NC_N_MIN	1	0...1FE0H	0...8160	1	rpm
Minimum engine speed - Non adjustable calibration.					
NC_LOW_N	1	0...1FE0H	0...8160	1	rpm
Low engine speed range - Non adjustable calibration.					
NC_N_MAX	1	0...FFFFH	0...65535	1	rpm
Maximum engine speed - Non adjustable calibration.					
NC_T1_FREQ	1			1	Hz
Timer frequency - Non adjustable calibration.					
NC_CYL_NO	1	0...FFH	0...255	1	-
Number of cylinders - Non adjustable calibration.					
NC_CAM_LEVEL_SHR_NO	1	0...FFH	0...255	1	-
Number of teeth for camshaft level validation - Non adjustable calibration.					
NC_TOOTH_GRD_MIN	1	0...1000H	0...16	0,0039	-
Minimum tooth gradient for valid or invalid tooth detection.					
NC_TOOTH_GRD_MAX	1	0...1000H	0...16	0,0039	-
Maximum tooth gradient for valid or invalid tooth duration.					
NC_TOOTH_GRD_MIN_GAP	1	0...1000H	0...16	0,0039	-
Minimum tooth gradient for valid or invalid crankshaft gap detection.					
NC_TOOTH_GRD_MAX_GAP	1	0...1000H	0...16	0,0039	-
Maximum tooth gradient for valid or invalid crankshaft gap detection.					
NC_NR_TOOTH_GAP_TDC	1	0...FFH	0...255	1	-
Number of teeth after crankshaft gap for TDC reference - Non adjustable calibration.					
NC_T_CRK_STALL_FREQ	1			1	Hz
Timer frequency for time out calculation when crankshaft signal is not available for engine stalling detection - Non adjustable calibration.					

Proprietary data, company confidential. All rights reserved. Contine a titre de secret d'entreprise. Tous droits réservés. Comunicado como segredo empresarial. Reservados todos os direitos. Confidado como secreto industrial. Nos reservamos todos los derechos.

Weitergabe sowie Vervielfältigung dieser Unterlage, Verbreitung und Mitteilung ihres Inhalts nicht gestattet, soweit nicht ausdrücklich zugestanden. Zuwiderhandlungen verpflichten zu Schadenersatz. Alle Rechte vorbehalten, insbesondere für den Fall der Patenterteilung oder GM-Entragung.

Editor: Müller O.	17-Dec-97	Basic SW Inputs and Outputs	HMC_V6
Version: a 153589 from 18.12.97		657765.49.02	
File: CHAP_2.DOC	650H0000	Sourcefile:07200H01.00A	Page 60 / 98

Applicative Value :

NC_F_CPU = 16 MHz
 NC_ACTIVE_CRK_EDGE = 00H = 0 dec.
 NC_VALID_TEETH_SYNC = 18H = 24 teeth
 NC_N_MIN = 001EH = 30 rpm
 NC_N_MAX = 2008H = 8200 rpm
 NC_LOW_N = 01F4H = 500 rpm
 NC_T1_FREQ = 250 kHz
 NC_CYL_NO = 06H = 6 cylinders
 NC_CAM_LEVEL_SHR_NO = 02H = 2 dec.
 NC_TOOTH_GRD_MIN = 0080H = 0,5
 NC_TOOTH_GRD_MAX = 0200H = 2
 NC_TOOTH_GRD_MIN_GAP = 0280H = 2,5
 NC_TOOTH_GRD_MAX_GAP = 0380H = 3,5
 NC_NR_TOOTH_GAP_TDC = 0EH = 14 teeth
 NC_T_CRK_STALL_FREQ = 1 MHz

Proprietary data, company confidential. All rights reserved.
 Contient des données confidentielles de l'entreprise. Tous droits réservés.
 Comunicado como secreto empresarial. Reservados todos los derechos.
 Confidado como secreto industrial. Nos reservamos todos los derechos.

Weitergabe sowie Vervielfältigung dieser Unterlage, Wertung und Mitteilung ihres Inhalts nicht gestattet, soweit nicht ausdrücklich zugestanden. Zuwiderhandlungen verpflichten zu Schadensersatz. Alle Rechte vorbehalten, insbesondere für den Fall der Patenterteilung oder GM-Entragung.

Editor:	Müller O.	17-Dec-97	Basic SW Inputs and Outputs	HMC_V6
Version:	a 153589 from 18.12.97		657765.49.02	
File:	CHAP_2.DOC	650H0000	Sourcefile:07200H01.00A	Page 61 / 98

1.2.4 Acquisition of camshaft signal

1.2.4.1 Basic software

Output data:

Name	Mode	Hex. limits	Phys. limits	Resol.	Unit
LV_CAM_1_LVL	-	0..01H	0..1	1	-
Boolean information for diagnosis evaluation set on camshaft interrupt (falling and rising edge).					
LV_CAM_1_EDGE	-	0..01H	0..1	1	-
Boolean information for diagnosis evaluation set on active camshaft edge.					
CAM_1_POS_TOOTH	1	0..78H	0..120	6	°CRK
Crankshaft tooth number when camshaft active edge occurs.					

Input data:

LV_SYN_ENG	LV_CRK_ERR_LIH	TOOTH_COUNTER	CAM_LEVEL_SHR
------------	----------------	---------------	---------------

FUNCTION DESCRIPTION:

General information:

The camshaft wheel is designed with 2 asymmetrical segments (170 ° high level, 190 ° low level).

Its signal is performed for synchronisation and limp home function.

Concerning synchronisation, the camshaft signal is strongly linked to the crankshaft signal and the edge of the camshaft should not be in the crankshaft gap (two missing teeth).

Proprietary data, company confidential. All rights reserved.
 Contit a titre de secret d'entreprise. Tous droits réservés.
 Comunicado como segredo empresarial. Reservados todos os direitos.
 Confidado como secreto industrial. Nos reservamos todos los derechos.

Weitergabe sowie Vervielfältigung dieser Unterlage, Verwertung und Mitteilung ihres Inhalts nicht gestattet, soweit nicht ausdrücklich zugestanden. Zuwiderhandlungen verpflichten zu Schadenersatz. Alle Rechte vorbehalten, insbesondere für den Fall der Patenterteilung oder GM-Entragung.

Editor: Müller O.	17-Dec-97	Basic SW Inputs and Outputs	HMC_V6
Version: a 153589 from 18.12.97		657765.49.02	
File: CHAP_2.DOC	650H0000	Sourcefile:07200J01.00A	Page 62 / 98

Formula section:

The measurement of the camshaft position, relative to the crankshaft signal is performed as soon as synchronization is effective (LV_SYN_ENG = 1).

Before synchronisation (engine running detection), only the level of the camshaft signal is evaluated (CAM_LEVEL_SHR).

* The camshaft position measurement is identified by three output datas :

- **CAM_1_POS_TOOTH** : Current value of the tooth counter TOOTH_COUNTER at camshaft signal interrupt.
- **LV_CAM_1_EDGE** : Boolean information set with camshaft signal interrupt and reset by the diagnosis algorithm for camshaft missing signal.
- **LV_CAM_1_LVL** : Boolean information set with camshaft interrupt (falling or rising edge) updated as soon as synchronisation is effective.

Remark : If LV_CRK_ERR_LIH = 1 (no crankshaft signal available), then CAM_1_POS_TOOTH and LV_CAM_1_EDGE are not updated.

Proprietary data, company confidential. All rights reserved.
 Contient des informations confidentielles. Tous droits réservés.
 Comunicado como segredo empresarial. Reservados todos os direitos.
 Confidado como secreto industrial. Nos reservamos todos los derechos.

Weitergabe sowie Vervielfältigung dieser Unterlage, Verwertung und Mitteilung ihres Inhalts nicht gestattet, soweit nicht ausdrücklich zugestanden. Zuwiderhandlungen verpflichten zu Schadensersatz. Alle Rechte vorbehalten, insbesondere für den Fall der Patenterteilung oder GM-Entragung.

Editor:	Müller O.	17-Dec-97	Basic SW Inputs and Outputs	HMC_V6
Version:	a 153589 from 18.12.97		657765.49.02	
File:	CHAP_2.DOC	650H0000	Sourcefile:07200J01.00A	Page 63 / 98

Description:

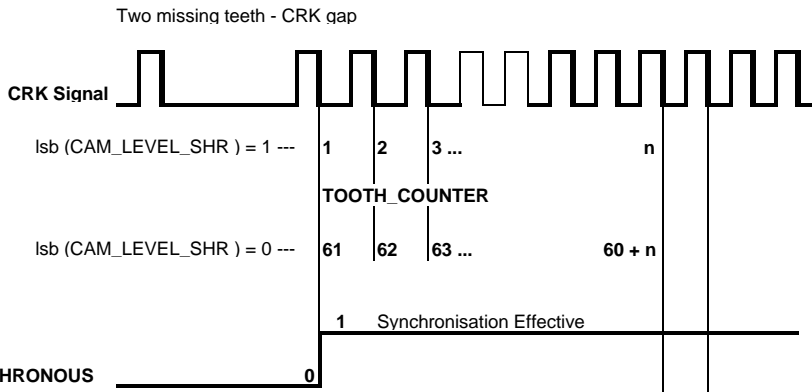

Case n° 1

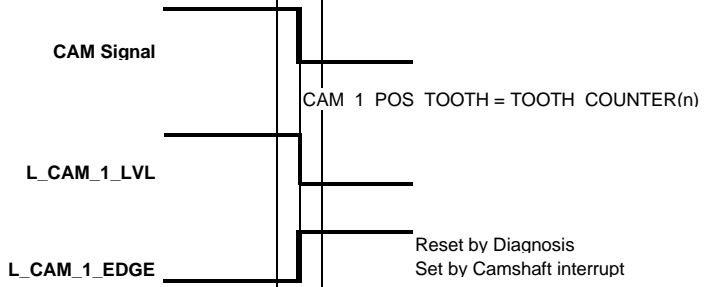

Case n° 2

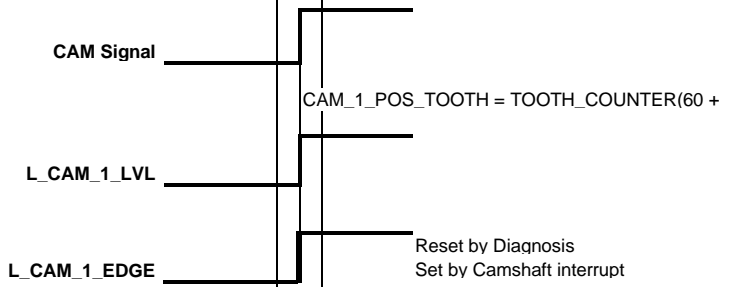

Proprietary data, company confidential. All rights reserved.
 Contient des informations confidentielles. Tous droits réservés.
 Comunicado como secreto empresarial. Reservados todos los derechos.
 Confiado como secreto industrial. Nos reservamos todos los derechos.

Weitergabe sowie Vervielfältigung dieser Unterlage, Verwertung und Mitteilung ihres Inhalts ist gestattet, soweit nicht ausdrücklich zugestanden. Zuwiderhandlungen verpflichten zu Schadensersatz. Alle Rechte vorbehalten, insbesondere für den Fall der Patenterteilung oder GM-Eintragung.

Editor: Müller O.	17-Dec-97	Basic SW Inputs and Outputs	HMC_V6
Version: a 153589 from 18.12.97		657765.49.02	
File: CHAP_2.DOC	650H0000	Sourcefile:07200J01.00A	Page 64 / 98

1.2.5 Acquisition of vehicle speed

1.2.5.1 Basic software

Output data:

Name	Mode	Hex. limits	Phys. limits	Resol.	Unit
VS_MES	-	0..FF FFH	0..65535	1	p/s
Pulses per second measured for VS-calculation					

FUNCTION DESCRIPTION:

Vehicle speed signal from ABS / TCS ECU or from inductive wheel sensor
(CONF_VS = 1 or 2)

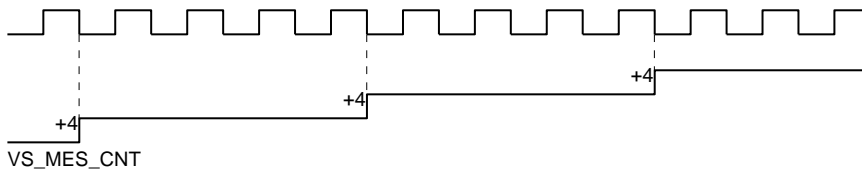

Vehicle speed signal from gearbox
(CONF_VS = 0)

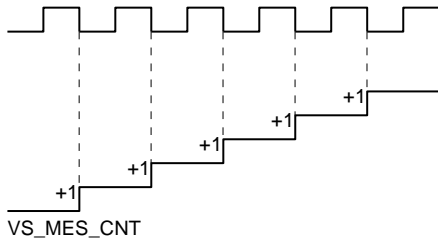

Formula section:

Application recurrence: 1sec.

$$VS_MES = VS_MES_CNT - VS_MES_CNT_PREV$$

$$VS_MES_CNT_PREV = VS_PULSE_CNT$$

Proprietary data, company confidential. All rights reserved.
 Contit a titre de secret d'entreprise. Tous droits réservés.
 Comunicado como segredo empresarial. Reservados todos os direitos.
 Confidado como secreto industrial. Nos reservamos todos los derechos.

Weitergabe sowie Vervielfältigung dieser Unterlage, Verwertung und Mitteilung ihres Inhalts nicht gestattet, soweit nicht ausdrücklich zugestanden. Zuwiderhandlungen verpflichten zu Schadensersatz. Alle Rechte vorbehalten, insbesondere für den Fall der Patenterteilung oder GM-Entragung.

Editor: Müller O.	17-Dec-97	Basic SW Inputs and Outputs	HMC_V6
Version: a 153589 from 18.12.97		657765.49.02	
File: CHAP_2.DOC	650H0000	Sourcefile:07200L01.00A	Page 65 / 98

2 Actuation of Outputs

2.1 Logic Outputs

Input data:

L_IM_SAV	LV_IM_RLY_FAN_L	LV_IM_RLY_FAN_H	LV_IM_RLY_SAP
LV_IM_SOV	LV_IM_RLY_EFP	LV_IM_RLY_ACCOUT	LV_IM_MIL
LV_IM_RLY_MAIN	LV_IM_PWL	L_IM_VIC	

2.1.1 List of direct logic Outputs

Name	Port - Channel	Logic state	Initialization
L_PIN_SAV	2 - 12	Negative Logic	1
L_PIN_SOV	4 - 7	Negative Logic	1
L_PIN_KNK_WIN_MES	6 - 5	*	1
L_PIN_RLY_MAIN	6 - 6	Negative Logic	0
L_PIN_SET	8 - 5	*	1
L_PIN_VIM	?	?	?
L_PIN_PWL	8 - 7	*	1

* : ECU Internal Signal

Proprietary data, company confidential. All rights reserved.
 Contit a titre de secret d'entreprise. Tous droits réservés.
 Comunicado como secreto empresarial. Reservados todos os direitos.
 Confidado como secreto industrial. Nos reservamos todos los derechos.

Weitergabe sowie Vervielfältigung dieser Unterlage, Verwertung und Mitteilung ihres Inhalts nicht gestattet, soweit nicht ausdrücklich zugestanden. Zuwiderhandlungen verpflichten zu Schadensersatz. Alle Rechte vorbehalten, insbesondere für den Fall der Patenterteilung oder GM-Enttragung.

Editor: Müller O.	17-Dec-97	Basic SW Inputs and Outputs	HMC_V6
Version: a 153589 from 18.12.97		657765.49.02	
File: CHAP_2.DOC	650H0000	Sourcefile:07200T01.00A	Page 66 / 98

2.1.2 List of logic Outputs via Octal Driver

Name	Channel	Logic state	Initialization
L_SHAD_RLY_FAN_L	2	Negative Logic	1
L_SHAD_RLY_SAP	3	Negative Logic	1
L_SHAD_RLY_ACCOUT	4	Negative Logic	1
L_SHAD_RLY_EFP	5	Negative Logic	1
L_SHAD_RLY_FAN_H	6	Negative Logic	1
L_SHAD_MIL	7	Negative Logic	1

Data definition

Name	Definition
LV_IM_RLY_FAN_L	Cooling Fan Relay for Low speed.
LV_IM_MIL	Malfunction Indicator Light - Flashing code.
LV_IM_RLY_ACCOUT	Air Conditioning Compressor Relay.
LV_IM_RLY_EFP	Electric Fuel Pump Relay.
LV_IM_RLY_FAN_H	Cooling Fan Relay for High speed.
LV_IM_RLY_SAP	Secondary Air Pump Relay.

Proprietary data, company confidential. All rights reserved.
 Contient des informations confidentielles. Tous droits réservés.
 Comunicado como secreto empresarial. Reservados todos os direitos.
 Confidado como secreto industrial. Nos reservamos todos los derechos.

Weitergabe sowie Vervielfältigung dieser Unterlage, Verwertung und Mitteilung ihres Inhalts ist gestattet, soweit nicht ausdrücklich zugestanden. Zuwiderhandlungen verpflichten zu Schadensersatz. Alle Rechte vorbehalten, insbesondere für den Fall der Patenterteilung oder GM-Entragung.

Editor: Müller O.	17-Dec-97	Basic SW Inputs and Outputs	HMC_V6
Version: a 153589 from 18.12.97		657765.49.02	
File: CHAP_2.DOC	650H0000	Sourcefile:07200T01.00A	Page 67 / 98

2.2 PWM Outputs

Input data:

ISAPWM	EGRPWM	LSH_UP_1PWM	LSH_UP_2PWM
CPPWM	LSH_DOWN_1PWM	LSH_DOWN_2PWM	KNKPWM
LV_CT	LV_TPS_ERR	LV_TPS_PLAUS_ERR	

FUNCTION DESCRIPTION:

General information:

PWM management principle :

“ Positive “ PWM :

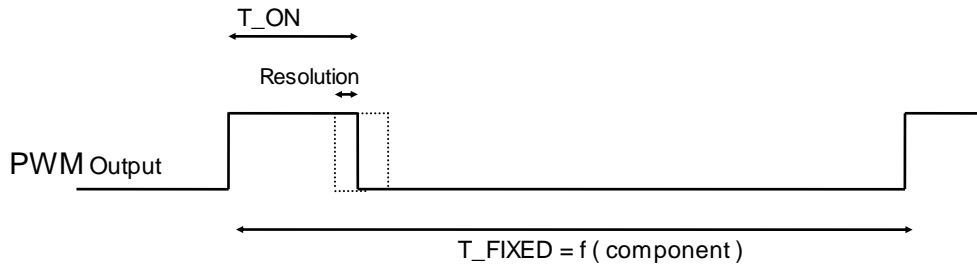

Duty cycle = T_{ON} / T_{FIXED}

“ Negative “ PWM :

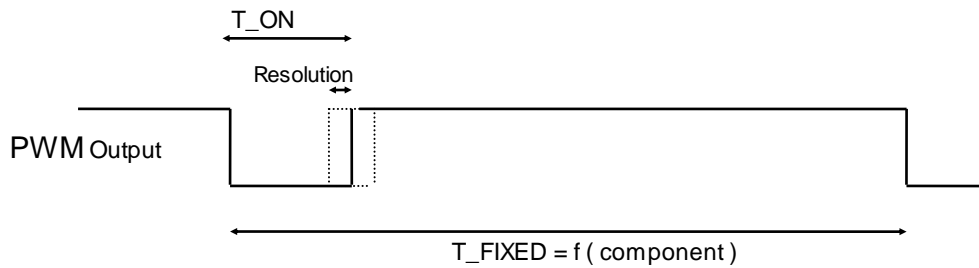

Duty cycle = T_{ON} / T_{FIXED}

Proprietary data, company confidential. All rights reserved. Contine a titre de secret d'entreprise. Tous droits réservés. Comunicado como segredo empresarial. Reservados todos os direitos. Confidado como secreto industrial. Nos reservamos todos los derechos.

Weitergabe sowie Vervielfältigung dieser Unterlage, Verwertung und Mitteilung ihres Inhalts nicht gestattet, soweit nicht ausdrücklich zugestanden. Zuwiderhandlungen verpflichten zu Schadensersatz. Alle Rechte vorbehalten, insbesondere für den Fall der Patenterteilung oder GM-Entragung.

List of PWM Outputs

PWM Output Name T On	Frequency (Hz)	Attached Component	Updating of Duty Cycle (ms)	Range of Duty Cycle (%)	PWM State
ISAPWM	100	BOSCH ZWD3 - 2	10	3,5 - 96,5	Negative
EGRPWM	50	H.E.I.	100	0 - 100	Negative
TPPWM	100	T.C.U.	10	5 - 91	Negative
LSH_UP_1PWM	10	TiO2 NTK	by applicative value	2,3 - 97,3	Positive
LSH_UP_2PWM	10	TiO2 NTK	by applicative value	2,3 - 97,3	Positive
LSH_DOWN_1PWM	10	TiO2 NTK	by applicative value	2,3 - 97,3	Positive
LSH_DOWN_2PWM	10	TiO2 NTK	by applicative value	2,3 - 97,3	Positive
CPPWM	20	BOSCH TEV2	100	0 - 100	Negative
KNKPWM	5000	KONGWHA	720 °CRK	0 - 100	Positive

Data definition

Name	Definition
ISAPWM	Double coil idle speed valve PWM output.
EGRPWM	Exhaust gas recirculation PWM output.
LSH_UP_1PWM	A/F regulation O2 sensor (Bank 1) PWM output.
LSH_UP_2PWM	A/F regulation O2 sensor (Bank 2) PWM output.
LSH_DOWN_1PWM	Catalyst diagnosis O2 sensor (Bank1) PWM output.
LSH_DOWN_2PWM	Catalyst diagnosis O2 sensor (Bank2) PWM output.
CPPWM	Canister purge valve PWM output.
KNKPWM	Knock amplification PWM output.

Proprietary data, company confidential. All rights reserved.
 Contine a titre de secret d'entreprise. Tous droits réservés.
 Comunicado como segredo empresarial. Reservados todos os direitos.
 Confidado como secreto industrial. Nos reservamos todos los derechos.

Weitergabe sowie Vervielfältigung dieser Unterlage, Verwertung und Mitteilung ihres Inhalts nicht gestattet, soweit nicht ausdrücklich zugestanden. Zuwiderhandlungen verpflichten zu Schadenersatz. Alle Rechte vorbehalten, insbesondere für den Fall der Patenterteilung oder GM-Entragung.

Editor: Müller O.	17-Dec-97	Basic SW Inputs and Outputs	HMC_V6
Version: a 153589 from 18.12.97		657765.49.02	
File: CHAP_2.DOC	650H0000	Sourcefile:07200V01.00B	Page 69 / 98

Calculation of TPPWM:

Closed throttle: 5% TPPWM
 C_TPS_WOT_TPS_PWM: 91% TPPWM
 LV_TPS_ERR = 1
 or
 LV_TPS_PLAUS_ERR = 1: 0% TPPWM (Error on TPS)

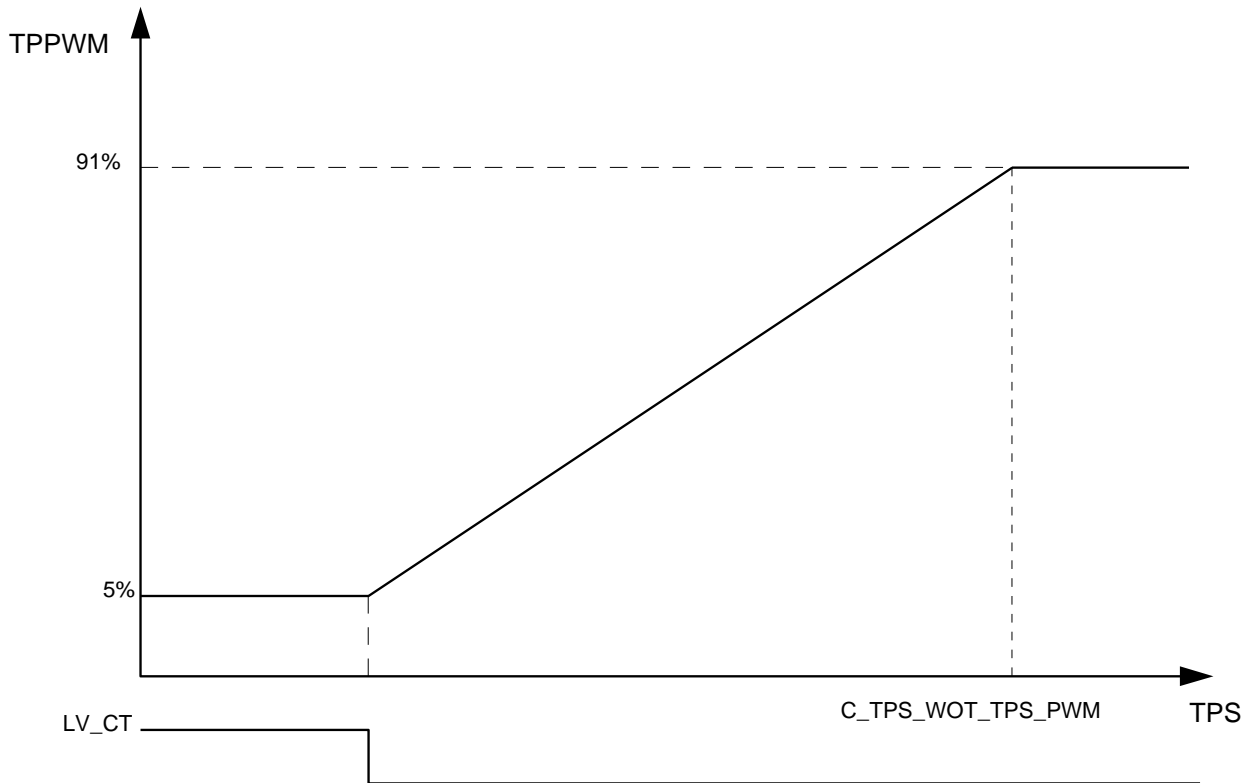

Calibration data:

Name	Dim	Hex. limits	Phys. limits	Resol.	Unit
C_TPS_WOT_TPS_PWM	1	0...FFH	0...119,5	0,47	°TPS
Throttle angle which corresponds with 91% TPPWM					

Editor: Müller O.	17-Dec-97	Basic SW Inputs and Outputs		HMC_V6
Version: a 153589 from 18.12.97		657765.49.02		
File: CHAP_2.DOC	650H0000	Sourcefile:07200V01.00B		Page 70 / 98

Proprietary data, company confidential. All rights reserved.
 Contine a titre de secret d'entreprise. Tous droits réservés.
 Comunicado como segredo empresarial. Reservados todos os direitos.
 Confidado como secreto industrial. Nos reservamos todos los derechos.

Weitergabe sowie Vervielfältigung dieser Unterlage, Verwertung und Mitteilung ihres Inhalts nicht gestattet, soweit nicht ausdrücklich zugestanden. Zuwiderhandlungen verpflichten zu Schadensersatz. Alle Rechte vorbehalten, insbesondere für den Fall der Patenterteilung oder GM-Eintragung.

2.2.1 Fuel injection output

2.2.1.1 Basic software

Output data:

Name	Mode	Hex. limits	Phys. limits	Resol.	Unit
TI_[CYL]	V	0...FFFFH	0...262,14	4 µs	msec
Individual applied injection time.					
TI_SAM	V	0...FFFFH	0...262,14	4 µs	msec
Applied injection time updated each segment.					
L_PREV_STATE_IV_[CYL]	-	0...1H	0...1	1	-
Previous injection - Transition to cylinder re-start.					
LV_INH_TIPR	-	0...1H	0...1	1	-
Re-activation of first injection.					
FCO_SUM	-	0...FFFFFFFFH	0...1,72E10	4	µs
Accumulated injection time					

Input data:

TI_ADD_REAC_SCC_[CYL]	SOI	EOI	INH_SWI_IV
CRK_VALID_TEETH_CNT	TI_1	TI_2	LV_LOW_N
LV_RUN_ENG	TIPR	TI_ADD_DLY	TI_AS_[CYL]
LV_SYN_ENG	L_INH_IV_[CYL]	LV_TIPR_SEQ	LV_TIPR_EOI_STOP
NC_MAX_EOI	SOI_TIPR		

FUNCTION DESCRIPTION:

General information:

This specification is applicable for a 6 cylinders engine.

Transient engine operation :

- in case of acceleration, under transient engine operation, it is possible to continue an actual fuel injection (post injection without injector dead time TI_ADD_DLY) or to start a post injection (post injection with injector dead time TI_ADD_DLY).

- in case of deceleration, it is possible to finish an actual fuel injection.

Editor: Müller O.	17-Dec-97	Basic SW Inputs and Outputs	HMC_V6
Version: a 153589 from 18.12.97		657765.49.02	
File: CHAP_2.DOC	650H0000	Sourcefile:07200W01.00A	Page 71 / 98

2.2.1.1.1 First injection time programming

FUNCTION DESCRIPTION:

General information:

The first injection is taking into account the crankshaft and camshaft acquisitions which performed synchronisation event. It is performed in semi full group for both ignition banks.

If the camshaft level is **high**, the injection bank is nr.1.

If the camshaft level is **low**, the injection bank is nr.2.

The first injection applied to the corresponding cylinders is the value **TIPR** coming from applicative layer with the injector dead time **TI_ADD_DLY** added.

Remark : If the value **TIPR** coming from applicative layer is equal to **0**, then the injections coming after the first injection in semi full group (which are of course equal to **0**) are performed immediately (as soon as synchronisation is effective) with the cranking injection time value.

Formula section:

Condition for activation first injection time application (TIPR):

```

If                LV_RUN_ENG = 0 ⇒ 1
                    (engine running detected)
and               LV_LOW_N = 1
                    (low engine speed range detected)
and               LV_INH_TIPR = 0
                    (authorization of first injection re-activation)
then              LV_INH_TIPR = 1
and               First injection TIPR will be applied according to the timing description
                    below
else              LV_INH_TIPR = 1
and               fuel injection will start in sequential mode directly when crankschaft
                    synchronisation is performed (LV_SYN_ENG = 1 ⇒ 0)
                    using TI_[CYL]
    
```

Conditions to reset LV_INH_TIPR (reactivation of first injection TIPR)

```

If                (LV_IGK = 0 and LV_ES = 1)
or                system reset
then              LV_INH_TIPR = 0
    
```

Proprietary data, company confidential. All rights reserved. Contine a titre de secret d'entreprise. Tous droits réservés. Comunicado como segredo empresarial. Reservados todos os direitos. Confidado como secreto industrial. Nos reservamos todos los derechos.

Weitergabe sowie Vervielfältigung dieser Unterlage, Wertung und Mitteilung ihres Inhalts nicht gestattet, soweit nicht ausdrücklich zugestanden. Zuwiderhandlungen verpflichten zu Schadenersatz. Alle Rechte vorbehalten, insbesondere für den Fall der Patenterteilung oder GM-Entragung

Editor: Müller O.	17-Dec-97	Basic SW Inputs and Outputs	HMC_V6
Version: a 153589 from 18.12.97		657765.49.02	
File: CHAP_2.DOC	650H0000	Sourcefile:07200W01.00A	Page 72 / 98

Description:

Proprietary data, company confidential. All rights reserved.
 Contine a titre de secret d'entreprise. Tous droits réservés.
 Comunicado como segredo empresarial. Reservados todos os direitos.
 Confidado como secreto industrial. Nos reservamos todos los derechos.

Weitergabe sowie Vervielfältigung dieser Unterlage, Verwertung und Mitteilung ihres Inhalts nicht gestattet, soweit nicht ausdrücklich zugestanden. Zuwiderhandlungen verpflichten zu Schadensersatz. Alle Rechte vorbehalten, insbesondere für den Fall der Patenterteilung oder GM-Entragung

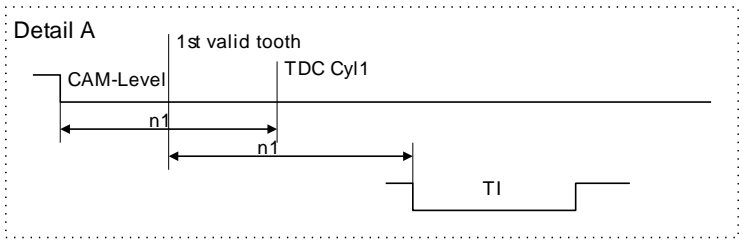
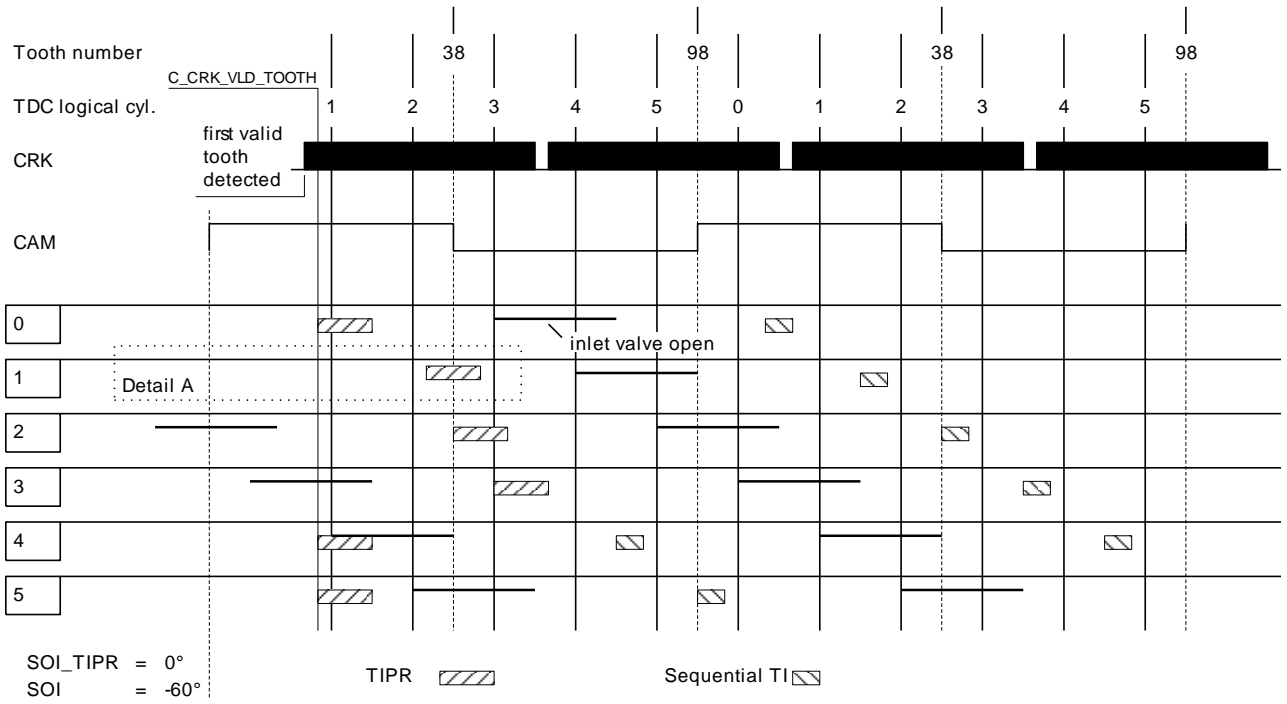

Editor: Müller O.	17-Dec-97	Basic SW Inputs and Outputs	HMC_V6
Version: a 153589 from 18.12.97		657765.49.02	
File: CHAP_2.DOC	650H0000	Sourcefile:07200W01.00A	Page 73 / 98

Proprietary data, company confidential. All rights reserved.
 Contine a titre de secret d'entreprise. Tous droits réservés.
 Comunicado como secreto empresarial. Reservados todos os direitos.
 Confidado como secreto industrial. Nos reservamos todos los derechos.

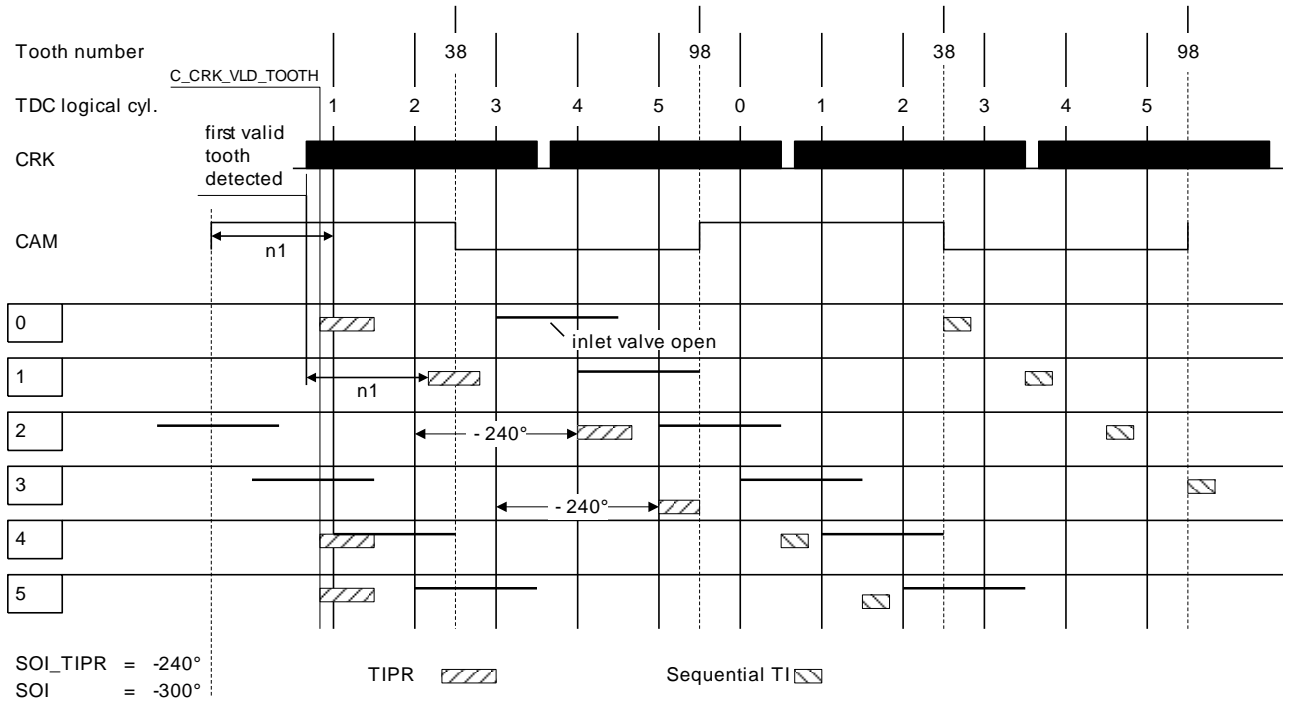

Weitergabe sowie Vervielfältigung dieser Unterlage, Verwertung und Mitteilung ihres Inhalts ist gestattet, soweit nicht ausdrücklich zugestanden. Zuwiderhandlungen verpflichten zu Schadensersatz. Alle Rechte vorbehalten, insbesondere für den Fall der Patenterteilung oder GM-Entragung.

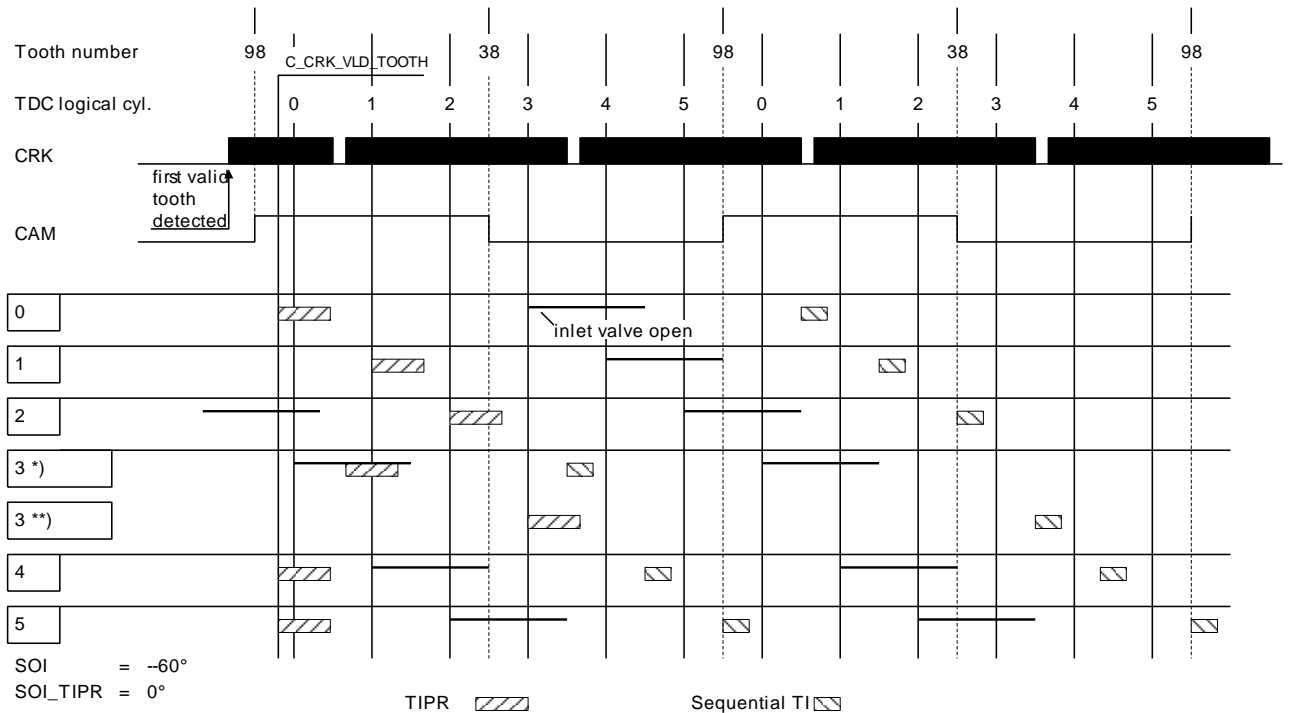

*) TIPR of cyl. 3 can be applied before BDC due to duration of TIPR in relation to current engine speed.

**) TIPR is applied at SOI_TIPR from the second revolution.

Remark: In case of low camshaft edge at start of cranking the cylinder groups are changed but the pre-injection is applied similar.

Editor: Müller O.	17-Dec-97	Basic SW Inputs and Outputs	HMC_V6
Version: a 153589 from 18.12.97		657765.49.02	
File: CHAP_2.DOC	650H0000	Sourcefile:07200W01.00A	Page 74 / 98

Sequential first injection:

If LV_TIPR_SEQ = 1
then the first injection is carried out as follows:

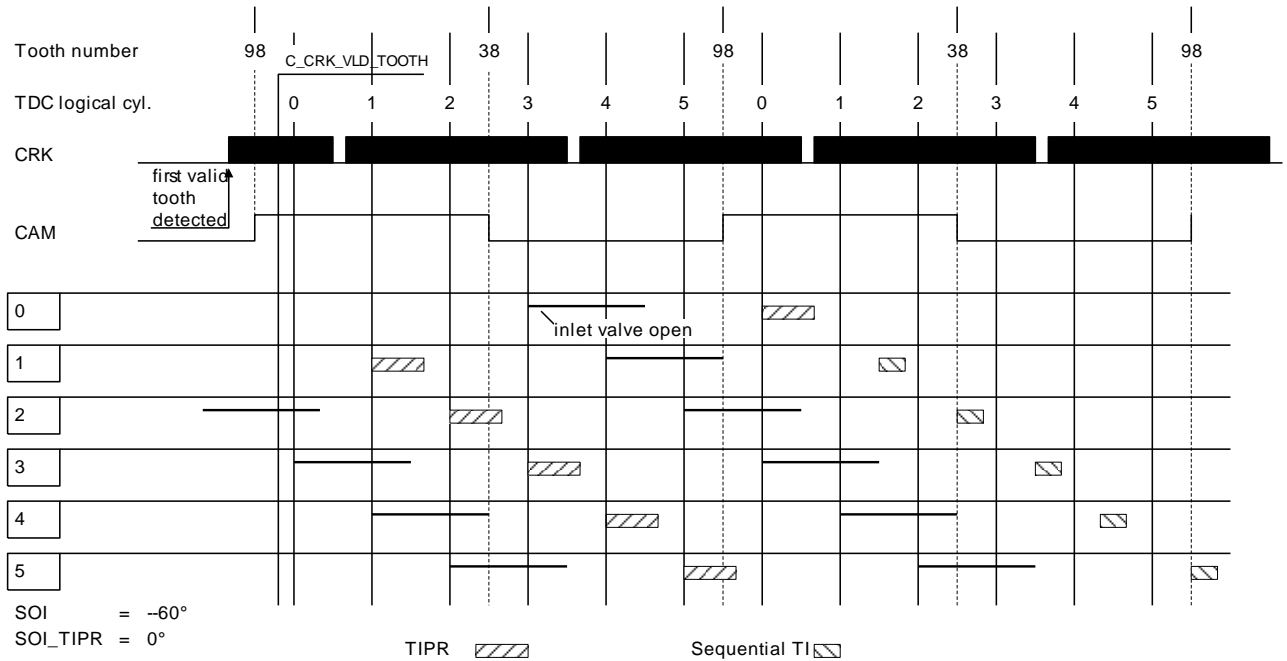

Proprietary data, company confidential. All rights reserved. Contine a titre de secret d'entreprise. Tous droits réservés. Comunicado como segredo empresarial. Reservados todos os direitos. Confidado como secreto industrial. Nos reservamos todos los derechos.

Weitergabe sowie Vervielfältigung dieser Unterlage, Verwertung und Mitteilung ihres Inhalts nicht gestattet, soweit nicht ausdrücklich zugestanden. Zuwiderhandlungen verpflichten zu Schadensersatz. Alle Rechte vorbehalten, insbesondere für den Fall der Patenterteilung oder GM-Eintragung.

Editor: Müller O.	17-Dec-97	Basic SW Inputs and Outputs	HMC_V6
Version: a 153589 from 18.12.97		657765.49.02	
File: CHAP_2.DOC	650H0000	Sourcefile:07200W01.00A	Page 75 / 98

First injection termination at NC_MAX_EOI

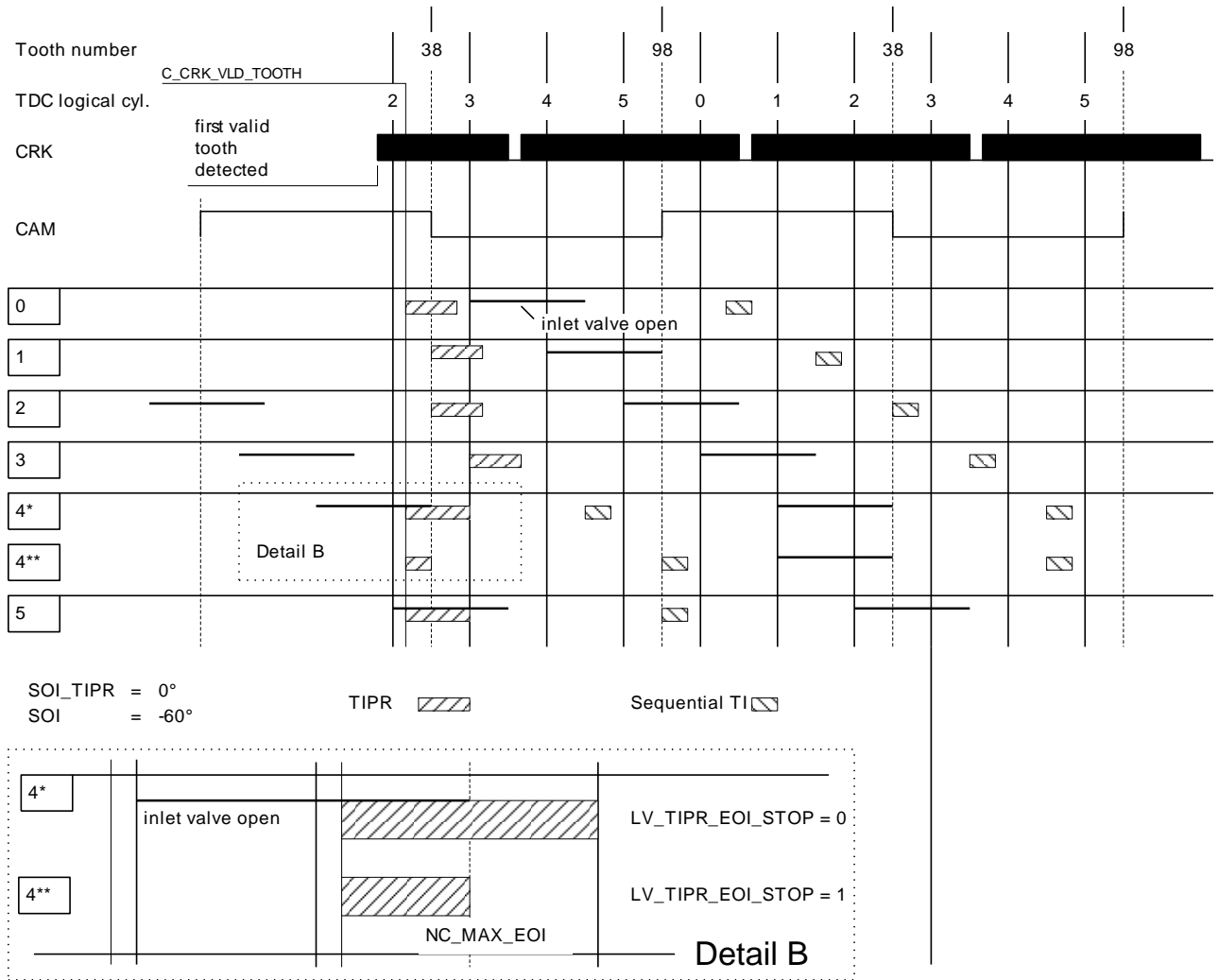

Proprietary data, company confidential. All rights reserved. Contine a titre de secret d'entreprise. Tous droits réservés. Comunicado como segredo empresarial. Reservados todos os direitos. Confidado como secreto industrial. Nos reservamos todos los derechos.

Weitergabe sowie Vervielfältigung dieser Unterlage, Wertung und Mitteilung ihres Inhalts nicht gestattet, soweit nicht ausdrücklich zugestanden. Zuwiderhandlungen verpflichten zu Schadensersatz. Alle Rechte vorbehalten, insbesondere für den Fall der Patenterteilung oder GM-Entragung.

2.2.1.1.2 Injection phase programming SOI (Start) and EOI (End)

FUNCTION DESCRIPTION:

General information:

Since the start of injection cycle (180 °CRK before TDC), the opening injection phase has been updated with a segment recurrence until the injector would be opened.

Editor: Müller O.	17-Dec-97	Basic SW Inputs and Outputs	HMC_V6
Version: a 153589 from 18.12.97		657765.49.02	
File: CHAP_2.DOC	650H0000	Sourcefile:07200W01.00A	Page 76 / 98

Formula section:

- Range description for SOI and EOI :

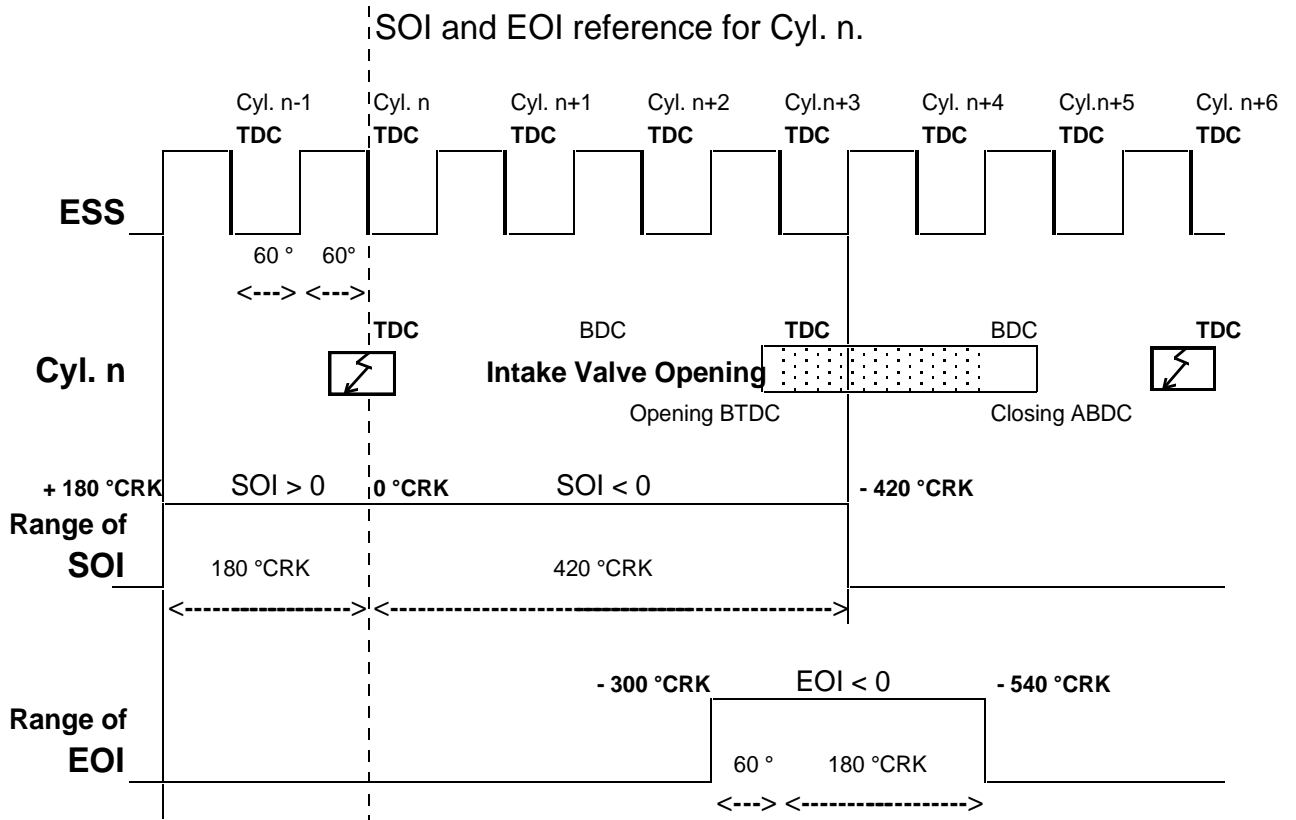

Proprietary data, company confidential. All rights reserved. Contit a titre de secret d'entreprise. Tous droits réservés. Comunicado como segredo empresarial. Reservados todos os direitos. Confidado como secreto industrial. Nos reservamos todos los derechos.

Weitergabe sowie Vervielfältigung dieser Unterlage, Verwertung und Mitteilung ihres Inhalts nicht gestattet, soweit nicht ausdrücklich zugestanden. Zuwiderhandlungen verpflichten zu Schadensersatz. Alle Rechte vorbehalten, insbesondere für den Fall der Patenterteilung oder GM-Entragung.

Editor: Müller O.	17-Dec-97	Basic SW Inputs and Outputs	HMC_V6
Version: a 153589 from 18.12.97		657765.49.02	
File: CHAP_2.DOC	650H0000	Sourcefile:07200W01.00A	Page 77 / 98

- Injection cycle description :

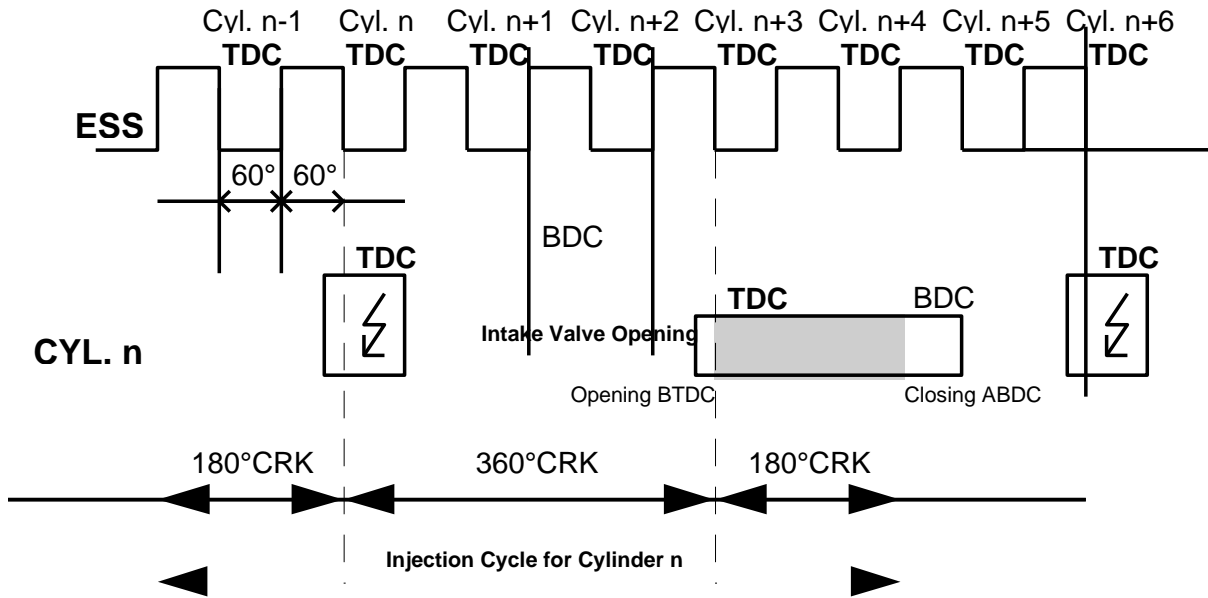

Proprietary data, company confidential. All rights reserved. Contine a titre de secret d'entreprise. Tous droits réservés. Comunicado como segredo empresarial. Reservados todos os direitos. Confidado como secreto industrial. Nos reservamos todos los derechos.

- Injection time applied :

At the end of injection (EOI), the injector is shut-off and the next opening injection phase (SOI) is programmed.

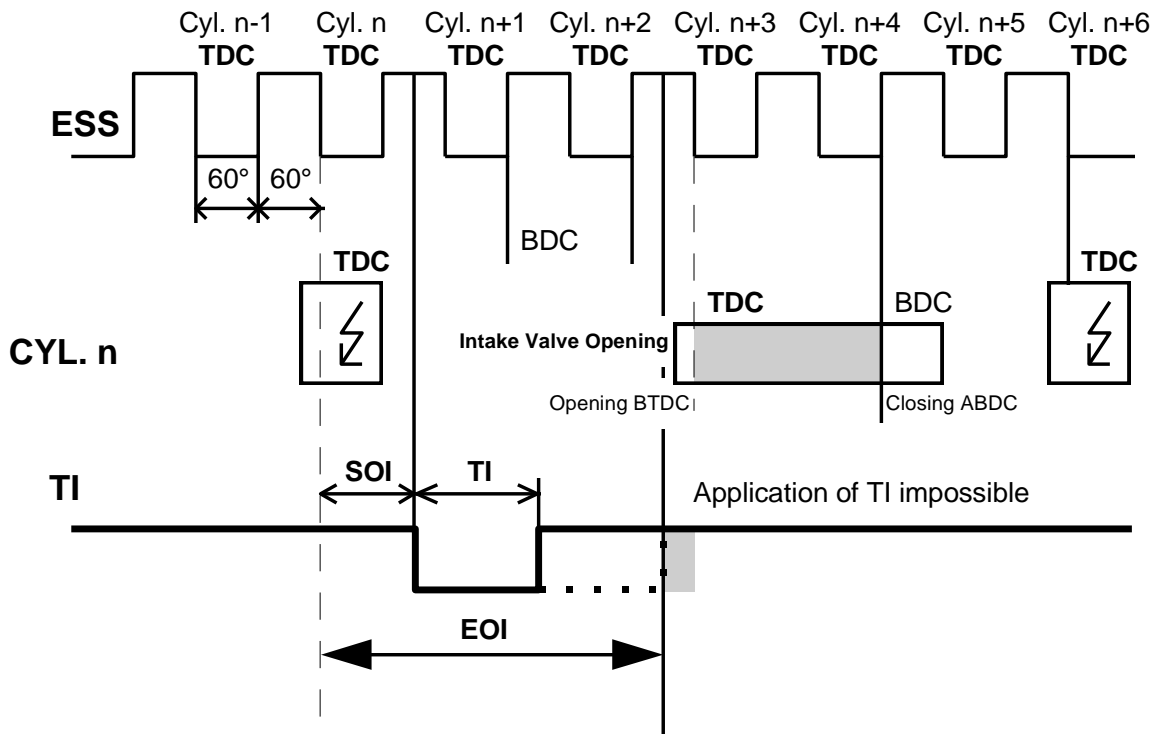

Weitergabe sowie Vervielfältigung dieser Unterlage, Verwertung und Mitteilung ihres Inhalts nicht gestattet, soweit nicht ausdrücklich zugestanden. Zuwiderhandlungen verpflichten zu Schadenersatz. Alle Rechte vorbehalten, insbesondere für den Fall der Patenterteilung oder GM-Enttragung.

Editor: Müller O.	17-Dec-97	Basic SW Inputs and Outputs	HMC_V6
Version: a 153589 from 18.12.97		657765.49.02	
File: CHAP_2.DOC	650H0000	Sourcefile:07200W01.00A	Page 78 / 98

2.2.1.1.3 Fuel shut-off

2.2.1.1.3.1 Fuel shut-off pattern INH_SWI_IV

FUNCTION DESCRIPTION:

General information:

The pattern is scanned from MSB to LSB and the bits are applied to the corresponding injection following the injection order.

For **Bit = 1**, injection is inhibited.

The length of the pattern must be changeable in software from number of cylinders (minimum) to NC_INI_INH_SWI_IV_SHIFT_NR (maximum). Every pattern starts with an inhibition of injection. The pattern are cyclically repeated.

According transient conditions, even in case with start of injection in advance, the following pattern must be scanned.

It is provided when SOI has been reached (beginning of injection). The value of the bit corresponding to the present pointer is checked to know if the present cylinder is allowed to receive injection. If this bit is set to 1, the injection is inhibited immediately and the corresponding injector remains inactive for the current injection cycle.

Description:

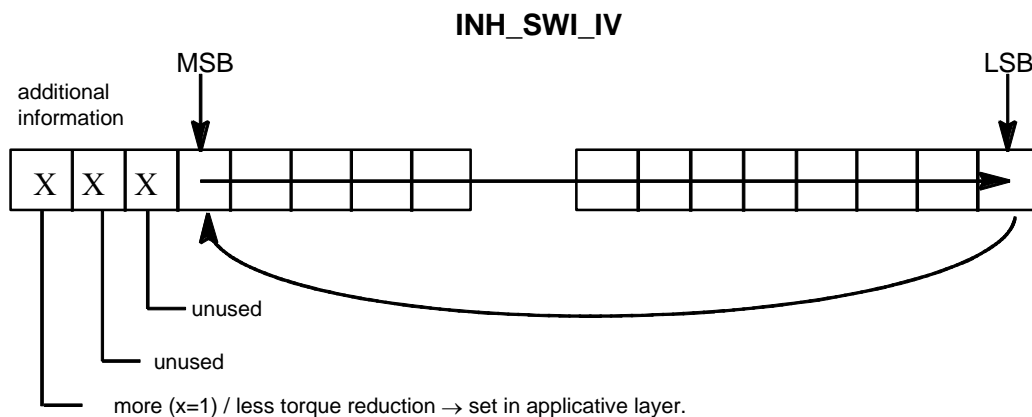

With torque reduction requested :

- for each new pattern, the pointer starts at MSB.

Without torque reduction requested :

- for each new pattern, the pointer continues at same position.

Editor: Müller O.	17-Dec-97	Basic SW Inputs and Outputs	HMC_V6
Version: a 153589 from 18.12.97		657765.49.02	
File: CHAP_2.DOC	650H0000	Sourcefile:07200W01.00A	Page 79 / 98

Proprietary data, company confidential. All rights reserved.
 Contient des informations confidentielles. Tous droits réservés.
 Comunicado como segredo empresarial. Reservados todos os direitos.
 Confidado como secreto industrial. Nos reservamos todos los derechos.

Weitergabe sowie Vervielfältigung dieser Unterlage, Verbreitung und Mitteilung ihres Inhalts nicht gestattet, soweit nicht ausdrücklich zugestanden. Zuwiderhandlungen verpflichten zu Schadensersatz. Alle Rechte vorbehalten, insbesondere für den Fall der Patenterteilung oder GM-Entragung.

2.2.1.1.3.2 Fuel shut-off with immediate re-activation versus L_INH_IV_[CYL] state

FUNCTION DESCRIPTION:

General information:

When the corresponding bit L_INH_IV_[CYL] is set to 1, the corresponding injector is immediately inhibited. The injector remains inhibited while the L_INH_IV_[CYL] is unchanged.

This function is used for trailing throttle fuel cut-off event and for emergency operation in case of misfire rate causing catalyst damage.

Description:

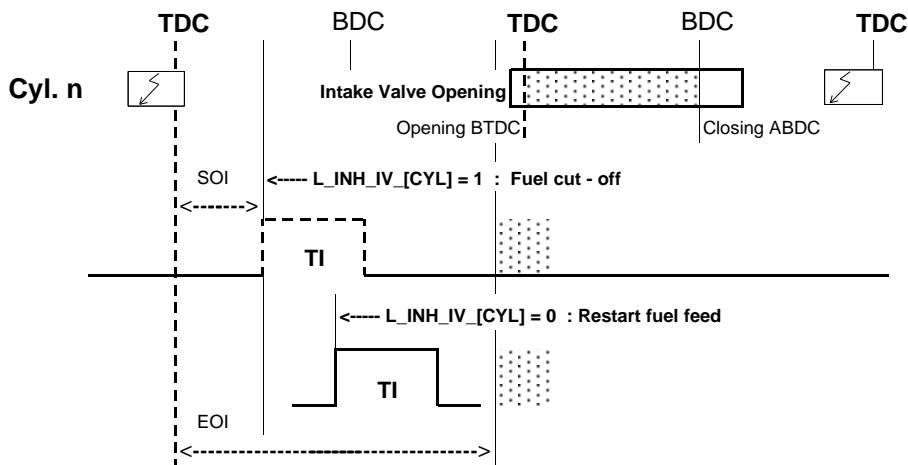

Proprietary data, company confidential. All rights reserved.
 Contient a titre de secret d'entreprise. Tous droits réservés.
 Comunicado como secreto empresarial. Reservados todos os direitos.
 Confidado como secreto industrial. Nos reservamos todos los derechos.

Weitergabe sowie Vervielfältigung dieser Unterlage, Verwertung und Mitteilung ihres Inhalts nicht gestattet, soweit nicht ausdrücklich zugestanden. Zuwiderhandlungen verpflichten zu Schadensersatz. Alle Rechte vorbehalten, insbesondere für den Fall der Patenterteilung oder GM-Eintragung.

Editor: Müller O.	17-Dec-97	Basic SW Inputs and Outputs	HMC_V6
Version: a 153589 from 18.12.97		657765.49.02	
File: CHAP_2.DOC	650H0000	Sourcefile:07200W01.00A	Page 80 / 98

2.2.1.1.3.3 Fuel injection information

FUNCTION DESCRIPTION:

General information:

The basic software update injection information 180 °CRK before TDC. It corresponds to the injection state from the previous injection cycle. Additionally the fuel quantity applied in the previous injection cycle is accumulated to FCO_SUM. $FCO_SUM = FCO_SUM + TI_ [CYL]$

Description:

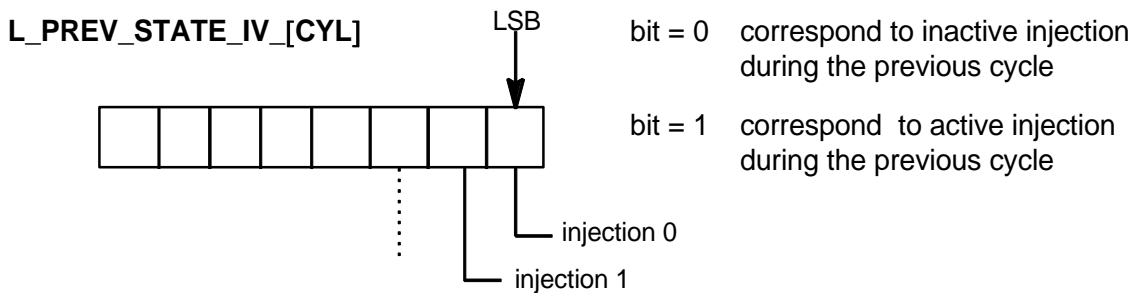

Each bit position corresponds to an injection.

2.2.1.1.4 Injection time programming

FUNCTION DESCRIPTION:

Formula section:

TI_[CYL] is the real opening duration of the injector.
On injection opening, the programmed injection time is :

$$TI_ [CYL] = (TI_ i + TI_ ADD_ REAC_ SCC_ [CYL]) * TI_ AS_ [CYL]$$

The injector control time is $TI_ [CYL] + TI_ ADD_ DLY$ with :

- TI_[CYL] : injector opening time applied to the corresponding injector
- TI_i : nominal injection time for bank i coming from applicative layer
- TI_ADD_REAC_SCC_[CYL] : injection time correction for individual cylinder restart fuel feed
- TI_AS_[CYL] : injection time tuned correction coming from applicative layer
- TI_ADD_DLY : injector dead time correction coming from applicative layer.

Editor: Müller O.	17-Dec-97	Basic SW Inputs and Outputs	HMC_V6
Version: a 153589 from 18.12.97		657765.49.02	
File: CHAP_2.DOC	650H0000	Sourcefile:07200W01.00A	Page 81 / 98

Proprietary data, company confidential. All rights reserved. Contine a titre de secret d'entreprise. Tous droits réservés. Comunicado como segredo empresarial. Reservados todos os direitos. Confidado como secreto industrial. Nos reservamos todos los derechos.

Weitergabe sowie Vervielfältigung dieser Unterlage, Verwertung und Mitteilung ihres Inhalts nicht gestattet, soweit nicht ausdrücklich zugestanden. Zuwiderhandlungen verpflichten zu Schadensersatz. Alle Rechte vorbehalten, insbesondere für den Fall der Patenterteilung oder GM-Entragung.

2.2.1.1.5 Fuel injection under transient engine operation

FUNCTION DESCRIPTION:

General information:

Under transient conditions it might appear that there is a significant change of the calculated injection time compared to the value which was valid when the injector was opened. Three cases are taken into account: refer to drawings below.

- **Injection time decrease:** as long as the injector is opened the injection time could be corrected.
- **Injection time increase while injector is open:** At the end of the regular injection time the additive injection time is applied without TI_ADD_DLY.
- **Injection time increase with injector already closed:** After application of the regular injection time the injector will be reopened including TI_ADD_DLY.

Remark: Additive fuel quantity will be applied only if there is an important enlargement (>NC_TIPO_MIN). NC_TIPO_MIN = 200µs

Proprietary data, company confidential. All rights reserved.
 Contient a titre de secret d'entreprise. Tous droits réservés.
 Comunicado como secreto empresarial. Reservados todos os direitos.
 Confidado como secreto industrial. Nos reservamos todos los derechos.

Weitergabe sowie Vervielfältigung dieser Unterlage, Verwertung und Mitteilung ihres Inhalts nicht gestattet, soweit nicht ausdrücklich zugestanden. Zuwiderhandlungen verpflichten zu Schadensersatz. Alle Rechte vorbehalten, insbesondere für den Fall der Patenterteilung oder GM-Enttragung.

Editor: Müller O.	17-Dec-97	Basic SW Inputs and Outputs	HMC_V6
Version: a 153589 from 18.12.97		657765.49.02	
File: CHAP_2.DOC	650H0000	Sourcefile:07200W01.00A	Page 82 / 98

Proprietary data, company confidential. All rights reserved. Contine a titre de secret d'entreprise. Tous droits réservés. Comunicado como segredo empresarial. Reservados todos os direitos. Confidado como secreto industrial. Nos reservamos todos los derechos.

Weitergabe sowie Vervielfältigung dieser Unterlage, Verwertung und Mitteilung ihres Inhalts nicht gestattet, soweit nicht ausdrücklich zugestanden. Zuwiderhandlungen verpflichten zu Schadensersatz. Alle Rechte vorbehalten, insbesondere für den Fall der Patenterteilung oder GM-Eintragung.

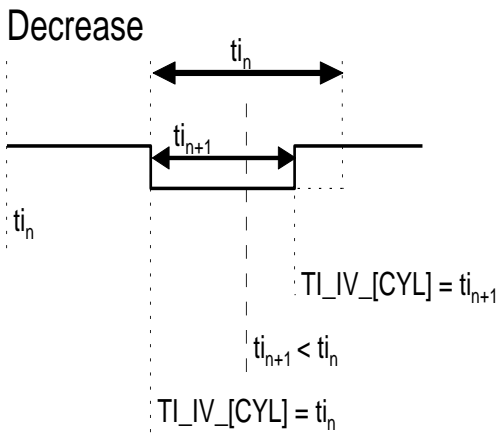
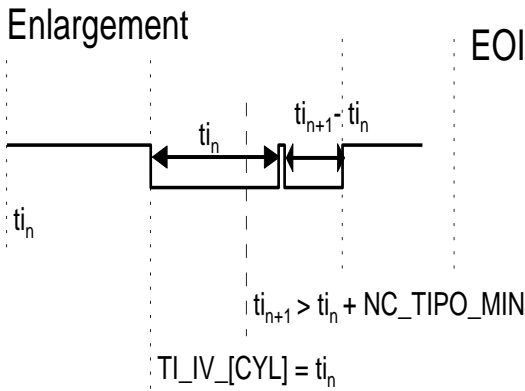
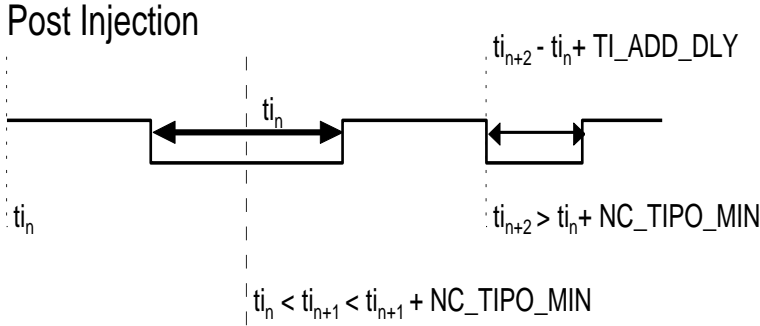

Editor: Müller O.	17-Dec-97	Basic SW Inputs and Outputs	HMC_V6
Version: a 153589 from 18.12.97		657765.49.02	
File: CHAP_2.DOC	650H0000	Sourcefile:07200W01.00A	Page 83 / 98

2.2.2 Spark advance and Dwell output

2.2.2.1 Basic software

Input data:

T_TOOTH	TD	TD_MPL	TD_MPL_DLY
IGA_IGC_[CYL]	LV_LOW_N	LV_MPL_ADV_ACT	

FUNCTION DESCRIPTION:

General information:

This function set the angular position of the Dwell time turn ON in order to have the time to set up the right current in the ignition coil.

The strategy respects dual output ignition coil depending on the current application.

With the beginning of the Dwell time, a time-out (Dwell “watchdog”) has to be initialized to ensure at each time a turn ON of the ignition coil.

2.2.2.1.1 Normal ignition and Dwell control (LV_LOW_N = 0 (Passive))

System meaning :

The calculation for the beginning of the Dwell time is triggered by initialization before any turn ON of each ignition coil.

The coil driver is turned ON at the interruption defined for beginning of Dwell time and turned OFF at IGA_IGC_[CYL] crankshaft position.

Description:

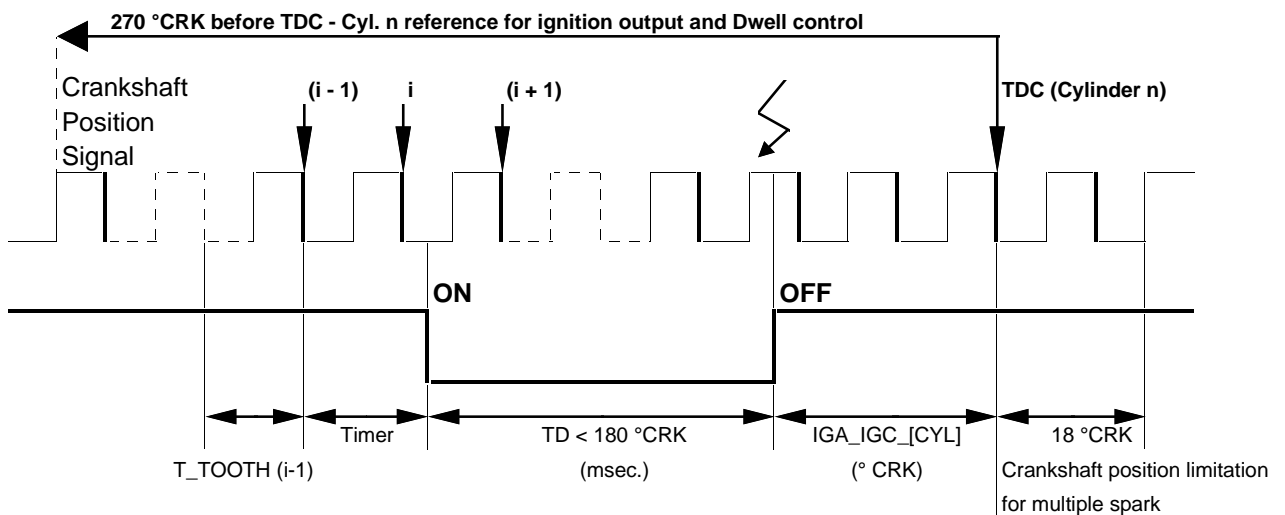

Remark :

The timer following T_TOOTH_{i-1} takes into account this value in order to reach the right crankshaft position to start the beginning of the Dwell time.

Editor: Müller O.	17-Dec-97	Basic SW Inputs and Outputs	HMC_V6
Version: a 153589 from 18.12.97		657765.49.02	
File: CHAP_2.DOC	650H0000	Sourcefile:07200X01.00A	Page 84 / 98

Proprietary data, company confidential. All rights reserved. Contient a titre de secret d'entreprise. Tous droits réservés. Comunicado como segredo empresarial. Reservados todos os direitos. Confidado como secreto industrial. Nos reservamos todos los derechos.

Weitergabe sowie Vervielfältigung dieser Unterlage, Verwertung und Mitteilung ihres Inhalts nicht gestattet, soweit nicht ausdrücklich zugestanden. Zuwiderhandlungen verpflichten zu Schadenersatz. Alle Rechte vorbehalten, insbesondere für den Fall der Patenterteilung oder GM-Entragung.

2.2.2.1.2 Dwell control in case of low engine speed (LV_LOW_N = 1 (Active))

System meaning :

In case of low engine speed (LV_LOW_N = 1 (Active)), beginning at the reference crankshaft position for the corresponding cylinder (270 °CRK before TDC), it is checked if the Dwell time has to be started within the next two teeth. In this case, the timer before beginning of Dwell time is started as defined previously.

2.2.2.1.3 Dwell time “watchdog”

System meaning :

When stalling, the calculated conduction time may be too large because of the reduction of engine speed, between conduction angle calculation and spark. A timer limits the resulting conduction time (ignition power stage protection against high current).

The Dwell “watchdog” time-out duration is defined as :
 $1,4 * TD$

The ignition output is turned OFF immediately before IGA_IGC_[CYL].

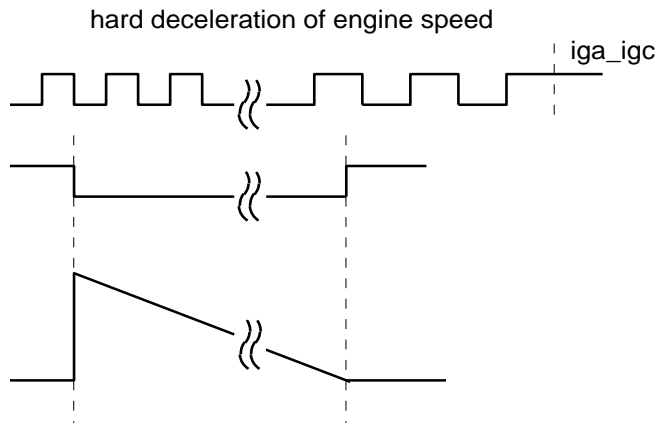
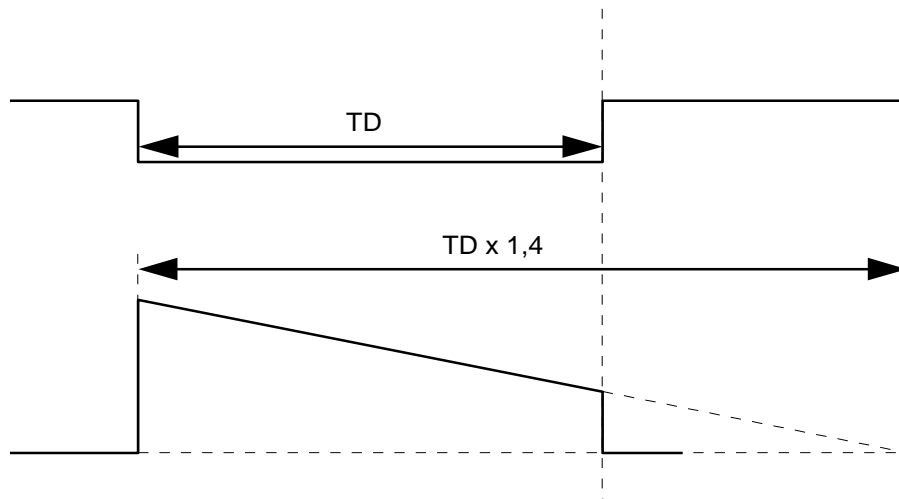

Proprietary data, company confidential. All rights reserved. Contine a titre de secret d'entreprise. Tous droits réservés. Comunicado como segredo empresarial. Reservados todos os direitos. Confidado como secreto industrial. Nos reservamos todos los derechos.

Weitergabe sowie Vervielfältigung dieser Unterlage, Verwertung und Mitteilung ihres Inhalts nicht gestattet, soweit nicht ausdrücklich zugestanden. Zuwiderhandlungen verpflichten zu Schadensersatz. Alle Rechte vorbehalten, insbesondere für den Fall der Patenterteilung oder GM-Eintragung.

Editor: Müller O.	17-Dec-97	Basic SW Inputs and Outputs	HMC_V6
Version: a 153589 from 18.12.97		657765.49.02	
File: CHAP_2.DOC	650H0000	Sourcefile:07200X01.00A	Page 85 / 98

2.2.2.1.4 Multiple spark

System meaning :

To improve the engine starting phase, the spark advance control can continue until the maximum crankshaft angle is reached (18 °CRK after TDC).

The Boolean LV_MPL_ADV_ACT from applicative layer controls the activation and the deactivation of multiple spark function.

The value TD_MPL determines the conduction time of the ignition coil and the time delay TD_MPL_DLY specifies a time-out when the ignition coil is turn ON for the next spark.

The duration of multiple spark advance is limited to 60 msec.

Description:

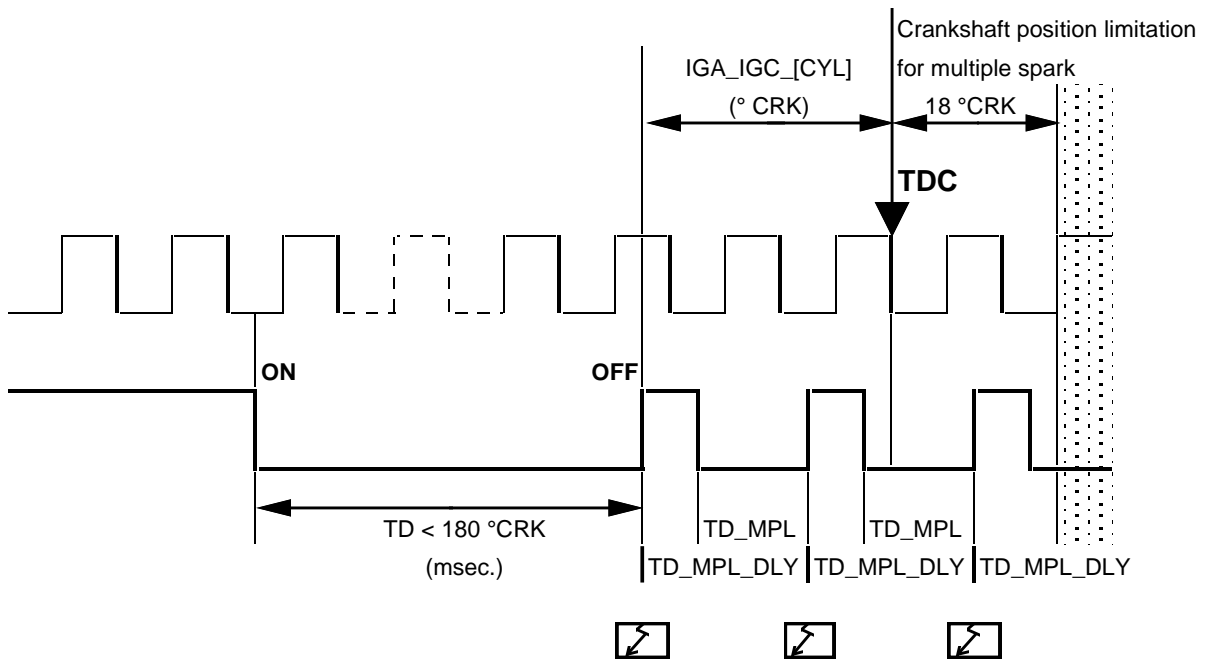

Proprietary data, company confidential. All rights reserved. Contine a titre de secret d'entreprise. Tous droits réservés. Comunicado como segredo empresarial. Reservados todos os direitos. Confidado como secreto industrial. Nos reservamos todos los derechos.

Weitergabe sowie Vervielfältigung dieser Unterlage, Verwertung und Mitteilung ihres Inhalts nicht gestattet, soweit nicht ausdrücklich zugestanden. Zuwiderhandlungen verpflichten zu Schadensersatz. Alle Rechte vorbehalten, insbesondere für den Fall der Patenterteilung oder GM-Eintragung.

Editor: Müller O.	17-Dec-97	Basic SW Inputs and Outputs	HMC_V6
Version: a 153589 from 18.12.97		657765.49.02	
File: CHAP_2.DOC	650H0000	Sourcefile:07200X01.00A	Page 86 / 98

2.2.2.2 Applicative software

2.2.2.2.1 Dwell time control

Output data:

Name	Mode	Hex. limits	Phys. limits	Resol.	Unit
TD	V	0...FFFFH	0...262,14	4 μs	msec
Dwell time.					

Input data:

VB	N_32		
----	------	--	--

FUNCTION DESCRIPTION:

General information:

The Dwell time open-loop control value is calculated versus battery voltage and engine speed.

Application recurrence : **10 msec.**

Formula section:

$TD = IP_TD_VB_N_32 + C_TD_AS$

Calibration data:

Name	Dim	Hex. limits	Phys. limits	Resol.	Unit
IP_TD_VB_N_32	8 x 5	0...1D4CH	0...30	4 μs	msec
Dwell time.					
C_TD_AS	1	80...7FH	-8,192...8,128	64 μs	msec
Dwell time application system.					

Proprietary data, company confidential. All rights reserved. Contient des informations confidentielles de la Siemens. Toute réimpression ou utilisation non autorisée sans la permission écrite de la Siemens est formellement interdite.

Weitergabe sowie Vervielfältigung dieser Unterlage, Verwertung und Mitteilung ihres Inhalts ist gestattet, soweit nicht ausdrücklich zugestanden. Zuwiderhandlungen verpflichten zu Schadensersatz. Alle Rechte vorbehalten, insbesondere für den Fall der Patenterteilung oder GM-Entragung.

2.2.2.2.2 Multiple spark

Output data:

Name	Mode	Hex. limits	Phys. limits	Resol.	Unit
TD_MPL	-	0...FFFFH	0...262,14	4 μs	msec
Dwell time for multiple spark.					
TD_MPL_DLY	-	0...FFH	0...1,02	4 μs	msec
Duration between two ignition coil loading phases.					
LV_MPL_ADV_ACT	V	0...01H	0...1	1	-
Boolean information for multiple spark processing - (Passive / Active).					

Input data:

VB	N_32	TCO	LV_VB_JUMP
LV_ES	LV_ST		

FUNCTION DESCRIPTION:

General information:

At start and following application conditions, the ignition is controlled by means of multiple spark.

After the adjustable combustion period C_TD_T_MPL, the ignition coil is loaded with a specific Dwell time IP_TD_MPL__VB related to multiple spark.

The multiple sparks are stopped **18 °CRK** after TDC.

Formula section:

```

If                engine stopped active (LV_ES)
                or   engine start active (LV_ST)
                and  TCO < C_TCO_MAX_MPL
                and  LV_VB_JUMP = 0 (Passive)
then              LV_MPL_ADV_ACT = 1 (Active)
                and  TD_MPL = IP_TD_MPL__VB
                and  TD_MPL_DLY = C_TD_T_MPL
else              LV_MPL_ADV_ACT = 0 (Passive)
Endif.
    
```

Editor: Müller O.	17-Dec-97	Basic SW Inputs and Outputs	HMC_V6
Version: a 153589 from 18.12.97		657765.49.02	
File: CHAP_2.DOC	650H0000	Sourcefile:07200X01.00A	Page 88 / 98

Calibration data:

Name	Dim	Hex. limits	Phys. limits	Resol.	Unit
IP_TD_MPL_VB	8	0...1D4CH	0...30	4 µs	msec
Dwell time relative to multiple spark.					
C_TD_T_MPL	1	0...FFH	0...1,02	4 µs	msec
Duration between two ignition coil loading phases.					
C_TCO_MAX_MPL	1	0...FFH	-48...142,5	0,75	°C
Coolant temperature threshold at start for multiple spark application.					

Proprietary data, company confidential. All rights reserved.
 Contitue a titre de secret d'entreprise. Tous droits réservés.
 Comunicado como segredo empresarial. Reservados todos os direitos.
 Confidado como secreto industrial. Nos reservamos todos los derechos.

Weitergabe sowie Vervielfältigung dieser Unterlage, Verwertung und Mitteilung ihres Inhalts nicht gestattet, soweit nicht ausdrücklich zugestanden. Zuwiderhandlungen verpflichten zu Schadensersatz. Alle Rechte vorbehalten, insbesondere für den Fall der Patenterteilung oder GM-Entragung.

Editor: Müller O.	17-Dec-97	Basic SW Inputs and Outputs	HMC_V6
Version: a 153589 from 18.12.97		657765.49.02	
File: CHAP_2.DOC	650H0000	Sourcefile:07200X01.00A	Page 89 / 98

2.2.3 Fuel consumption signal output FCO

2.2.3.1 Basic software

Input data:



FUNCTION DESCRIPTION:

General information:

The specification is applicable for a 6 cylinders engine.

The ECU generates a fuel consumption output signal (FCO) to be dispatched to other ECUs (Transmission Control Unit, Dashboard ...).

The fuel consumption output signal is activated once per crankshaft revolution and the active time duration T_FCO is derived from the calculated injection time.

Initialisation :

The output signal is initialised with a high logic state (1).

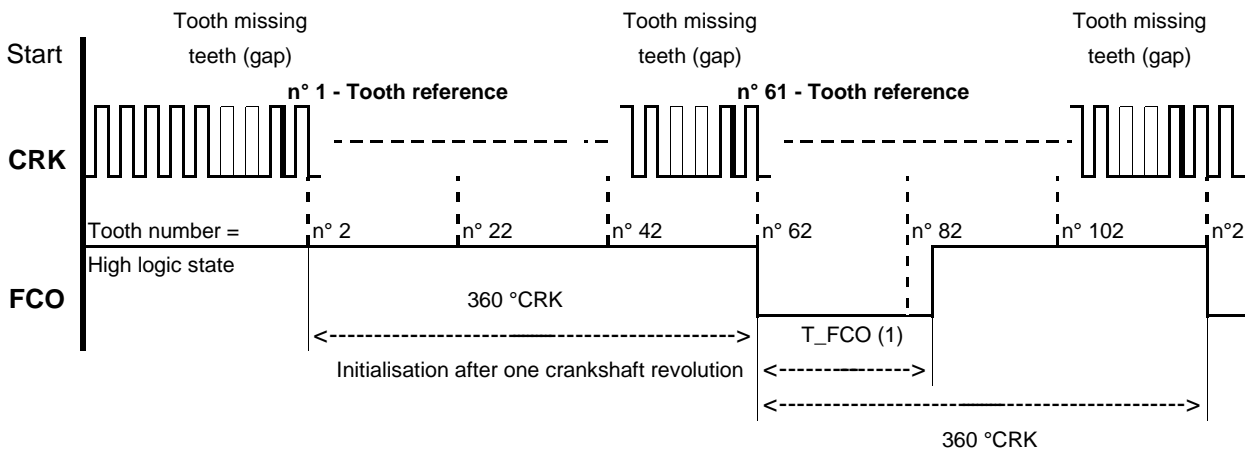

Proprietary data, company confidential. All rights reserved. Contient a titre de secret d'entreprise. Tous droits réservés. Comunicado como segredo empresarial. Reservados todos os direitos. Confidado como secreto industrial. Nos reservamos todos los derechos.

Weitergabe sowie Vervielfältigung dieser Unterlage, Verwertung und Mitteilung ihres Inhalts nicht gestattet, soweit nicht ausdrücklich zugestanden. Zuwiderhandlungen verpflichten zu Schadenersatz. Alle Rechte vorbehalten, insbesondere für den Fall der Patenterteilung oder GM-Entragung.

Editor: Müller O.	17-Dec-97	Basic SW Inputs and Outputs	HMC_V6
Version: a 153589 from 18.12.97		657765.49.02	
File: CHAP_2.DOC	650H0000	Sourcefile:07201001.00A	Page 90 / 98

Formula section:

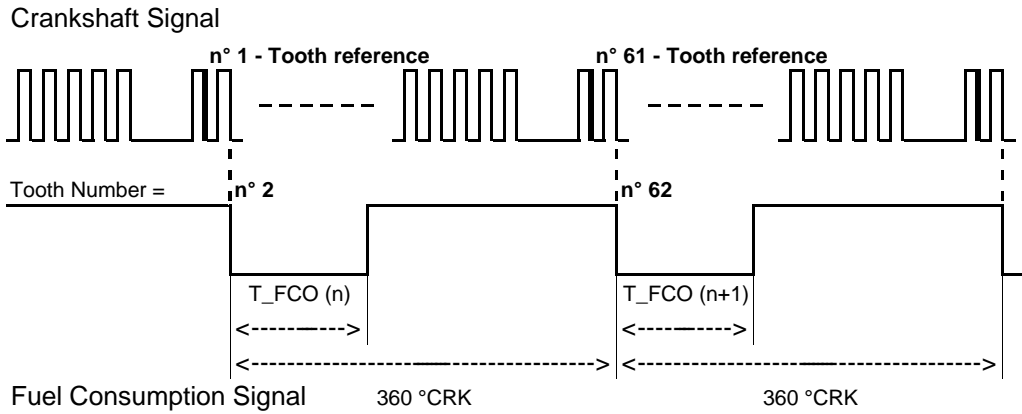

Remark :

- If $T_FCO_i = 0$ then the fuel consumption signal FCO remains with a high logic state.
- In case of overlapping ($T_FCO_i > T_REV$: corresponding segment period), T_FCO_i is interrupted and T_FCO_{i+1} is started.

Proprietary data, company confidential. All rights reserved.
 Contit a titre de secret d'entreprise. Tous droits réservés.
 Comunicado como secreto empresarial. Reservados todos os direitos.
 Confidado como secreto industrial. Nos reservamos todos los derechos.

Weitergabe sowie Vervielfältigung dieser Unterlage, Verwertung und Mitteilung ihres Inhalts nicht gestattet, soweit nicht ausdrücklich zugestanden. Zuwiderhandlungen verpflichten zu Schadensersatz. Alle Rechte vorbehalten, insbesondere für den Fall der Patenterteilung oder GM-Enttragung.

Editor: Müller O.	17-Dec-97	Basic SW Inputs and Outputs	HMC_V6
Version: a 153589 from 18.12.97		657765.49.02	
File: CHAP_2.DOC	650H0000	Sourcefile:07201001.00A	Page 91 / 98

2.2.3.2 Applicative software

Output data:

Name	Mode	Hex. limits	Phys. limits	Resol.	Unit
T_FCO	-	0...FFFFH	0...262	4 µs	msec / rev.
Active time duration for fuel consumption signal output.					

Input data:

FCO_SUM		
---------	--	--

FUNCTION DESCRIPTION:

General information:

The active time duration T_FCO is calculated once per crankshaft revolution.

T_FCO is equal to the injected fuel quantity during the last crankshaft revolution.

Formula section:

Application recurrence: once per crankshaft revolution.

- *Initialisation :*

At the transition to engine stopped: T_FCO = 0 and FCO_SUM_PREV = FCO_SUM

- *Active time duration T_FCO calculation :*

$$T_FCO = (FCO_SUM - FCO_SUM_PREV) * C_FCO_FAC$$

$$FCO_SUM_PREV = FCO_SUM$$

Calibration data:

Name	Dim	Hex. limits	Phys. limits	Resol.	Unit
C_FCO_FAC	1	0...FFH	0...1,922	7,509E-3	-
Scale factor depending on injector type for calculation of the active time duration T_FCO.					

Editor: Müller O.	17-Dec-97	Basic SW Inputs and Outputs	HMC_V6
Version: a 153589 from 18.12.97		657765.49.02	
File: CHAP_2.DOC	650H0000	Sourcefile:07201001.00A	Page 92 / 98

Proprietary data, company confidential. All rights reserved. Contient des informations confidentielles. Tous droits réservés. Comunicado como segredo empresarial. Reservados todos os direitos. Confidado como secreto industrial. Nos reservamos todos los derechos.

Weitergabe sowie Vervielfältigung dieser Unterlage, Wertung und Mitteilung ihres Inhalts nicht gestattet, soweit nicht ausdrücklich zugestanden. Zuwiderhandlungen verpflichten zu Schadenersatz. Alle Rechte vorbehalten, insbesondere für den Fall der Patenterteilung oder GM-Entragung.

2.2.4 Engine speed signal output ESS

2.2.4.1 Basic software

FUNCTION DESCRIPTION:

General information:

This specification is applicable for a 6 cylinders engine.

The ECU generates an engine speed signal (ESS) to be dispatched to other ECUs (Transmission Control Unit, Dashboard ...)

This output is only activated when the engine is running and the signal is representative of engine speed. It is performed with a fixed logic state ratio and a variable frequency proportional to the engine speed.

Initialisation :

The output signal is initialised with a low logic state (0).

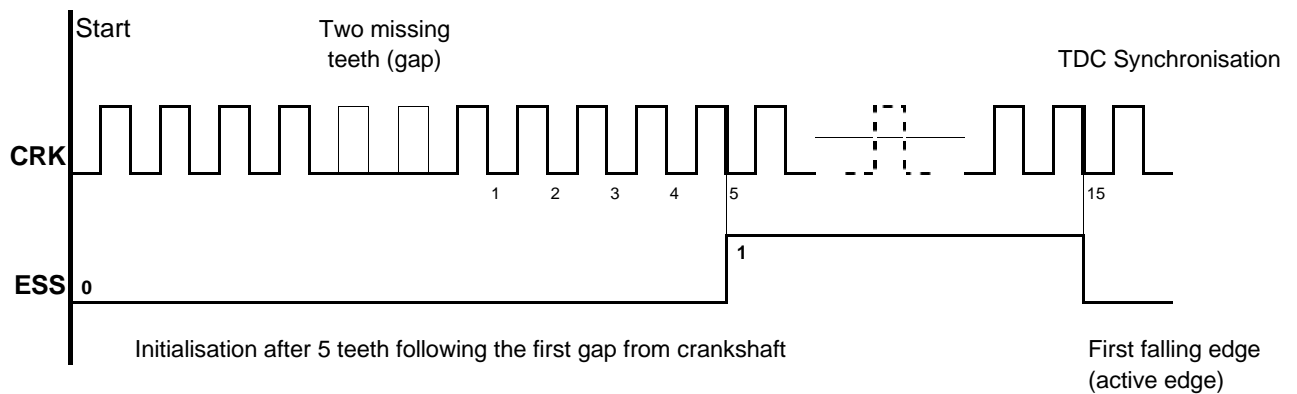

Formula section:

The active edge on the engine speed signal is the falling edge, corresponding to the TDC location.

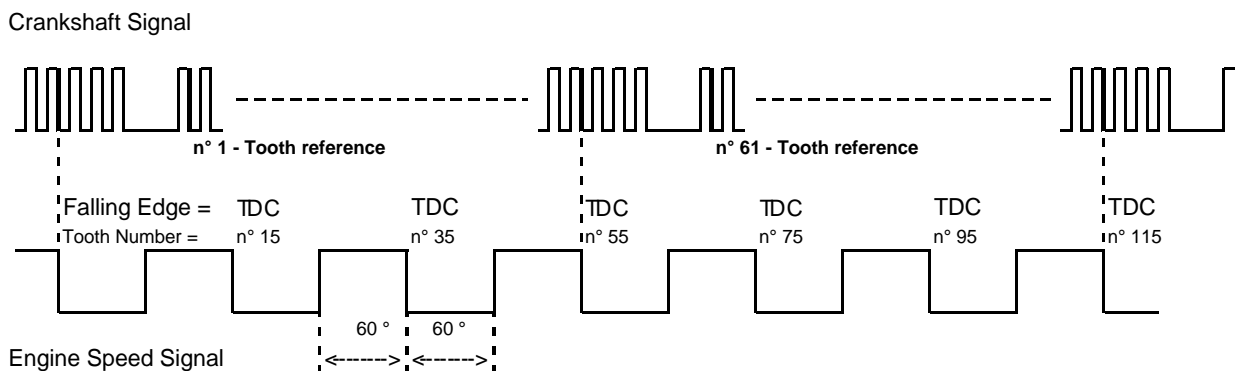

Editor: Müller O.	17-Dec-97	Basic SW Inputs and Outputs	HMC_V6
Version: a 153589 from 18.12.97		657765.49.02	
File: CHAP_2.DOC	650H0000	Sourcefile:07201201.00A	Page 93 / 98

Proprietary data, company confidential. All rights reserved. Contine a titre de secret d'entreprise. Tous droits réservés. Comunicado como segredo empresarial. Reservados todos os direitos. Confidado como secreto industrial. Nos reservamos todos los derechos.

Weitergabe sowie Vervielfältigung dieser Unterlage, Wertung und Mitteilung ihres Inhalts ist gestattet, soweit nicht ausdrücklich zugestanden. Zuwiderhandlungen verpflichten zu Schadensersatz. Alle Rechte vorbehalten, insbesondere für den Fall der Patenterteilung oder GM-Entragung.

2.2.5 Acquisition of primary over voltage duration V_DUR_IGC_[CYL]

Output data:

Name	Mode	Hex. limits	Phys. limits	Resol.	Unit
V_DUR_IGC_[CYL]	V/S	0...7FFFH	0...131000	4	µs
Ignition coil primary over voltage duration for the corresponding cylinder.					

Input data:

C_IGC_DUR_N_MAX_DIAG			
----------------------	--	--	--

FUNCTION DESCRIPTION:

General information:

This function is applicable with a 6 cylinders engine but the type of spark plugs and ignition coils (double or single output) must be taken into account.

The ignition coil primary over voltage duration **V_DUR_IGC_[CYL]** acquisition is provided for ignition diagnosis.

This duration is measured with a gated timer of the micro-processor, see also chapter „Diagnosis Management“. The gated timer is allowed to count after the turn-off of the ignition output until the turn-off of the following ignition output, to ensure in case of spark break-off a correct measurement.

The ignition coil primary over voltage of each ignition output of engines up to 6 cylinders are not overlapping in the normal operating mode at C_IGC_DUR_N_MAX_DIAG rpm engine speed. But the software strategy must detect overlapping. In this case the bit 15 of **V_DUR_IGC_[CYL]** is set to 1.

Failure on input gated timer : V_DUR_IGC_[CYL] = 0

Proprietary data, company confidential. All rights reserved. Contine a titre de secret d'entreprise. Tous droits réservés. Comunicado como segredo empresarial. Reservados todos os direitos. Confidado como secreto industrial. Nos reservamos todos los derechos.

Weitergabe sowie Vervielfältigung dieser Unterlage, Verwertung und Mitteilung ihres Inhalts nicht gestattet, soweit nicht ausdrücklich zugestanden. Zuwiderhandlungen verpflichten zu Schadensersatz. Alle Rechte vorbehalten, insbesondere für den Fall der Patenterteilung oder GM-Eintragung.

Editor: Müller O.	17-Dec-97	Basic SW Inputs and Outputs	HMC_V6
Version: a 153589 from 18.12.97		657765.49.02	
File: CHAP_2.DOC	650H0000	Sourcefile:07201D01.00A	Page 94 / 98

Description:

V_DUR_IGC_[CYL] is calculated with a gated timer and respects spark break-off as well as overlapping.

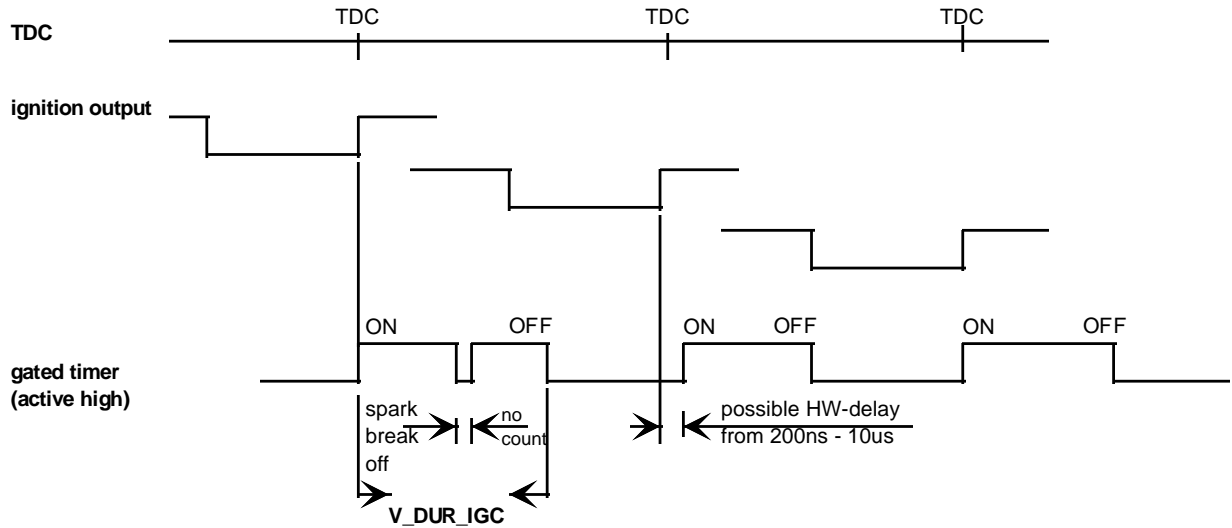

Proprietary data, company confidential. All rights reserved.
 Contient a titre de secret d'entreprise. Tous droits réservés.
 Comunicado como secreto empresarial. Reservados todos os direitos.
 Confidado como secreto industrial. Nos reservamos todos los derechos.

Weitergabe sowie Vervielfältigung dieser Unterlage, Verwertung und Mitteilung ihres Inhalts nicht gestattet, soweit nicht ausdrücklich zugestanden. Zuwiderhandlungen verpflichten zu Schadensersatz. Alle Rechte vorbehalten, insbesondere für den Fall der Patenterteilung oder GM-Eintragung.

Editor: Müller O.	17-Dec-97	Basic SW Inputs and Outputs	HMC_V6
Version: a 153589 from 18.12.97		657765.49.02	
File: CHAP_2.DOC	650H0000	Sourcefile:07201D01.00A	Page 95 / 98

2.2.6 Acquisition of throttle position

2.2.6.1 Basic software

Output data:

Name	Mode	Hex. limits	Phys. limits	Resol.	Unit
TPS_MES	V	0...FFH	0...4,9805	5 / 256	V.
Throttle position sensor voltage measured (8 bits).					
TPS_MES_10	-	0...03FFH	0...4,9951	5 / 1024	V.
Throttle position sensor voltage measured (10 bits).					

Input data:

TPS_BAS			
---------	--	--	--

FUNCTION DESCRIPTION:

General information:

The raw value for throttle position (TPS_BAS) is measured by continuous conversion (10 bits) every 1 msec.

The corresponding value of the first measurement after hardware reset is used for initialisation.

Formula section:

TPS_MES_10 ← TPS_BAS (10 bits)

TPS_MES ← TPS_BAS / 4 (8 bits)

Proprietary data, company confidential. All rights reserved. Contient a titre de secret d'entreprise. Tous droits réservés. Comunicado como segredo empresarial. Reservados todos os direitos. Comunicado como secreto industrial. Nos reservamos todos los derechos.

Weitergabe sowie Vervielfältigung dieser Unterlage, Wertung und Mitteilung ihres Inhalts nicht gestattet, soweit nicht ausdrücklich zugestanden. Zuwiderhandlungen verpflichten zu Schadensersatz. Alle Rechte vorbehalten, insbesondere für den Fall der Patenterteilung oder GM-Enttragung

Editor: Müller O.	17-Dec-97	Basic SW Inputs and Outputs	HMC_V6
Version: a 153589 from 18.12.97		657765.49.02	
File: CHAP_2.DOC	650H0000	Sourcefile:07201Q01.00B	Page 96 / 98

2.2.6.2 Applicative software

Output data:

Name	Mode	Hex. limits	Phys. limits	Resol.	Unit
TPS	V	0...FFH	0...119,5	0,47	°TPS
Relative throttle angle.					
TPS_CAN	V	20...F5H	0...100	0,444	%
Relative throttle angle distributed via CAN.					

Input data:

TPS_MES_DIAG	TPS_MES_10_DIAG	LV_TPS_ERR	TPS_AD_MMV_IS
--------------	-----------------	------------	---------------

FUNCTION DESCRIPTION:

General information:

The application recurrence is **10 msec**.

Formula section:

** Hysteresis :*

To filter out signal noise, the signal is filtered using the adjustable value C_TPS_HYS. The throttle angle is accepted only if TPS_MES_10_DIAG differs from the value last measured by more than C_TPS_HYS and if the conditions for a plausibility diagnosis error are not fulfilled (LV_TPS_ERR = 0).

** Gradient :*

In order for possible malfunctions not to become effective, a permissible throttle gradient is checked for exceeding. The old measured value TPS_MES_DIAG remains the same if the difference between the old and the new value is greater than C_TPS_GRD_MAX.

If $| \text{TPS_MES_10_DIAG}_n - \text{TPS_MES_10_DIAG}_{n-1} | > \text{C_TPS_HYS}$

then

if $| \text{TPS_MES_DIAG}_n - \text{TPS_MES_DIAG}_{n-1} | < \text{C_TPS_GRD_MAX}$

then $\text{TPS} = \text{TPS_MES_DIAG}_n - \text{TPS_AD_MMV_IS}$ with $\text{TPS} \geq 0$

else $\text{TPS} = \text{TPS_MES_DIAG}_{n-1} - \text{TPS_AD_MMV_IS}$ with $\text{TPS} \geq 0$

Remark : If during the subsequent measurement period (10 msec) it is determined again that C_TPS_GRD_MAX was exceeded, the new measured value is taken as valid.

Editor: Müller O.	17-Dec-97	Basic SW Inputs and Outputs	HMC_V6
Version: a 153589 from 18.12.97		657765.49.02	
File: CHAP_2.DOC	650H0000	Sourcefile:07201Q01.00B	Page 97 / 98

Calibration data:

Name	Dim	Hex. limits	Phys. limits	Resol.	Unit
C_TPS_HYS	1	0...03FFH	0...119,88	120/1024	°TPS
Noise filtering factor for TPS.					
C_TPS_GRD_MAX	1	0...FFH	0...119,5	0,47	°TPS
Maximum TPS gradient.					

Proprietary data, company confidential. All rights reserved.
 Contine a titre de secret d'entreprise. Tous droits réservés.
 Comunicado como segredo empresarial. Reservados todos os direitos.
 Confidado como secreto industrial. Nos reservamos todos los derechos.

Weitergabe sowie Vervielfältigung dieser Unterlage, Verwertung und Mitteilung ihres Inhalts nicht gestattet, soweit nicht ausdrücklich zugestanden. Zuwiderhandlungen verpflichten zu Schadensersatz. Alle Rechte vorbehalten, insbesondere für den Fall der Patenterteilung oder GM-Eintragung

Editor: Müller O.	17-Dec-97	Basic SW Inputs and Outputs	HMC_V6
Version: a 153589 from 18.12.97		657765.49.02	
File: CHAP_2.DOC	650H0000	Sourcefile:07201Q01.00B	Page 98 / 98

Document: **System variables**

Project: **Engine Management System**
HMC_V6

Version: a

Date: 17-Dec-97

Number of pages: 47

Revision Code-No.: 153589 from 18.12.97

Construction protocol-No.:

Software version: 650H0000

	Name	Department	Phone	Date	Sign
Author	Müller O.	AT PT SI TSA 11	3211	09.12.97	
1. Check	Pioch O.	AT PT SI TSA 11	3212	09.12.97	
2. Check	Gessner S.	AT PT SI TSA 11	5398	09.12.97	
Responsible	Brückner D.	AT PT SI TSA 16	4279	09.12.97	

Version list

Proprietary data, company confidential. All rights reserved. Contine a titre de secret d'entreprise. Tous droits réservés. Comunicado como secreto empresarial. Reservados todos os direitos. Confidado como secreto industrial. Nos reservamos todos los derechos.

Weitergabe sowie Vervielfältigung dieser Unterlage, Wertung und Mitteilung ihres Inhalts nicht gestattet, soweit nicht ausdrücklich zugestanden. Zuwiderhandlungen verpflichten zu Schadensersatz. Alle Rechte vorbehalten, insbesondere für den Fall der Patenterteilung oder GM-Eintragung

Version	Date	Author	Comment, Description

Editor:	Müller O.	17-Dec-97	System variables	HMC_V6
Version:	a 153589 from 18.12.97		657765.49.03	
File:	CHAP_4.DOC	650H0000		Page 2 / 47

Table of contents

Page

1	System variables	10
1.1	Engine speed variables	10
1.1.1	Engine speed N and N_32	10
1.1.2	Nominal idle speed N_SP_IS	11
1.1.3	Nominal idle speed threshold N_SP_IS_MAX	14
1.1.4	Engine speed gradient N_GRD	15
1.1.5	Engine speed deviations N_DIF, N_DIF_MMV, N_DIF_COR	16
1.1.6	Engine running detected during last system run	19
1.2	Mass air flow variables	20
1.2.1	Calculation of mass air flow correction MAF	20
1.2.2	Air mass difference for rapidly falling load MAF_MMV, MAF_MMV_DIF	23
1.2.3	Mass air flow ratio calculation MAF_RATIO_PUR, MAF_RATIO_AE	24
1.2.4	Altitude correction MAF_FAC_ALTI, MAF_ALTI_COR	25
1.3	Throttle angle variables	29
1.3.1	Throttle potentiometer adaptation TPS_AD_MMV_IS	29
1.3.1.1	Initialization of throttle potentiometer adaptation	29
1.3.1.2	Calculation of the throttle potentiometer adaptation TPS_AD_MMV_IS	30
1.3.2	Closed throttle definition LV_CT	32
1.3.3	Throttle gradient TPS_GRD	33
1.3.4	Full load throttle threshold LV_TPS_FL	34
1.4	Vehicle speed variables	35
1.4.1	Vehicle speed VS	35
1.4.2	Vehicle speed for rough road detection VS_RR	37
1.4.3	Vehicle speed state VS_STATE_CFA	38
1.5	Coolant temperature variables	40
1.5.1	Coolant temperature TCO	40
1.5.2	Coolant temperature at start TCO_ST	41
1.5.3	Coolant temperature at re-start TCO_REST	42
1.6	Intake Air Temperature Variable TIA	43
1.6.1	Intake Air Temperature at Start TIA_ST	44
1.7	Gear ratio	45
1.8	Idle speed actuator variables	46
1.8.1	Time delay to apply drive correction	46

Proprietary data, company confidential. All rights reserved.
 Contine a titre de secret d'entreprise. Tous droits réservés.
 Comunicado como secreto empresarial. Reservados todos os direitos.
 Confidado como secreto industrial. Nos reservamos todos los derechos.

Weitergabe sowie Vervielfältigung dieser Unterlage, Verwertung und Mitteilung ihres Inhalts nicht gestattet, soweit nicht ausdrücklich zugestanden. Zuwiderhandlungen verpflichten zu Schadenersatz. Alle Rechte vorbehalten, insbesondere für den Fall der Patenterteilung oder GM-Entragung.

Editor:	Müller O.	17-Dec-97	System variables	HMC_V6
Version:	a 153589 from 18.12.97		657765.49.03	
File:	CHAP_4.DOC	650H0000		Page 3 / 47

Index

Page

C

C_MAF_ALTI_MIN	
def.....	28
C_MAF_CRLC_INF	
def.....	22
C_MAF_CRLC_IS	
def.....	22
C_MAF_FAC_ALT_DIF_MAX_PUC	
def.....	28
C_MAF_FAC_ALT_DIF_MIN_PUC	
def.....	28
C_MAF_FAC_ALTI_CRLC	
def.....	28
C_MAF_FAC_ALTI_MMV_MAX	
def.....	28
C_MAF_FAC_ALTI_MMV_MIN	
def.....	28
C_MAF_MMV_DIF_CRLC	
def.....	23
C_N_DIF_CRLC	
def.....	18
C_N_DIF_FAC	
def.....	14, 18
C_N_DIF_MAX_IS	
def.....	14
C_N_DIF_MIN_MMV	
def.....	18
C_N_SP_LGRD_IS	
def.....	13
C_T_DLY_ISAPWM_RVS_DEC	
def.....	47
C_T_DLY_ISAPWM_RVS_INC	
def.....	47
C_T_MAF_ALTI_MIN_PUC	
def.....	28
C_TCO_GRD_MAX_DIAG	
def.....	40
C_TCO_MAF_ALTI_MIN	
def.....	28
C_TIA_GRD_MAX_DIAG	
def.....	43
C_TPS_AD_CRLC	
def.....	31
C_TPS_ADD	
def.....	31
C_TPS_HYS_FL	
def.....	34
C_TPS_IS	
def.....	31
C_TPS_MAF_ALTI_MIN	
def.....	28
C_TPS_MAX_IS	

Proprietary data, company confidential. All rights reserved.
 Contit a titre de secret d'entreprise. Tous droits réservés.
 Comunicado como segredo empresarial. Reservados todos os direitos.
 Confidado como secreto industrial. Nos reservamos todos los derechos.

Weitergabe sowie Vervielfältigung dieser Unterlage, Verwertung und Mitteilung ihres Inhalts nicht gestattet, soweit nicht ausdrücklich zugestanden. Zuwiderhandlungen verpflichten zu Schadensersatz. Alle Rechte vorbehalten, insbesondere für den Fall der Patenterteilung oder GM-Entragung.

Editor: Müller O.	17-Dec-97	System variables	HMC_V6
Version: a 153589 from 18.12.97		657765.49.03	
File: CHAP_4.DOC	650H0000		Page 4 / 47

def.....	31
C_TPS_MIN_MAF_KGH_DIAG	
def.....	31
C_VS_1_CFA	
def.....	39
C_VS_2_CFA	
def.....	39
C_VS_3_CFA	
def.....	39
C_VS_FAC_0	
def.....	36
C_VS_FAC_1_2	
def.....	36
C_VS_HYS_1_CFA	
def.....	39
C_VS_HYS_2_CFA	
def.....	39
C_VS_MAX_0	
def.....	36
C_VS_MAX_1_2	
def.....	36
C_VS_MIN_0	
def.....	36
C_VS_MIN_1_2	
def.....	36
CONF_MIS	
use.....	37
CONF_TCU	
use.....	45
CONF_VS	
use.....	35
CRK_VS_RR_N_RATIO_OSC	
use.....	45
D	
DRI_N_SP_ADD_CH	
def.....	11
G	
GR_MT	
def.....	45
I	
ID_GR_MT	
def.....	45
ID_TPS_FL__N_32	
def.....	34
IP_ACIN_N_SP_IS__TCO	
def.....	13
IP_DRI_ACIN_N_SP_IS__TCO	
def.....	13
IP_DRI_N_SP_ADD_CH__TCO	
def.....	13
IP_DRI_N_SP_IS__TCO	
def.....	13
IP_FAC_N_SP_IS__TCO	
def.....	13
IP_MAF_CRLC_PL__N_32__MAF_MES	

Editor: Müller O.	17-Dec-97	System variables	HMC_V6
Version: a 153589 from 18.12.97		657765.49.03	
File: CHAP_4.DOC	650H0000		Page 5 / 47

def.....	22
IP_MAF_CRLC_PU__N_32	
def.....	22
IP_MAF_CRLC_PUR__N_32__MAF_MES	
def.....	22
IP_N_MAX_TOL_ST__TCO	
use.....	42
IP_N_SP_ADD_CH__TCO	
def.....	13
IP_N_SP_IS__TCO	
def.....	13
IP_T_DLY_ISAPWM_DRI_DEC__TCO	
def.....	47
IP_T_DLY_ISAPWM_DRI_INC__TCO	
def.....	47
L	
LV_ACCIN	
use.....	38
LV_ACIN	
use.....	11
LV_AE	
use.....	20, 24, 25
LV_CRK_ERR	
use.....	45
LV_CT	
def.....	32
LV_DRI	
use.....	11, 46
LV_DRI_ISAPWM	
def.....	46
LV_ENG_RUN_IS_PL	
def.....	19
LV_ES	
use.....	42
LV_INF	
use.....	20
LV_IS	
use.....	19, 20
LV_ISA_i_ERR	
use.....	25
LV_IV_[CYL]_ERR	
use.....	25
LV_MAF_ERR	
use.....	25
LV_MAF_PLAUS_ERR	
use.....	25
LV_N_SP_ADD_CH	
use.....	11
LV_PL	
use.....	19, 23, 25
LV_PU	
use.....	23
LV_PUC	
use.....	23, 25
LV_PUR	
use.....	20, 24, 25

Editor: Müller O.	17-Dec-97	System variables	HMC_V6
Version: a 153589 from 18.12.97		657765.49.03	
File: CHAP_4.DOC	650H0000		Page 6 / 47

Proprietary data, company confidential. All rights reserved.
 Contine a titre de secret d'entreprise. Tous droits réservés.
 Comunicado como segredo empresarial. Reservados todos os direitos.
 Confidado como secreto industrial. Nos reservamos todos los derechos.

Weitergabe sowie Vervielfältigung dieser Unterlage, Verwertung und Mitteilung ihres Inhalts nicht gestattet, soweit nicht ausdrücklich zugestanden. Zuwiderhandlungen verpflichten zu Schadenersatz. Alle Rechte vorbehalten, insbesondere für den Fall der Patenterteilung oder GM-Entragung.

LV_ST	
use.....	19, 20, 41, 44
LV_TIA_ERR	
use.....	25
LV_TPS_ERR	
use.....	25, 29
LV_TPS_FL	
def.....	34
LV_TPS_PLAUS_ERR	
use.....	25
LV_VS_ERR	
use.....	29, 38, 45
LV_WUP	
use.....	25
M	
MAF	
def.....	20
use.....	23, 24, 25
MAF_ALTI_COR	
def.....	25
MAF_FAC_ALTI	
def.....	25
MAF_FAC_ALTI_MAX_PUC	
def.....	25
MAF_FAC_ALTI_MMV	
def.....	25
MAF_FAC_ALTI_MMV_CAN	
def.....	25
MAF_KGH	
use.....	25
MAF_KGH_SUB_DIAG	
use.....	25
MAF_MES	
use.....	20, 24
MAF_MMV	
def.....	23
MAF_MMV_DIF	
def.....	23
MAF_RATIO_AE	
def.....	24
MAF_RATIO_PUR	
def.....	24
N	
N	
def.....	10
use.....	15, 16, 42
N_32	
def.....	10
use.....	20
N_DIF	
def.....	16
N_DIF_COR	
def.....	16
N_DIF_MMV	
def.....	16

Editor: Müller O.	17-Dec-97	System variables	HMC_V6
Version: a 153589 from 18.12.97		657765.49.03	
File: CHAP_4.DOC	650H0000		Page 7 / 47

use.....	14
N_GRD	
def.....	15
N_SP_ADD_CH	
def.....	11
N_SP_IS	
def.....	11
use.....	14, 16
N_SP_IS_ADJ_ASA	
use.....	11
N_SP_IS_MAX	
def.....	14
NC_CYL_NO	
def.....	10
NC_ISAPWM_N_MAX	
def.....	13, 18
NC_N_DIF_MIN_CRLC	
def.....	18
NC_N_SP_IS_MAX	
def.....	13
NC_T1_FREQ	
def.....	10, 15
S	
SEG_T_MES_0_RR	
use.....	35
T	
T_SEG	
use.....	10, 15
TCO	
def.....	40
use.....	11, 25, 41, 42
TCO_MES	
use.....	40
TCO_REST	
def.....	42
TCO_ST	
def.....	41
TIA	
def.....	43
use.....	44
TIA_MES	
use.....	43
TIA_ST	
def.....	44
TPS	
use.....	29, 32, 33, 34
TPS_AD_MMV_IS	
def.....	29
TPS_GRD	
def.....	33
TPS_MES	
use.....	29
V	
VS	
def.....	35

Editor: Müller O.	17-Dec-97	System variables	HMC_V6
Version: a 153589 from 18.12.97		657765.49.03	
File: CHAP_4.DOC	650H0000		Page 8 / 47

Proprietary data, company confidential. All rights reserved.
 Contitue a titre de secret d'entreprise. Tous droits réservés.
 Comunicado como secreto empresarial. Reservados todos os direitos.
 Confidado como secreto industrial. Nos reservamos todos los derechos.

Weitergabe sowie Vervielfältigung dieser Unterlage, Verwertung und Mitteilung ihres Inhalts nicht gestattet, soweit nicht ausdrücklich zugestanden. Zuwiderhandlungen verpflichten zu Schadensersatz. Alle Rechte vorbehalten, insbesondere für den Fall der Patenterteilung oder GM-Entragung

use.....	20, 29, 37, 38, 45
VS_FAC	
def.....	35
VS_MAX	
def.....	35
VS_MIN	
def.....	35
VS_RR	
def.....	37
VS_SEG_T_MES	
use.....	35
VS_STATE_CFA	
def.....	38

Editor: Müller O.	17-Dec-97	System variables	HMC_V6
Version: a 153589 from 18.12.97		657765.49.03	
File: CHAP_4.DOC	650H0000		Page 9 / 47

Proprietary data, company confidential. All rights reserved.
 Contit a titre de secret d'entreprise. Tous droits réservés.
 Comunicado como segredo empresarial. Reservados todos os direitos.
 Confidado como secreto industrial. Nos reservamos todos los derechos.

Weitergabe sowie Vervielfältigung dieser Unterlage, Verwertung und Mitteilung ihres Inhalts nicht gestattet, soweit nicht ausdrücklich zugestanden. Zuwiderhandlungen verpflichten zu Schadensersatz. Alle Rechte vorbehalten, insbesondere für den Fall der Patenterteilung oder GM-Entragung.

1 System variables

1.1 Engine speed variables

1.1.1 Engine speed N and N_32

Output data:

Name	Mode	Hex. limits	Phys. limits	Resol.	Unit
N_32	V	0...FFH	0...8160	32	rpm
Engine speed - Resolution 32 rpm.					
N	V	0...1FE0H	0...8160	1	rpm
Engine speed - Resolution 1 rpm					

Input data:

T_SEG			
-------	--	--	--

FUNCTION DESCRIPTION:

General information:

The engine speed is determined in each segment from the segment period. The time for the passage of this segment T_SEG is measured with a resolution of 1 / NC_T1_FREQ microseconds. This method is used to determine engine speed in the entire engine speed range.

Formula section:

- $N = NC_T_SEG_ES_CLC / T_SEG$

with $NC_T_SEG_ES_CLC = NC_T1_FREQ \times 60 \times 2 / NC_CYL_NO$

- $N_32 = N / 32$

Calibration data:

Name	Dim	Hex. limits	Phys. limits	Resol.	Unit
NC_T1_FREQ	1			1	Hz
Timer frequency - Non adjustable calibration.					
NC_CYL_NO	1	0...FFH	0...255	1	-
Number of cylinders - Non adjustable calibration.					

Applicative Values :

NC_T1_FREQ = 250 kHz

NC_CYL_NO = 06H = 6 cylinders

Editor: Müller O.	17-Dec-97	System variables	HMC_V6
Version: a 153589 from 18.12.97		657765.49.03	
File: CHAP_4.DOC	650H0000	Sourcefile:07400102.00J	Page 10 / 47

1.1.2 Nominal idle speed N_SP_IS

Output data:

Name	Mode	Hex. limits	Phys. limits	Resol.	Unit
N_SP_IS	V	0...1FE0H	0...8160	1	rpm
Nominal idle speed.					
N_SP_ADD_CH	V	0...1FE0H	0...8160	1	rpm
Nominal idle speed offset with catalyst heating function and LV_DRI = 0					
DRI_N_SP_ADD_CH	V	0...1FE0H	0...8160	1	rpm
Nominal idle speed offset with catalyst heating function and LV_DRI = 1					

Input data:

TCO	LV_ACIN	LV_DRI	LV_N_SP_ADD_CH
N_SP_IS_ADJ_ASA			

FUNCTION DESCRIPTION:

General information:

The nominal idle speed in the engine operating state Idle (LV_IS) depends on:

- Coolant temperature TCO
- Catalyst heating function LV_N_SP_ADD_CH
- the additional loads: Drive with A/T gearbox, air conditioning.
- Adjustment by service tester/keyword

The offset N_SP_ADD_CH is applied on N_SP_IS if catalyst heating function is active.

The transition from a nominal idle speed to another is performed with an adjustable change limitation C_N_SP_LGRD_IS

Formula section:

- N_SP_ADD_CH calculation :

If LV_N_SP_ADD_CH = 1

then N_SP_ADD_CH = IP_N_SP_ADD_CH_TCO

else N_SP_ADD_CH = 0

Proprietary data, company confidential. All rights reserved. Contient des informations confidentielles. Tous droits réservés. Comunicado como secreto empresarial. Reservados todos los derechos. Confidado como secreto industrial. Nos reservamos todos los derechos.

Weitergabe sowie Vervielfältigung dieser Unterlage, Wertung und Mitteilung ihres Inhalts nicht gestattet, soweit nicht ausdrücklich zugestanden. Zuwiderhandlungen verpflichten zu Schadensersatz. Alle Rechte vorbehalten, insbesondere für den Fall der Patenterteilung oder GM-Entragung.

Editor: Müller O.	17-Dec-97	System variables	HMC_V6
Version: a 153589 from 18.12.97		657765.49.03	
File: CHAP_4.DOC	650H0000	Sourcefile:07400102.00J	Page 11 / 47

Proprietary data, company confidential. All rights reserved.
 Contient des informations confidentielles. Tous droits réservés.
 Contiene datos de la compañía confidencial. Reservados todos los derechos.
 Comunicado como segredo empresarial. Reservados todos os direitos.
 Confidado como secreto industrial. Nos reservamos todos los derechos.

Weitergabe sowie Vervielfältigung dieser Unterlage, Verwertung und Mitteilung ihres Inhalts ist gestattet, soweit nicht ausdrücklich zugestanden. Zuwiderhandlungen verpflichten zu Schadensersatz. Alle Rechte vorbehalten, insbesondere für den Fall der Patenterteilung oder GM-Entragung.

- DRI_N_SP_ADD_CH calculation :

If LV_N_SP_ADD_CH = 1

then DRI_N_SP_ADD_CH = IP_DRI_N_SP_ADD_CH_TCO

else DRI_N_SP_ADD_CH = 0

- N_SP_IS calculation :

Nominal idle speed without additional load (LV_DRI = 0 and LV_ACIN = 0) :

**N_SP_IS = IP_N_SP_IS_TCO
 + N_SP_ADD_CH
 + N_SP_IS_ADJ_ASA * IP_FAC_N_SP_IS_TCO**

Nominal idle speed with DRIVE (A/T) position engaged (LV_DRI = 1 and LV_ACIN = 0) :

**N_SP_IS = IP_DRI_N_SP_IS_TCO
 + DRI_N_SP_ADD_CH
 + N_SP_IS_ADJ_ASA * IP_FAC_N_SP_IS_TCO**

Nominal idle speed with air conditioner switched on (LV_DRI = 0 and LV_ACIN = 1) :

**N_SP_IS = IP_ACIN_N_SP_IS_TCO
 + N_SP_IS_ADJ_ASA * IP_FAC_N_SP_IS_TCO**

Nominal idle speed with DRIVE (A/T) position engaged and air conditioner switched on (LV_DRI = 1 and LV_ACIN = 1) :

**N_SP_IS = IP_DRI_ACIN_N_SP_IS_TCO
 + N_SP_IS_ADJ_ASA * IP_FAC_N_SP_IS_TCO**

N_SP_IS is computed below the engine speed NC_ISAPWM_N_MAX.

N_SP_IS is limited to NC_N_SP_IS_MAX.

Editor: Müller O.	17-Dec-97	System variables	HMC_V6
Version: a 153589 from 18.12.97		657765.49.03	
File: CHAP_4.DOC	650H0000	Sourcefile:07400102.00J	Page 12 / 47

Calibration data:

Name	Dim	Hex. limits	Phys. limits	Resol.	Unit
IP_N_SP_IS_TCO	6	0...1FE0H	0...8160	1	rpm
Nominal idle speed without additional load on the engine.					
IP_DRI_N_SP_IS_TCO	6	0...1FE0H	0...8160	1	rpm
Nominal idle speed with DRIVE (A/T) engaged.					
IP_ACIN_N_SP_IS_TCO	6	0...1FE0H	0...8160	1	rpm
Nominal idle speed with air conditioner switched on.					
IP_DRI_ACIN_N_SP_IS_TCO	6	0...1FE0H	0...8160	1	rpm
Nominal idle speed with DRIVE (A/T) engaged and air conditioner switched on.					
IP_FAC_N_SP_IS_TCO	9	0...FFH	0...0,9961	1/256	-
Correction factor for nominal idle speed adjustment.					
C_N_SP_LGRD_IS	1	01...FFH	0,25...63,75	0,25	rpm
Nominal idle speed change limitation.					
IP_N_SP_ADD_CH_TCO	6	0...1FE0H	0...8160	1	rpm
Nominal idle speed offset with catalyst heating function active and LV_DRI = 0					
IP_DRI_N_SP_ADD_CH_TCO	6	0...1FE0H	0...8160	1	rpm
Nominal idle speed offset with catalyst heating function active and LV_DRI = 1					
NC_ISAPWM_N_MAX	1	0...FFH	0...8160	32	rpm
Maximum engine speed threshold for calculation of N_SP_IS - Non adjustable calibration.					
NC_N_SP_IS_MAX	1	0...FFH	0...8160	32	rpm
Maximum engine speed value for N_SP_IS - Non adjustable calibration.					

Applicative Values :

NC_ISAPWM_N_MAX = 4EH = 2496 rpm.

NC_N_SP_IS_MAX = FFH = 8160 rpm

Proprietary data, company confidential. All rights reserved.
 Contit a titre de secret d'entreprise. Tous droits réservés.
 Comunicado como segredo empresarial. Reservados todos os direitos.
 Confidado como secreto industrial. Nos reservamos todos los derechos.

Weitergabe sowie Vervielfältigung dieser Unterlage, Verwertung und Mitteilung ihres Inhalts nicht gestattet, soweit nicht ausdrücklich zugestanden. Zuwiderhandlungen verpflichten zu Schadensersatz. Alle Rechte vorbehalten, insbesondere für den Fall der Patenterteilung oder GM-Entragung.

Editor: Müller O.	17-Dec-97	System variables	HMC_V6
Version: a 153589 from 18.12.97		657765.49.03	
File: CHAP_4.DOC	650H0000	Sourcefile:07400102.00J	Page 13 / 47

1.1.3 Nominal idle speed threshold N_SP_IS_MAX

Output data:

Name	Mode	Hex. limits	Phys. limits	Resol.	Unit
N_SP_IS_MAX	V	0...1FE0H	0...8160	1	rpm
Nominal idle speed threshold.					

Input data:

N_SP_IS	N_DIF_MMV		
---------	-----------	--	--

FUNCTION DESCRIPTION:

General information:

In order to define the basic engine operating states, the nominal engine speed threshold is available.

Formula section:

In idle (LV_IS) :

$$N_SP_IS_MAX = N_SP_IS + C_N_DIF_MAX_IS - N_DIF_MMV * C_N_DIF_FAC$$

Out of idle :

$$N_SP_IS_MAX = N_SP_IS + C_N_DIF_MAX_IS$$

Calibration data:

Name	Dim	Hex. limits	Phys. limits	Resol.	Unit
C_N_DIF_FAC	1	00...FFH	0...0,997	3,895E-3	-
Weighting factor for the idle speed variable controller.					
C_N_DIF_MAX_IS	1	0...1FE0H	0...8160	1	rpm
Engine speed hysteresis before engine operating state idle (LV_IS).					

Proprietary data, company confidential. All rights reserved. Contient a titre de secret d'entreprise. Tous droits réservés. Comunicado como segredo empresarial. Reservados todos os direitos. Confidado como secreto industrial. Nos reservamos todos los derechos.

Weitergabe sowie Vervielfältigung dieser Unterlage, Verwertung und Mitteilung ihres Inhalts nicht gestattet, soweit nicht ausdrücklich zugestanden. Zuwiderhandlungen verpflichten zu Schadensersatz. Alle Rechte vorbehalten, insbesondere für den Fall der Patenterteilung oder GM-Eintragung.

Editor: Müller O.	17-Dec-97	System variables	HMC_V6
Version: a 153589 from 18.12.97		657765.49.03	
File: CHAP_4.DOC	650H0000	Sourcefile:07400102.00J	Page 14 / 47

1.1.4 Engine speed gradient N_GRD

Output data:

Name	Mode	Hex. limits	Phys. limits	Resol.	Unit
N_GRD	V	80...7FH	-4096 : 4064	32	rpm/s
Engine speed gradient					

Input data:

T_SEG	N	
-------	---	--

FUNCTION DESCRIPTION:

General information:

The engine speed gradient calculation is triggered every segment.

Formula section:

The engine-speed gradients are calculated from the corresponding segment periods :

$$T_REV_ACT = (T_SEG_n + T_SEG_{n-1} + T_SEG_{n-2})$$

$$T_REV_LAST = (T_SEG_{n-3} + T_SEG_{n-4} + T_SEG_{n-5})$$

$N_GRD = 60 * NC_T1_FREQ^2 * Fehler!$

The timer resolution is 1 / NC_T1_FREQ and the formula above produce the engine-speed dependent resolutions of the engine-speed gradient without taking into account errors introduced by rounding or evaluation. The following deviation is caused by the timer resolution :

$\Delta N_GRD = Fehler!$

Calibration data:

Name	Dim	Hex. limits	Phys. limits	Resol.	Unit
NC_T1_FREQ	1				
Timer frequency - Non adjustable calibration.					

Applicative Values :

NC_T1_FREQ = 250 kHz

Editor: Müller O.	17-Dec-97	System variables	HMC_V6
Version: a 153589 from 18.12.97		657765.49.03	
File: CHAP_4.DOC	650H0000	Sourcefile:07400102.00J	Page 15 / 47

Proprietary data, company confidential. All rights reserved. Contine a titre de secret d'entreprise. Tous droits réservés. Comunicado como segredo empresarial. Reservados todos os direitos. Confidado como secreto industrial. Nos reservamos todos los derechos.

Weitergabe sowie Vervielfältigung dieser Unterlage, Verwertung und Mitteilung ihres Inhalts nicht gestattet, soweit nicht ausdrücklich zugestanden. Zuwiderhandlungen verpflichten zu Schadensersatz. Alle Rechte vorbehalten, insbesondere für den Fall der Patenterteilung oder GM-Enttragung.

1.1.5 Engine speed deviations N_DIF, N_DIF_MMV, N_DIF_COR

Output data:

Name	Mode	Hex. limits	Phys. limits	Resol.	Unit
N_DIF	V	8000H... 7FFFH	-32768 : 32767	1	rpm
Engine speed deviation.					
N_DIF_MMV	V	8000H... 7FFFH	-32768 : 32767	1	rpm
N_DIF moving mean value.					
N_DIF_COR	V	8000H... 7FFFH	-32768 : 32767	1	rpm
Idle speed control variable.					

Input data:

N	N_SP_IS		
---	---------	--	--

FUNCTION DESCRIPTION:

Formula section:

* *N_DIF calculation :*

The application recurrence is the **segment**. The deviation N_DIF from the nominal idle speed is defined as :

$$N_DIF = N_SP_IS - N$$

Remark : N_DIF is computed if $N \leq NC_ISAPWM_N_MAX$.

* *N_DIF_MMV calculation :*

As soon as the engine operating state idle (LV_IS) is set, N_DIF_MMV is set to N_DIF taking into account the limits defined below. Then the moving mean value is determined :

$$N_DIF_MMV(n) = N_DIF_MMV(n-1) * (1 - C_N_DIF_CRLC) + N_DIF * C_N_DIF_CRLC$$

The correlation constant C_N_DIF_CRLC may assume 3 discrete values :

- a1) Decreasing engine speed above nominal idle speed as soon as idle is set (LV_IS) **and** conditions b) & c) not previously met (**or** $N_DIF < NC_N_DIF_MIN_CRLC$) :
 $(N_DIF(n-3) < N_DIF(n) \quad \text{and} \quad N_DIF(n) < 0)$

$$C_N_DIF_CRLC = C_N_DIF_CRLC \quad (\text{per adjustment})$$

- a2) Decreasing engine speed above nominal idle speed **and** $N_DIF > NC_N_DIF_MIN_CRLC$ **and** condition b) previously fulfilled :

$$C_N_DIF_CRLC = 1$$

Proprietary data, company confidential. All rights reserved. Contient des informations confidentielles. Tous droits réservés. Comunicado como segredo empresarial. Reservados todos os direitos. Confidado como secreto industrial. Nos reservamos todos los derechos.

Weitergabe sowie Vervielfältigung dieser Unterlage, Verwertung und Mitteilung ihres Inhalts ist nicht gestattet, soweit nicht ausdrücklich zugestanden. Zuwiderhandlungen verpflichten zu Schadensersatz. Alle Rechte vorbehalten, insbesondere für den Fall der Patenterteilung oder GM-Entragung.

Editor: Müller O.	17-Dec-97	System variables	HMC_V6
Version: a 153589 from 18.12.97		657765.49.03	
File: CHAP_4.DOC	650H0000	Sourcefile:07400102.00J	Page 16 / 47

Proprietary data, company confidential. All rights reserved.
 Contient des informations confidentielles. Tous droits réservés.
 Comunicado como segredo empresarial. Reservados todos os direitos.
 Confidado como secreto industrial. Nos reservamos todos los derechos.

Weitergabe sowie Vervielfältigung dieser Unterlage, Verwertung und Mitteilung ihres Inhalts ist gestattet, soweit nicht ausdrücklich zugestanden. Zuwiderhandlungen verpflichten zu Schadensersatz. Alle Rechte vorbehalten, insbesondere für den Fall der Patenterteilung oder GM-Entragung.

b) Increasing engine speed above nominal idle speed
 ($N_DIF_{(n-3)} \geq N_DIF_{(n)}$ **and** $N_DIF_{(n)} < 0$)

C_N_DIF_CRLC = 1

c) Engine speed below nominal idle speed
 ($N_DIF_{(n)} \geq 0$)

C_N_DIF_CRLC = 0

Remark : Limits of N_DIF_MMV : $C_N_DIF_MIN_MMV \leq N_DIF_MMV \leq 0$

N_DIF_MMV is set to 0 when exiting idle (LV_IS).

Description:

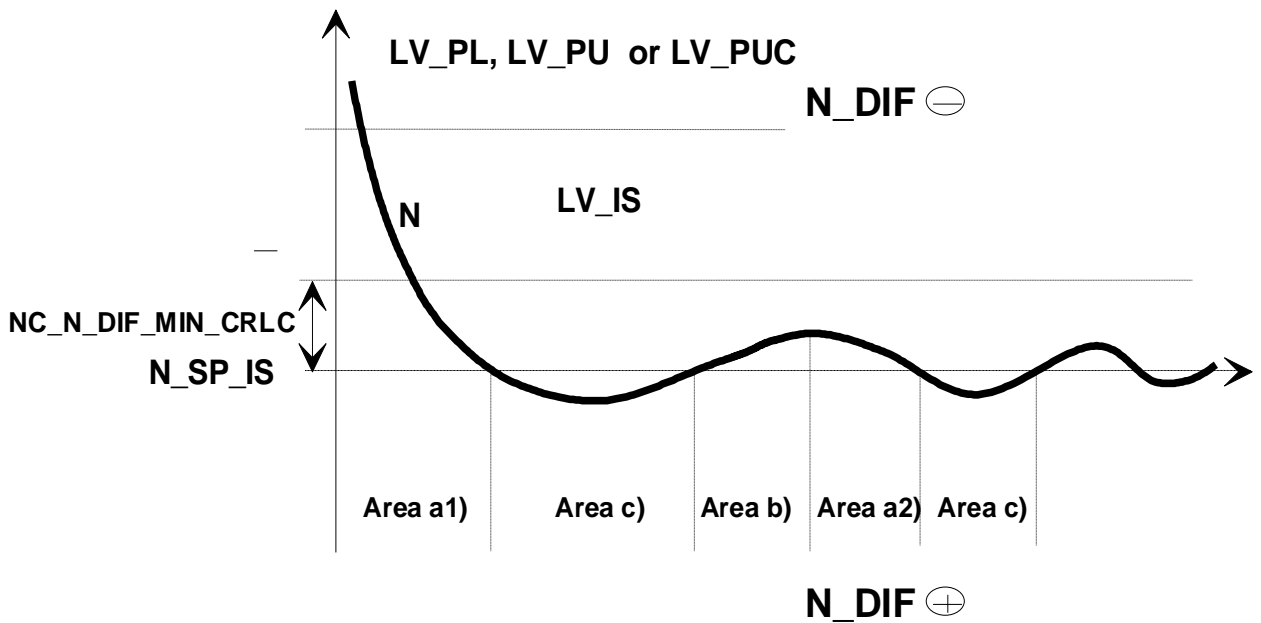

* *N_DIF_COR* calculation :

N_DIF_COR is relevant for the idle controller (idle-charge actuator and ignition timing) :

If $N \leq NC_ISAPWM_N_MAX$

then $N_DIF_COR = N_DIF - N_DIF_MMV * C_N_DIF_FAC$

If $N > NC_ISAPWM_N_MAX$

then $N_DIF_COR = 0$

Editor: Müller O.	17-Dec-97	System variables	HMC_V6
Version: a 153589 from 18.12.97		657765.49.03	
File: CHAP_4.DOC	650H0000	Sourcefile:07400102.00J	Page 17 / 47

Calibration data:

Name	Dim	Hex. limits	Phys. limits	Resol.	Unit
C_N_DIF_CRLC	1	00...FFH	0...0,997	3,895E-3	-
Correlation factor for N_DIF_MMV calculation.					
C_N_DIF_FAC	1	00...FFH	0...0,997	3,895E-3	-
Multiplicative factor for N_DIF_COR calculation.					
C_N_DIF_MIN_MMV	1	F010...0000H	-4080...0	1	rpm
Minimum threshold for N_DIF_MMV limitation.					
NC_N_DIF_MIN_CRLC	1	8000...7FFFH	-32768...32767	1	rpm
Engine speed deviation threshold - Non adjustable calibration.					
NC_ISAPWM_N_MAX	1	0...FFH	0...8160	32	rpm
Maximum engine speed threshold for calculation of N_SP_IS and N_DIF - Non adjustable calibration.					

Applicative Values :

NC_N_DIF_MIN_CRLC = FEB0H = -150 rpm

NC_ISAPWM_N_MAX = 4EH = 2496 rpm

Proprietary data, company confidential. All rights reserved.
 Contine a titre de secret d'entreprise. Tous droits réservés.
 Comunicado como segredo empresarial. Reservados todos os direitos.
 Confidado como secreto industrial. Nos reservamos todos los derechos.

Weitergabe sowie Vervielfältigung dieser Unterlage, Verwertung und Mitteilung ihres Inhalts nicht gestattet, soweit nicht ausdrücklich zugestanden. Zuwiderhandlungen verpflichten zu Schadensersatz. Alle Rechte vorbehalten, insbesondere für den Fall der Patenterteilung oder GM-Eintragung

Editor: Müller O.	17-Dec-97	System variables	HMC_V6
Version: a 153589 from 18.12.97		657765.49.03	
File: CHAP_4.DOC	650H0000	Sourcefile:07400102.00J	Page 18 / 47

1.1.6 Engine running detected during last system run

Output data:

Name	Mode	Hex. limits	Phys. limits	Resol.	Unit
LV_ENG_RUN_IS_PL		0...1H	0...1	1	-
Information bit for engine running detected during last system run					

Input data:

LV_ST	LV_IS	LV_PL	
-------	-------	-------	--

General information:

The bit LV_ENG_RUN_IS_PL is set at the transition from start to idle or partload and is reset at the transition out of powerlatch.

Formula section:

If transition from LV_ST = 1 to LV_IS = 1
or transition from LV_ST = 1 to LV_PL = 1
then LV_ENG_RUN_IS_PL = 1

If Transition out of power latch
then LV_ENG_RUN_IS_PL = 0

Proprietary data, company confidential. All rights reserved. Contine a titre de secret d'entreprise. Tous droits réservés. Comunicado como segredo empresarial. Reservados todos os direitos. Confidado como secreto industrial. Nos reservamos todos los derechos.

Weitergabe sowie Vervielfältigung dieser Unterlage, Wertung und Mitteilung ihres Inhalts nicht gestattet, soweit nicht ausdrücklich zugestanden. Zuwiderhandlungen verpflichten zu Schadenersatz. Alle Rechte vorbehalten, insbesondere für den Fall der Patenterteilung oder GM-Entragung.

Editor: Müller O.	17-Dec-97	System variables	HMC_V6
Version: a 153589 from 18.12.97		657765.49.03	
File: CHAP_4.DOC	650H0000	Sourcefile:07400102.00J	Page 19 / 47

1.2 Mass air flow variables

1.2.1 Calculation of mass air flow correction MAF

Output data:

Name	Mode	Hex. limits	Phys. limits	Resol.	Unit
MAF	V	0...FFFFH	0...1389	0.0212	mg/TDC
Corrected mass air flow.					

Input data:

MAF_MES	N_32	VS	LV_ST
LV_PUR	LV_AE	LV_INF	LV_IS

FUNCTION DESCRIPTION:

General information:

In order to minimize the effect of the transient mode, the measured mass air flow MAF_MES is filtered. The corrected mass air flow is calculated for every engine operating state except start (LV_ST).

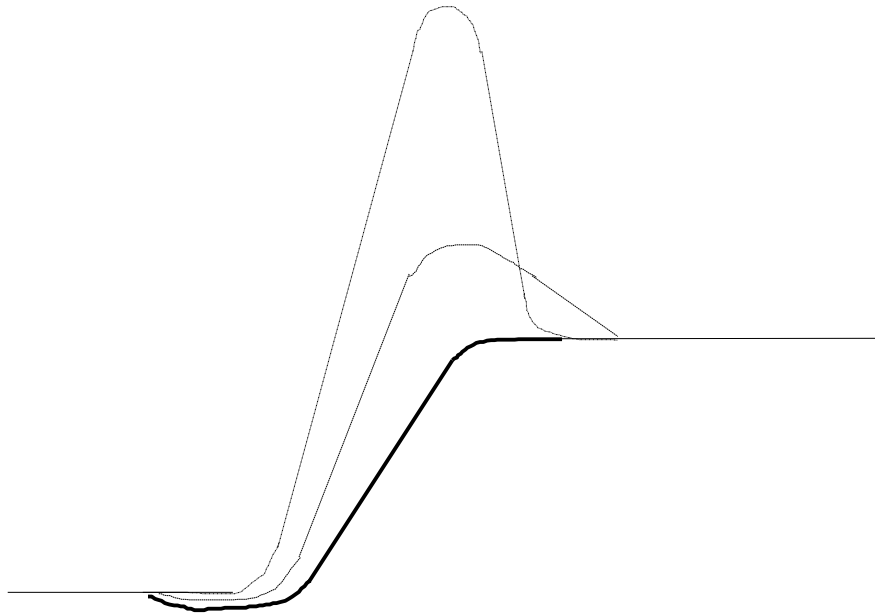

- ..-.-.- : air mass inflow measured
- : induction pipe pressure curve
- - - - : corrected air mass

Editor: Müller O.	17-Dec-97	System variables	HMC_V6
Version: a 153589 from 18.12.97		657765.49.03	
File: CHAP_4.DOC	650H0000	Sourcefile:07400201.001	Page 20 / 47

Proprietary data, company confidential. All rights reserved.
 Contitue a titre de secret d'entreprise. Tous droits réservés.
 Comunicado como segredo empresarial. Reservados todos os direitos.
 Confidado como secreto industrial. Nos reservamos todos los derechos.

Weitergabe sowie Vervielfältigung dieser Unterlage, Verwertung und Mitteilung ihres Inhalts nicht gestattet, soweit nicht ausdrücklich zugestanden. Zuwiderhandlungen verpflichten zu Schadensersatz. Alle Rechte vorbehalten, insbesondere für den Fall der Patenterteilung oder GM-Entragung.

Formula section:

This correction is obtained using an adjustable time filtering factor which depends on the induction tract design and the engine operating state.

$$\text{MAF}_{(n)} = \text{MAF}_{(n-1)} + \text{MAF_CRLC} * (\text{MAF_MES} - \text{MAF}_{(n-1)})$$

The correlation factor MAF_CRLC depends on engine operating states.

Its computation is in accordance with the following algorithm :

- a) **If** trailing throttle fuel reduction is set without acceleration enrichment
(LV_PUR = 1 and LV_AE = 0)

then $\text{MAF_CRLC} = \text{IP_MAF_CRLC_PUR_N_32_MAF_MES}$

else

- b) **If** intercept function is set (LV_INF = 1)

then $\text{MAF_CRLC} = \text{C_MAF_CRLC_INF}$

else

- c) **If** idle speed is set with vehicle stopped (LV_IS = 1 **and** VS = 0)

then $\text{MAF_CRLC} = \text{C_MAF_CRLC_IS}$

else

- d) **If** trailing throttle is set or trailing throttle fuel cut off or idle speed
(LV_PU = 1 **or** LV - PUC = 1 **or** LV_IS = 1)

then $\text{MAF_CRLC} = \text{IP_MAF_CRLC_PU_N_32}$

else

- e) **If** start is set (LS_ST = 1)

then $\text{MAF_CRLC} = 1$

else

$\text{MAF_CRLC} = \text{IP_MAF_CRLC_PL_N_32_MAF_MES}$

Proprietary data, company confidential. All rights reserved.
 Contient des informations confidentielles. Tous droits réservés.
 Comunicado como segredo empresarial. Reservados todos os direitos.
 Confidado como secreto industrial. Nos reservamos todos los derechos.

Weitergabe sowie Vervielfältigung dieser Unterlage, Wertung und Mitteilung ihres Inhalts nicht gestattet, soweit nicht ausdrücklich zugestanden. Zuwiderhandlungen verpflichten zu Schadenersatz. Alle Rechte vorbehalten, insbesondere für den Fall der Patenterteilung oder GM-Entragung.

Editor: Müller O.	17-Dec-97	System variables	HMC_V6
Version: a 153589 from 18.12.97		657765.49.03	
File: CHAP_4.DOC	650H0000	Sourcefile:07400201.001	Page 21 / 47

Calibration data:

Name	Dim	Hex. limits	Phys. limits	Resol.	Unit
IP_MAF_CRLC_PL__N_32__MAF_MES	6x6	0...FFH	0...0.9961	0.0039	-
MAF signal filtering factor triggered in part load.					
IP_MAF_CRLC_PUR__N_32__MAF_MES	4x4	0...FFH	0...0.9961	0.0039	-
MAF signal filtering factor triggered in trailing throttle fuel reduction without acceleration enrichment.					
IP_MAF_CRLC_PU__N_32	4	0...FFH	0...0.9961	0.0039	-
MAF signal filtering factor triggered in trailing throttle or in trailing throttle fuel cut off or in idle with vehicle running.					
C_MAF_CRLC_IS	1	00...FFH	0...0.997	3.895E-3	-
MAF signal filtering factor triggered in idle with vehicle stopped.					
C_MAF_CRLC_INF	1	00...FFH	0...0.997	3.895E-3	-
MAF signal filtering factor triggered for intercept function.					

Proprietary data, company confidential. All rights reserved.
 Contient des données confidentielles de la société. Tous droits réservés.
 Comunicado como secreto empresarial. Reservados todos los derechos.
 Confidado como secreto industrial. Nos reservamos todos los derechos.

Weitergabe sowie Vervielfältigung dieser Unterlage, Wertung und Mitteilung ihres Inhalts nicht gestattet, soweit nicht ausdrücklich zugestanden. Zuwiderhandlungen verpflichten zu Schadensersatz. Alle Rechte vorbehalten, insbesondere für den Fall der Patenterteilung oder GM-Entragung.

Editor: Müller O.	17-Dec-97	System variables	HMC_V6
Version: a 153589 from 18.12.97		657765.49.03	
File: CHAP_4.DOC	650H0000	Sourcefile:07400201.001	Page 22 / 47

1.2.2 Air mass difference for rapidly falling load MAF_MMV, MAF_MMV_DIF

Output data:

Name	Mode	Hex. limits	Phys. limits	Resol.	Unit
MAF_MMV	V	0...FFFFH	0...1389	0.0212	mg/TDC
MAF moving mean value.					
MAF_MMV_DIF	-	0...FFH	0...1389	5.45	mg/TDC
Difference between MAF moving mean value and MAF.					

Input data:

MAF	LV_PL	LV_PU	LV_PUC
-----	-------	-------	--------

FUNCTION DESCRIPTION:

General information:

In the case of rapidly falling load, the transition to trailing throttle fuel cut off can be accelerated in order to avoid an engine speed run-up, which is undesirable.

In order to trigger this function (see the following chapters: ignition, ignition angle correction for trailing throttle) some load conditions have to be fulfilled. For this reason, the values MAF_MMV and MAF_MMV_DIF are calculated from the corrected air mass MAF.

Formula section:

* *MAF_MMV calculation :*

If $MAF_{(n)} \geq MAF_{(n-1)}$ (increasing mass air flow) **then :**

$$MAF_MMV_{(n)} = MAF_{(n)}$$

If $MAF_{(n)} < MAF_{(n-1)}$ (decreasing mass air flow) **then :**

$$MAF_MMV_{(n)} = MAF_MMV_{(n-1)} + (MAF_{(n)} - MAF_MMV_{(n-1)}) * C_MAF_MMV_DIF_CRLC$$

* *MAF_MMV_DIF calculation :*

After transition (LV_PL) -> (LV_PU) :

$$MAF_MMV_DIF_{(n)} = MAF_MMV_{(n)} - MAF_{(n)}$$

Calibration data:

Name	Dim	Hex. limits	Phys. limits	Resol.	Unit
C_MAF_MMV_DIF_CRLC	1	0...FFH	0...0.996	0.0039	-
MAF moving mean value filtering factor.					

Editor: Müller O.	17-Dec-97	System variables	HMC_V6
Version: a 153589 from 18.12.97		657765.49.03	
File: CHAP_4.DOC	650H0000	Sourcefile:07400201.001	Page 23 / 47

Proprietary data, company confidential. All rights reserved. Contine a titre de secret d'entreprise. Tous droits réservés. Comunicado como segredo empresarial. Reservados todos os direitos. Confidado como secreto industrial. Nos reservamos todos los derechos.

Weitergabe sowie Vervielfältigung dieser Unterlage, Wertung und Mitteilung ihres Inhalts nicht gestattet, soweit nicht ausdrücklich zugestanden. Zuwiderhandlungen verpflichten zu Schadensersatz. Alle Rechte vorbehalten, insbesondere für den Fall der Patenterteilung oder GM-Entragung.

1.2.3 Mass air flow ratio calculation MAF_RATIO_PUR, MAF_RATIO_AE

Output data:

Name	Mode	Hex. limits	Phys. limits	Resol.	Unit
MAF_RATIO_PUR	V	00...FFH	0...0.997	3.895E-3	-
Mass air flow ratio for trailing throttle fuel reduction (LV_PUR).					
MAF_RATIO_AE	V	00...FFH	0...0.997	3.895E-3	-
Mass air flow ratio for acceleration enrichment (LV_AE).					

Input data:

MAF	MAF_MES	LV_AE	LV_PUR
-----	---------	-------	--------

FUNCTION DESCRIPTION:

Formula section:

* *MAF_RATIO_PUR calculation for trailing throttle fuel reduction (LV_PUR = 1) :*

MAF_RATIO_PUR is the quotient between the uncorrected mass air flow currently measured and the last corrected mass air flow MAF when trailing throttle fuel reduction was triggered (LV_PUR).

$$\text{MAF_RATIO_PUR} = \text{MAF_MES} / \text{MAF} \text{ when LV_PUR was triggered}$$

* *MAF_RATIO_AE calculation for acceleration enrichment (LV_AE = 1) :*

MAF_RATIO_AE is the quotient between the last corrected mass air flow (MAF) when acceleration enrichment was triggered (LV_AE) and the uncorrected mass air flow currently measured.

$$\text{MAF_RATIO_AE} = \text{MAF} \text{ when LV_AE was triggered} / \text{MAF_MES}$$

Proprietary data, company confidential. All rights reserved. Contine a titre de secret d'entreprise. Tous droits réservés. Comunicado como segredo empresarial. Reservados todos os direitos. Confidado como secreto industrial. Nos reservamos todos los derechos.

Weitergabe sowie Vervielfältigung dieser Unterlage, Verwertung und Mitteilung ihres Inhalts nicht gestattet, soweit nicht ausdrücklich zugestanden. Zuwiderhandlungen verpflichten zu Schadensersatz. Alle Rechte vorbehalten, insbesondere für den Fall der Patenterteilung oder GM-Enttragung

Editor: Müller O.	17-Dec-97	System variables	HMC_V6
Version: a 153589 from 18.12.97		657765.49.03	
File: CHAP_4.DOC	650H0000	Sourcefile:07400201.001	Page 24 / 47

1.2.4 Altitude correction MAF_FAC_ALTI, MAF_ALTI_COR

Output data:

Name	Mode	Hex. limits	Phys. limits	Resol.	Unit
MAF_FAC_ALTI	V	0...FFH	0...1.992	7.78 E-3	-
Mass air flow correction factor for altitude.					
MAF_FAC_ALTI_MMV	V/S	0...FFH	0...1.992	7.78 E-3	-
Moving mean value of mass air flow correction factor for altitude.					
MAF_FAC_ALTI_MMV_CAN	V	0...FFH	0...100	0.392	%
Moving mean value of mass air flow correction factor for altitude distributed via CAN.					
MAF_FAC_ALTI_MAX_PUC	-	0...FFH	0...1.992	7.78 E-3	-
Maximum of mass air flow correction factor for altitude in current PUC-phase.					
MAF_ALTI_COR	V	0...FFH	0...1389	5.4	mg/TDC
Mass air flow corrected versus atmospheric pressure.					

Input data:

MAF_KGH	MAF_KGH_SUB_DIAG	MAF	TCO
LV_MAF_ERR	LV_MAF_PLAUS_ERR	LV_TPS_ERR	LV_TPS_PLAUS_ERR
LV_IV_[CYL]_ERR	LV_ISA_i_ERR	LV_TIA_ERR	LV_WUP
LV_PL	LV_AE	LV_PUC	LV_PUR

FUNCTION DESCRIPTION:

Formula section:

In order to take in account different atmospheric pressures at different altitudes, an altitude correction factor MAF_FAC_ALTI is calculated from division of MAF_KGH by MAF_SUB_DIAG_KGH. MAF_FAC_ALTI_MMV is the filtered value of MAF_FAC_ALTI. The correction factor is calculated in different ways in engine operation state trailing throttle fuel cut-off (LV_PUC = 1) and the other engine operation states, as only an increase of the correction factor is allowed in PUC. The calculation is started after the time C_T_MAF_ALTI_MIN_PUC has elapsed and the MAF_FAC_ALTI-increase is limited during one PUC-phase to C_MAF_FAC_ALTI_DIF_MAX_PUC.

The altitude correction is applied to TIPR_CST, TI_CST and ISAPWM_INI_I_ST during start, to evaporative emission control in MIN- and NORMAL-operation.

MAF_ALTI_COR is the mass air flow corrected to sea level, which is used for ISA-adaptation, ISAPWM-calculation with activated A/C, LAM_TRA-calculation and for the canister-purge conditions (see corresponding chapters).

Editor: Müller O.	17-Dec-97	System variables	HMC_V6
Version: a 153589 from 18.12.97		657765.49.03	
File: CHAP_4.DOC	650H0000	Sourcefile:07400201.001	Page 25 / 47

Proprietary data, company confidential. All rights reserved. Contiene información confidencial. Todos los derechos reservados. Comunicado como secreto empresarial. Reservados todos los derechos. Confidado como secreto industrial. Nos reservamos todos los derechos.

Weitergabe sowie Vervielfältigung dieser Unterlage, Verbreitung und Mitteilung ihres Inhalts nicht gestattet, soweit nicht ausdrücklich zugestanden. Zuwiderhandlungen verpflichten zu Schadenersatz. Alle Rechte vorbehalten, insbesondere für den Fall der Patenterteilung oder GM-Entragung.

Proprietary data, company confidential. All rights reserved. Contine a titre de secret d'entreprise. Tous droits réservés. Comunicado como segredo empresarial. Reservados todos os direitos. Confidado como secreto industrial. Nos reservamos todos los derechos.

Weitergabe sowie Vervielfältigung dieser Unterlage, Verwertung und Mitteilung ihres Inhalts nicht gestattet, soweit nicht ausdrücklich zugestanden. Zuwiderhandlungen verpflichten zu Schadensersatz. Alle Rechte vorbehalten, insbesondere für den Fall der Patenterteilung oder GM-Entragung.

Calculation of MAF_FAC_ALTI:

MAF_FAC_ALTI is calculated in all engine operation states:

$$\text{MAF_FAC_ALTI} = \text{MAF_KGH} / \text{MAF_KGH_SUB_DIAG}$$

Application recurrence : **1 sec.**

Calculation of MAF_FAC_ALTI_MMV :

a.) Out of trailing throttle fuel cut-off (LV_PUC = 0)

- If** MAF > C_MAF_ALTI_MIN
- and** TCO > C_TCO_MAF_ALTI_MIN
- and** TPS > C_TPS_MAF_ALTI_MIN
- and** part load is set without acceleration enrichment, trailing throttle fuel cut-off reduction and out of warm-up
(LV_PL = 1 and LV_PUR = 0 and LV_AE = 0 and LV_WUP= 0)
- and** no error currently present for the mass air flow sensor
(LV_MAF_ERR = 0 and LV_MAF_PLAUS_ERR = 0)
- and** no error currently present for the throttle position sensor
(LV_TPS_ERR = 0 and LV_TPS_PLAUS_ERR = 0)
- and** no error currently present for the injector valves (LV_IV_[CYL]_ERR = 0)
- and** no error currently present for idle charge actuator command
(LV_ISA_i_ERR = 0)
- and** no error currently present for air intake temperature sensor
(LV_TIA_ERR = 0)

then

$$\text{MAF_FAC_ALTI_MMV}_{(n)} = \text{MAF_FAC_ALTI_MMV}_{(n-1)} * (1 - \text{C_MAF_FAC_ALTI_CRLC}) + (\text{MAF_FAC_ALTI} * \text{C_MAF_FAC_ALTI_CRLC})$$

$$\text{MAF_FAC_ALTI_MAX_PUC} = \text{MAF_FAC_ALTI_MMV} + \text{C_MAF_FAC_ALTI_DIF_MAX_PUC}$$

(maximum increase of MAF_FAC_ALTI_MMV in next PUC-phase)

If MAF_FAC_ALTI_MMV < C_MAF_FAC_ALTI_MMV_MIN
then MAF_FAC_ALTI_MMV = C_MAF_FAC_ALTI_MMV_MIN
(Limitation to lower limit)

If MAF_FAC_ALTI_MMV > C_MAF_FAC_ALTI_MMV_MAX
then MAF_FAC_ALTI_MMV = C_MAF_FAC_ALTI_MMV_MAX
(Limitation to upper limit)

Editor: Müller O.	17-Dec-97	System variables	HMC_V6
Version: a 153589 from 18.12.97		657765.49.03	
File: CHAP_4.DOC	650H0000	Sourcefile:07400201.00I	Page 26 / 47

b.) In trailing throttle fuel cut-off (LV_PUC = 1)

If time C_T_MAF_ALTI_MIN_PUC elapsed since transition from PL to PUC
and TCO > C_TCO_MAF_ALTI_MIN
and no error currently present for the mass air flow sensor (LV_MAF_ERR = 0 and LV_MAF_PLAUS_ERR = 0)
and no error currently present for the throttle position sensor (LV_TPS_ERR = 0 and LV_TPS_PLAUS_ERR = 0)
and no error currently present for the injector valves (LV_IV_[CYL]_ERR = 0)
and no error currently present for idle charge actuator command (LV_ISA_i_ERR = 0)
and no error currently present for air intake temperature sensor (LV_TIA_ERR = 0)

then

If (MAF_FAC_ALTI - MAF_FAC_ALTI_MMV) > C_MAF_FAC_ALTI_DIF_MIN_PUC
(Only increasing values are taken in account, i.e. downhill-drive assumed)

then

$$\begin{aligned}
 \text{MAF_FAC_ALTI_MMV}_{(n)} &= \text{MAF_FAC_ALTI_MMV}_{(n-1)} \\
 &\quad * (1 - \text{C_MAF_FAC_ALTI_CRLC}) \\
 &\quad + (\text{MAF_FAC_ALTI} * \text{C_MAF_FAC_ALTI_CRLC})
 \end{aligned}$$

If MAF_FAC_ALTI_MMV > MAF_FAC_ALTI_MAX_PUC
then MAF_FAC_ALTI_MMV = MAF_FAC_ALTI_MAX_PUC
(Limitation for this PUC-phase)

If MAF_FAC_ALTI_MMV > C_MAF_FAC_ALTI_MMV_MAX
then MAF_FAC_ALTI_MMV = C_MAF_FAC_ALTI_MMV_MAX
(Limitation to upper limit)

If MAF_FAC_ALTI_MMV < C_MAF_FAC_ALTI_MMV_MIN
then MAF_FAC_ALTI_MMV = C_MAF_FAC_ALTI_MMV_MIN
(Limitation to lower limit)

Application recurrence : **1 sec.**

MAF_FAC_ALTI_MMV is stored in non-volatile memory. At each new start MAF_FAC_ALTI_MAX_PUC is calculated from the stored value of MAF_FAC_ALTI_MMV. For a new car MAF_FAC_ALTI_MMV is initialised to 1.

Editor: Müller O.	17-Dec-97	System variables	HMC_V6
Version: a 153589 from 18.12.97		657765.49.03	
File: CHAP_4.DOC	650H0000	Sourcefile:07400201.00I	Page 27 / 47

Calculation of MAF_ALTI_COR :

$$\text{MAF_ALTI_COR} = \text{MAF} / \text{MAF_FAC_ALTI_MMV}$$

MAF_ALTI_COR is calculated every **100 msec**, even if the conditions for renewal of MAF_FAC_ALTI_MMV are not fulfilled. In this case the last calculated value MAF_FAC_ALTI_MMV is used.

Calibration data:

Name	Dim	Hex. limits	Phys. limits	Resol.	Unit
C_MAF_ALTI_MIN	1	0...FFFFH	0...1389	0.0212	mg/TDC
MAF-Threshold for calculation of MAF_FAC_ALTI.					
C_TCO_MAF_ALTI_MIN	1	0...FEH	-48...142.5	0.75	°C
TCO-threshold for calculation of MAF_FAC_ALTI.					
C_TPS_MAF_ALTI_MIN	1	0...FF	0...119.5	0.47	°TPS
TPS-threshold for calculation of MAF_FAC_ALTI.					
C_T_MAF_ALTI_MIN_PUC	1	0...FFH	0...255	1	sec
Time delay after which calculation of MAF_FAC_ALTI is allowed in PUC.					
C_MAF_FAC_ALTI_CRLC	1	0...FFH	0...0.997	3.895E-3	-
MAF_FAC_ALTI_MMV filtering factor.					
C_MAF_FAC_ALT_DIF_MAX_PUC	1	0...FFH	0...1.992	7.78 E-3	-
Maximum difference to preceding MAF_FAC_ALTI_MMV -value at entrance in PUC.					
C_MAF_FAC_ALT_DIF_MIN_PUC	1	0...FFH	0...1.992	7.78 E-3	-
Minimum difference between MAF_FAC_ALTI and MAF_FAC_ALTI_MMV to calculate MAF_FAC_ALTI_MMV in PUC.					
C_MAF_FAC_ALTI_MMV_MIN	1	0...FFH	0...1.992	7.78 E-3	-
Lower limit of MAF_FAC_ALTI_MMV.					
C_MAF_FAC_ALTI_MMV_MAX	1	0...FFH	0...1.992	7.78 E-3	-
Upper limit of MAF_FAC_ALTI_MMV.					

Proprietary data, company confidential. All rights reserved.
 Contit a titre de secret d'entreprise. Tous droits réservés.
 Comunicado como segredo empresarial. Reservados todos os direitos.
 Confidado como secreto industrial. Nos reservamos todos los derechos.

Weitergabe sowie Vervielfältigung dieser Unterlage, Verwertung und Mitteilung ihres Inhalts nicht gestattet, soweit nicht ausdrücklich zugestanden. Zuwiderhandlungen verpflichten zu Schadenersatz. Alle Rechte vorbehalten, insbesondere für den Fall der Patenterteilung oder GM-Entragung.

Editor: Müller O.	17-Dec-97	System variables	HMC_V6
Version: a 153589 from 18.12.97		657765.49.03	
File: CHAP_4.DOC	650H0000	Sourcefile:07400201.001	Page 28 / 47

1.3 Throttle angle variables

1.3.1 Throttle potentiometer adaptation TPS_AD_MMV_IS

Output data:

Name	Mode	Hex. limits	Phys. limits	Resol.	Unit
TPS_AD_MMV_IS	V/S	0...FFC0H	0...119,5	0,001825	°TPS
Minimum throttle angle adaptation.					

Input data:

TPS_MES	LV_TPS_ERR	LV_VS_ERR	VS
TPS			

FUNCTION DESCRIPTION:

1.3.1.1 Initialization of throttle potentiometer adaptation

- If the car is "new" or the control unit not previously initialized, the throttle potentiometer adaptation is initialized with the following algorithm :

```

If      TPS_MES < C_TPS_MIN_MAF_KGH_DIAG
then    TPS_AD_MMV_IS(0) = C_TPS_MAX_IS
else    TPS_AD_MMV_IS(0) = TPS_MES + C_TPS_ADD
    
```

- Whenever the control unit is initialized (transition Key OFF->ON and power latch was elapsed):

```

If      TPS_MES > TPS_AD_MMV_IS
then    TPS_AD_MMV_IS(n) = TPS_AD_MMV_IS(n-1) + C_TPS_ADD
else    TPS_AD_MMV_IS(n) = TPS_AD_MMV_IS(n-1)
    
```

Proprietary data, company confidential. All rights reserved. Contine a titre de secret d'entreprise. Tous droits réservés. Comunicado como segredo empresarial. Reservados todos os direitos. Confidado como secreto industrial. Nos reservamos todos los derechos.

Weitergabe sowie Vervielfältigung dieser Unterlage, Verwertung und Mitteilung ihres Inhalts nicht gestattet, soweit nicht ausdrücklich zugestanden. Zuwiderhandlungen verpflichten zu Schadensersatz. Alle Rechte vorbehalten, insbesondere für den Fall der Patenterteilung oder GM-Entragung.

Editor: Müller O.	17-Dec-97	System variables	HMC_V6
Version: a 153589 from 18.12.97		657765.49.03	
File: CHAP_4.DOC	650H0000	Sourcefile:07400301.001	Page 29 / 47

1.3.1.2 Calculation of the throttle potentiometer adaptation TPS_AD_MMV_IS

General information:

The throttle potentiometer adaptation is performed every **1000 ms**.

Formula section:

- General formula for TPS_AD_MMV_IS:

If $TPS < C_TPS_IS$ (LV_CT = 1)
and no error currently present on the throttle position sensor (LV_TPS_ERR = 0)

then $TPS_AD_MMV_IS_{(n)} =$
 $TPS_AD_MMV_IS_{(n-1)} + C_TPS_AD_CRLC * (TPS_MES_{(n)} - TPS_AD_MMV_IS_{(n-1)})$

- Limitation for updating TPS_AD_MMV_IS value:

If $VS = 0$
or Error currently present on vehicle speed (LV_VS_ERR = 1)

then $TPS_AD_MMV_IS_{(n)}$ can not be increased by more than C_TPS_ADD compared to $TPS_AD_MMV_IS_{(n-1)}$

else $TPS_AD_MMV_IS_{(n)}$ can not be increased compared to $TPS_AD_MMV_IS_{(n-1)}$

Remark : (n-1) = adaptation value from last adaptation before conditions of calculation or adaptation value stored up to control unit reset.

- General limitation:

$TPS_AD_MMV_IS \leq C_TPS_MAX_IS$

- TPS_AD_MMV_IS value in case of TPS failure:

If $LV_TPS_ERR = 1$
then $TPS_AD_MMV_IS_{(n)}$ and $TPS_AD_MMV_IS_{(n-1)}$ are set to C_TPS_MAX_IS

Proprietary data, company confidential. All rights reserved.
 Contient a titre de secret d'entreprise. Tous droits réservés.
 Comunicado como segredo empresarial. Reservados todos os direitos.
 Confidado como secreto industrial. Nos reservamos todos los derechos.

Weitergabe sowie Vervielfältigung dieser Unterlage, Verwertung und Mitteilung ihres Inhalts nicht gestattet, soweit nicht ausdrücklich zugestanden. Zuwiderhandlungen verpflichten zu Schadensersatz. Alle Rechte vorbehalten, insbesondere für den Fall der Patenterteilung oder GM-Entragung.

Editor: Müller O.	17-Dec-97	System variables	HMC_V6
Version: a 153589 from 18.12.97		657765.49.03	
File: CHAP_4.DOC	650H0000	Sourcefile:07400301.001	Page 30 / 47

Calibration data:

Name	Dim	Hex. limits	Phys. limits	Resol.	Unit
C_TPS_MIN_MAF_KGH_DIAG	1	0...FFH	0...119,5	0,47	°TPS
TPS-threshold for detection of MAF-signal line short to ground or broken.					
C_TPS_MAX_IS	1	0...FFH	0...119,5	0,47	°TPS
Maximum TPS_AD_MMV_IS value					
C_TPS_ADD	1	0...FFH	0...119,5	0,47	°TPS
Additive offset.					
C_TPS_IS	1	0...FFH	0...119,5	0,47	°TPS
Closed throttle detection threshold.					
C_TPS_AD_CRLC	1	00...FFH	0...0,997	3,895E-3	°TPS
TPS_AD_MMV_IS filtering factor.					

Proprietary data, company confidential. All rights reserved.
 Contitue a titre de secret d'entreprise. Tous droits réservés.
 Comunicado como secreto empresarial. Reservados todos os direitos.
 Confidado como secreto industrial. Nos reservamos todos los derechos.

Weitergabe sowie Vervielfältigung dieser Unterlage, Verwertung und Mitteilung ihres Inhalts nicht gestattet, soweit nicht ausdrücklich zugestanden. Zuwiderhandlungen verpflichten zu Schadensersatz. Alle Rechte vorbehalten, insbesondere für den Fall der Patenterteilung oder GM-Eintragung.

Editor: Müller O.	17-Dec-97	System variables	HMC_V6
Version: a 153589 from 18.12.97		657765.49.03	
File: CHAP_4.DOC	650H0000	Sourcefile:07400301.001	Page 31 / 47

1.3.2 Closed throttle definition LV_CT

Output data:

Name	Mode	Hex. limits	Phys. limits	Resol.	Unit
LV_CT	V	0...01H	0...1	1	-
Closed throttle information.					

Input data:

TPS			
-----	--	--	--

FUNCTION DESCRIPTION:

Formula section:

The closed throttle information LV_CT is defined as follows :

```

If           TPS < C_TPS_IS
then        LV_CT = 1
else        LV_CT = 0
    
```

Proprietary data, company confidential. All rights reserved.
 Contient a titre de secret d'entreprise. Tous droits réservés.
 Comunicado como segredo empresarial. Reservados todos os direitos.
 Confidado como secreto industrial. Nos reservamos todos los derechos.

Weitergabe sowie Vervielfältigung dieser Unterlage, Verwertung und Mitteilung ihres Inhalts nicht gestattet, soweit nicht ausdrücklich zugestanden. Zuwiderhandlungen verpflichten zu Schadensersatz. Alle Rechte vorbehalten, insbesondere für den Fall der Patenterteilung oder GM-Entragung.

Editor: Müller O.	17-Dec-97	System variables	HMC_V6
Version: a 153589 from 18.12.97		657765.49.03	
File: CHAP_4.DOC	650H0000	Sourcefile:07400301.001	Page 32 / 47

1.3.3 Throttle gradient TPS_GRD

Output data:

Name	Mode	Hex. limits	Phys. limits	Resol.	Unit
TPS_GRD	V	FF01...00FFH	- 2988...2988	0,0912	°TPS/sec
Throttle position gradient.					

Input data:

TPS			
-----	--	--	--

FUNCTION DESCRIPTION:

Formula section:

The application recurrence is **10 msec**.

Therefore, the converted throttle values are written into a ring buffer. This means that the last four throttle values are available in addition to the current throttle value.

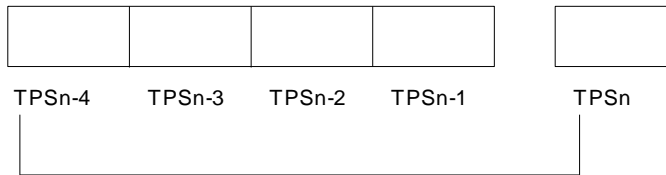

The throttle gradient is based on the change in throttle angle over **40 ms**.

$$TPS_GRD = (TPS_{(n)} - TPS_{(n-4)}) * 25$$

Proprietary data, company confidential. All rights reserved. Contient a titre de secret d'entreprise. Tous droits réservés. Comunicado como segredo empresarial. Reservados todos os direitos. Confidado como secreto industrial. Nos reservamos todos los derechos.

Weitergabe sowie Vervielfältigung dieser Unterlage, Verwertung und Mitteilung ihres Inhalts ist gestattet, soweit nicht ausdrücklich zugestanden. Zuwiderhandlungen verpflichten zu Schadensersatz. Alle Rechte vorbehalten, insbesondere für den Fall der Patenterteilung oder GM-Entragung.

Editor: Müller O.	17-Dec-97	System variables	HMC_V6
Version: a 153589 from 18.12.97		657765.49.03	
File: CHAP_4.DOC	650H0000	Sourcefile:07400301.001	Page 33 / 47

1.3.4 Full load throttle threshold LV_TPS_FL

Output data:

Name	Mode	Hex. limits	Phys. limits	Resol.	Unit
LV_TPS_FL	V	0...01H	0...1	1	-
Full load throttle position information.					

Input data:

TPS			
-----	--	--	--

FUNCTION DESCRIPTION:

Formula section:

Activation conditions:

If $TPS \geq ID_TPS_FL_N_32$
then $LV_TPS_FL = 1$

Deactivation conditions:

If $LV_TPS_FL = 1$ **and** $TPS < ID_TPS_FL_N_32 - C_TPS_HYS_FL$
then $LV_TPS_FL = 0$

Calibration data:

Name	Dim	Hex. limits	Phys. limits	Resol.	Unit
ID_TPS_FL__N_32	16	0...FFH	0...119,5	0,47	°TPS
Throttle position threshold for full load detection.					
C_TPS_HYS_FL	1	0...FFH	0...119,5	0,47	°TPS
Throttle position hysteresis for full load detection.					

Proprietary data, company confidential. All rights reserved. Contine a titre de secret d'entreprise. Tous droits réservés. Comunicado como segredo empresarial. Reservados todos os direitos. Confidado como secreto industrial. Nos reservamos todos los derechos.

Weitergabe sowie Vervielfältigung dieser Unterlage, Verwertung und Mitteilung ihres Inhalts nicht gestattet, soweit nicht ausdrücklich zugestanden. Zuwiderhandlungen verpflichten zu Schadensersatz. Alle Rechte vorbehalten, insbesondere für den Fall der Patenterteilung oder GM-Eintragung

1.4 Vehicle speed variables

1.4.1 Vehicle speed VS

Output data:

Name	Mode	Hex. limits	Phys. limits	Resol.	Unit
VS	V	0...FFH	0...255	1	km/h
Vehicle speed.					
VS_MIN	-	0...FFH	0...255	1	km/h
Minimum vehicle speed to detect vehicle stopped					
VS_MAX	-	0...FFH	0...255	1	km/h
Maximum vehicle speed.					
VS_FAC	-	03E8...7530H	1000...30000	1	Pulse /km
Factor to calculate vehicle speed in km/h					

Input data:

VS_SEG_T_MES	SEG_T_MES_0_RR	CONF_VS	
--------------	----------------	---------	--

FUNCTION DESCRIPTION:

General information:

Application recurrence is **10 msec.**

With the configuration byte CONF_VS, different possibilities of vehicle speed acquisition are configurable (gear box, inductive wheel sensor, ABS/TCS electronic unit). The following variables are automatically adjusted according to CONF_VS:

- VS_MIN : minimum vehicle speed to detect vehicle stopped
- VS_MAX : maximum vehicle speed
- VS_FAC : factor to make the conversion from pulse to km/h

Formula section:

- VS_MIN, VS_MAX, VS_FAC calculation:

```

If          CONF_VS = 0
then       VS_MIN  = C_VS_MIN_0
              VS_MAX  = C_VS_MAX_0
              VS_FAC  = C_VS_FAC_0

else       VS_MIN  = C_VS_MIN_1_2
              VS_MAX  = C_VS_MAX_1_2
              VS_FAC  = C_VS_FAC_1_2
    
```

The calculation is performed once after system reset.

Proprietary data, company confidential. All rights reserved. Contine a titre de secret d'entreprise. Tous droits réservés. Comunicado como segredo empresarial. Reservados todos os direitos. Confidado como secreto industrial. Nos reservamos todos los derechos.

Weitergabe sowie Vervielfältigung dieser Unterlage, Verwertung und Mitteilung ihres Inhalts nicht gestattet, soweit nicht ausdrücklich zugestanden. Zuwiderhandlungen verpflichten zu Schadenersatz. Alle Rechte vorbehalten, insbesondere für den Fall der Patenterteilung oder GM-Entragung.

Editor: Müller O.	17-Dec-97	System variables	HMC_V6
Version: a 153589 from 18.12.97		657765.49.03	
File: CHAP_4.DOC	650H0000	Sourcefile:07400402.00H	Page 35 / 47

Proprietary data, company confidential. All rights reserved. Contine a titre de secret d'entreprise. Tous droits réservés. Comunicado como segredo empresarial. Reservados todos os direitos. Confidado como secreto industrial. Nos reservamos todos los derechos.

Weitergabe sowie Vervielfältigung dieser Unterlage, Verwertung und Mitteilung ihres Inhalts nicht gestattet, soweit nicht ausdrücklich zugestanden. Zuwiderhandlungen verpflichten zu Schadenersatz. Alle Rechte vorbehalten, insbesondere für den Fall der Patenterteilung oder GM-Entragung

- VS_SEG_T_MES and SEG_T_MES_0_RR definition :

VS_SEG_T_MES is used in case of signal coming from the Gearbox (CONF_VS=0). It is the time for 1 teeth averaged over 4 last tooth.

SEG_T_MES_0_RR is used in case of signal coming from the Wheel (CONF_VS=1 or 2). It is the time for 4 tooth.

(Time resolution is 4 µsec)

- VS calculation :

If CONF_VS = 0
then $VS = (3600 * 10^6) / (VS_FAC * VS_SEG_T_MES)$

else
 $VS = (900 * 10^6) / (VS_FAC * SEG_T_MES_0_RR)$

(VS is set to 0 is VS < VS_MIN)

Calibration data:

Name	Dim	Hex. limits	Phys. limits	Resol.	Unit
C_VS_MIN_0	1	0...FFH	0...255	1	km/h
Minimum Vehicle speed for Vehicle Stop Detection if CONF_VS = 0					
C_VS_MIN_1_2	1	0...FFH	0...255	1	km/h
Minimum Vehicle speed for Vehicle Stop Detection if CONF_VS = 1 or 2					
C_VS_MAX_0	1	0...FFH	0...255	1	km/h
Maximum Vehicle speed if CONF_VS = 0					
C_VS_MAX_1_2	1	0...FFH	0...255	1	km/h
Maximum Vehicle speed if CONF_VS = 1 or 2					
C_VS_FAC_0	1	03E8...7530H	1000...30000	1	Pulse/km
Number of Pulses/km which appear on the ECU Input if CONF_VS = 0					
C_VS_FAC_1_2	1	03E8...7530H	1000...30000	1	Pulse/km
Number of Pulses/km which appear on the ECU Input if CONF_VS = 1 or 2					

Editor: Müller O.	17-Dec-97	System variables	HMC_V6
Version: a 153589 from 18.12.97		657765.49.03	
File: CHAP_4.DOC	650H0000	Sourcefile:07400402.00H	Page 36 / 47

1.4.2 Vehicle speed for rough road detection VS_RR

Output data:

Name	Mode	Hex. limits	Phys. limits	Resol.	Unit
VS_RR	1	0...FFH	0...255	1	km/h
Vehicle speed used for rough road detection.					

Input data:

CONF_MIS	VS	
----------	----	--

FUNCTION DESCRIPTION:

General information:

Application recurrence is **10 msec.**

Formula section:

If CONF_MIS = 1
then VS_RR = VS
else VS_RR = 0

Proprietary data, company confidential. All rights reserved.
 Contient a titre de secret d'entreprise. Tous droits réservés.
 Comunicado como segredo empresarial. Reservados todos os direitos.
 Confidado como secreto industrial. Nos reservamos todos los derechos.

Weitergabe sowie Vervielfältigung dieser Unterlage, Verwertung und Mitteilung ihres Inhalts nicht gestattet, soweit nicht ausdrücklich zugestanden. Zuwiderhandlungen verpflichten zu Schadensersatz. Alle Rechte vorbehalten, insbesondere für den Fall der Patenterteilung oder GM-Entragung.

Editor: Müller O.	17-Dec-97	System variables	HMC_V6
Version: a 153589 from 18.12.97		657765.49.03	
File: CHAP_4.DOC	650H0000	Sourcefile:07400402.00H	Page 37 / 47

1.4.3 Vehicle speed state VS_STATE_CFA

Output data:

Name	Mode	Hex. limits	Phys. limits	Resol.	Unit
VS_STATE_CFA	V	0...02H	0...2	1	-
Vehicle speed state for cooling fans.					

Input data:

VS	LV_ACCIN	LV_VS_ERR	
----	----------	-----------	--

FUNCTION DESCRIPTION:

General information:

The fans are controlled according to the vehicle speed. For this purpose, a vehicle speed state is determined. The vehicle speed thresholds are different if the air conditioner is selected or not.

Formula section:

Initialization:

At ECU initialization, VS_STATE_CFA is set to 0.

Calculation :

* LV_ACCIN = 0

If (VS_STATE_CFA = 0 **and** VS > C_VS_2_CFA)

then VS_STATE_CFA = 1

If (VS_STATE_CFA = 1 **and** VS < C_VS_2_CFA - C_VS_HYS_1_CFA)

then VS_STATE_CFA = 0

* LV_ACCIN = 1

If (VS_STATE_CFA = 0 **and** VS > C_VS_1_CFA)

then VS_STATE_CFA = 1

If (VS_STATE_CFA = 1 **and** VS < C_VS_1_CFA - C_VS_HYS_1_CFA)

then VS_STATE_CFA = 0

* Independently of LV_ACCIN

If (VS_STATE_CFA = 1 **and** VS > C_VS_3_CFA)

then VS_STATE_CFA = 2

If (VS_STATE_CFA = 2 **and** VS < C_VS_3_CFA - C_VS_HYS_2_CFA)

then VS_STATE_CFA = 1

Remark : C_VS_1_CFA < C_VS_2_CFA < C_VS_3_CFA

Proprietary data, company confidential. All rights reserved. Contine a titre de secret d'entreprise. Tous droits réservés. Comunicado como segredo empresarial. Reservados todos os direitos. Confidado como secreto industrial. Nos reservamos todos los derechos.

Weitergabe sowie Vervielfältigung dieser Unterlage, Verwertung und Mitteilung ihres Inhalts nicht gestattet, soweit nicht ausdrücklich zugestanden. Zuwiderhandlungen verpflichten zu Schadensersatz. Alle Rechte vorbehalten, insbesondere für den Fall der Patenterteilung oder GM-Entragung.

Editor: Müller O.	17-Dec-97	System variables	HMC_V6
Version: a 153589 from 18.12.97		657765.49.03	
File: CHAP_4.DOC	650H0000	Sourcefile:07400402.00H	Page 38 / 47

Limp Home :

If LV_VS_ERR = 1 *(Error currently present on vehicle speed sensor)*
then VS_STATE_CFA = 0

Calibration data:

Name	Dim	Hex. limits	Phys. limits	Resol.	Unit
C_VS_1_CFA	1	0...FFH	0...255	1	km/h
Vehicle speed threshold for fans management.					
C_VS_2_CFA	1	0...FFH	0...255	1	km/h
Vehicle speed threshold for fans management.					
C_VS_3_CFA	1	0...FFH	0...255	1	km/h
Vehicle speed threshold for fans management.					
C_VS_HYS_1_CFA	1	0...FFH	0...255	1	km/h
Vehicle speed hysteresis for VS_STATE_CFA transition 1 -> 0.					
C_VS_HYS_2_CFA	1	0...FFH	0...255	1	km/h
Vehicle speed hysteresis for VS_STATE_CFA transition 2 -> 1.					

Proprietary data, company confidential. All rights reserved.
 Contit a titre de secret d'entreprise. Tous droits réservés.
 Comunicado como segredo empresarial. Reservados todos os direitos.
 Confidado como secreto industrial. Nos reservamos todos los derechos.

Weitergabe sowie Vervielfältigung dieser Unterlage, Verwertung und Mitteilung ihres Inhalts nicht gestattet, soweit nicht ausdrücklich zugestanden. Zuwiderhandlungen verpflichten zu Schadensersatz. Alle Rechte vorbehalten, insbesondere für den Fall der Patenterteilung oder GM-Eintragung

Editor: Müller O.	17-Dec-97	System variables	HMC_V6
Version: a 153589 from 18.12.97		657765.49.03	
File: CHAP_4.DOC	650H0000	Sourcefile:07400402.00H	Page 39 / 47

1.5 Coolant temperature variables

1.5.1 Coolant temperature TCO

Output data:

Name	Mode	Hex. limits	Phys. limits	Resol.	Unit
TCO	V	0...FEH	-48...142,5	0,75	°C
Coolant temperature.					

Input data:

TCO_MES			
---------	--	--	--

FUNCTION DESCRIPTION:

General information:

The temperature TCO_MES is monitored for unplausible gradient.

TCO = TCO_MES

Exception :

The difference between the old and the new TCO_MES value exceeds the permissible gradient C_TCO_GRD_MAX_DIAG, then the TCO value remains unchanged.

During the next measurement, if the maximum gradient is exceeded again, the new measured value will be stored in the RAM.

Errors are not stored with the monitoring of gradients. The only purpose is to extract implausible measured values (malfunctions).

Calibration data:

Name	Dim	Hex. limits	Phys. limits	Resol.	Unit
C_TCO_GRD_MAX_DIAG	1	0...FEH	0...190,5	0,75	°C/500msec
Maximum coolant temperature gradient for diagnostic.					

Proprietary data, company confidential. All rights reserved. Contient des informations confidentielles. Tous droits réservés. Comunicado como segredo empresarial. Reservados todos os direitos. Confidado como secreto industrial. Nos reservamos todos los derechos.

Weitergabe sowie Vervielfältigung dieser Unterlage, Verwertung und Mitteilung ihres Inhalts ist gestattet, soweit nicht ausdrücklich zugestanden. Zuwiderhandlungen verpflichten zu Schadenersatz. Alle Rechte vorbehalten, insbesondere für den Fall der Patenterteilung oder GM-Entragung.

Editor: Müller O.	17-Dec-97	System variables	HMC_V6
Version: a 153589 from 18.12.97		657765.49.03	
File: CHAP_4.DOC	650H0000	Sourcefile:07400601.00D	Page 40 / 47

1.5.2 Coolant temperature at start TCO_ST

Output data:

Name	Mode	Hex. limits	Phys. limits	Resol.	Unit
TCO_ST	V/S	0...FEH	-48...142,5	0,75	°C
Coolant temperature at engine operating state start (LV_ST).					

Input data:

TCO	LV_ST		
-----	-------	--	--

TCO_ST is the coolant temperature at the time of transition from engine stop (LV_ES) to start (LV_ST). It is updated with the current TCO-value as long as the engine operation state start (LV_ST) is not exited to idle or part load.

Proprietary data, company confidential. All rights reserved. Contine a titre de secret d'entreprise. Tous droits réservés. Comunicado como segredo empresarial. Reservados todos os direitos. Confidado como secreto industrial. Nos reservamos todos los derechos.

Weitergabe sowie Vervielfältigung dieser Unterlage, Wertung und Mitteilung ihres Inhalts nicht gestattet, soweit nicht ausdrücklich zugestanden. Zuwiderhandlungen verpflichten zu Schadensersatz. Alle Rechte vorbehalten, insbesondere für den Fall der Patenterteilung oder GM-Eintragung.

Editor: Müller O.	17-Dec-97	System variables	HMC_V6
Version: a 153589 from 18.12.97		657765.49.03	
File: CHAP_4.DOC	650H0000	Sourcefile:07400601.00D	Page 41 / 47

1.5.3 Coolant temperature at re-start TCO_REST

Output data:

Name	Mode	Hex. limits	Phys. limits	Resol.	Unit
TCO_REST	V/S	0...FEH	-48...142,5	0,75	°C
Coolant temperature stored to detect a re-start event.					

Input data:

TCO	N	LV_ES	IP_N_MAX_TOL_ST_TCO
-----	---	-------	---------------------

FUNCTION DESCRIPTION:

General information:

A timer is started when $N \geq IP_N_MAX_TOL_ST_TCO$.

If the engine operating state engine stopped (LV_ES) is detected after idle or part load before the timer has reached it's maximum value C_T_MAX_REST, the related coolant temperature is stored :

$$TCO_REST \leftarrow TCO$$

Instead if the engine operating state engine stopped (LV_ES) is detected after the timer has reached it's maximum, FFH is stored. If the engine stalls before N is exceeding IP_N_MAX_TOL_ST_TCO FFH is stored also.

TCO_REST is used as input for the restart-detection function.

Calibration data:

Name	Type	Dim	Hex. limits	Phys. limits	Resol.	Unit
C_T_MAX_REST	2U	1	1...FFFFH	0,01...655,35	0,01	sec
Duration between LV_IS and LV_ES, to detect LV_REST.						

Proprietary data, company confidential. All rights reserved. Contine a titre de secret d'entreprise. Tous droits réservés. Comunicado como segredo empresarial. Reservados todos os direitos. Confidado como secreto industrial. Nos reservamos todos los derechos.

Weitergabe sowie Vervielfältigung dieser Unterlage, Verbreitung und Mitteilung ihres Inhalts nicht gestattet, soweit nicht ausdrücklich zugestanden. Zuwiderhandlungen verpflichten zu Schadenersatz. Alle Rechte vorbehalten, insbesondere für den Fall der Patenterteilung oder GM-Entragung.

Editor: Müller O.	17-Dec-97	System variables	HMC_V6
Version: a 153589 from 18.12.97		657765.49.03	
File: CHAP_4.DOC	650H0000	Sourcefile:07400601.00D	Page 42 / 47

1.6 Intake Air Temperature Variable TIA

Output data:

Name	Mode	Hex. limits	Phys. limits	Resol.	Unit
TIA	V	0...FEH	-48...142,5	0,75	°C
Induction air temperature					

Input data:

TIA_MES		
---------	--	--

FUNCTION DESCRIPTION:

General information:

The temperature TIA_MES is monitored for unplausible gradient.

TIA = TIA_MES

Except if :

The difference between the old and the new TIA_MES value exceeds the permissible gradient C_TIA_GRD_MAX_DIAG, then the TIA value remains unchanged.

During the next measurement, if the maximum gradient is exceeded again, the new measured value will be stored in the RAM.

Errors are not stored with the monitoring of gradients. The only purpose is to extract implausible measured values (malfunctions).

Calibration data:

Name	Dim	Hex. limits	Phys. limits	Resol.	Unit
C_TIA_GRD_MAX_DIAG	1	0...FEH	0...190,5	0,75	°C/500msec
Maximum induction air temperature gradient for diagnostic.					

Proprietary data, company confidential. All rights reserved. Contient des informations confidentielles. Tous droits réservés. Comunicado como segredo empresarial. Reservados todos os direitos. Confidado como secreto industrial. Nos reservamos todos los derechos.

Weitergabe sowie Vervielfältigung dieser Unterlage, Verwertung und Mitteilung ihres Inhalts ist gestattet, soweit nicht ausdrücklich zugestanden. Zuwiderhandlungen verpflichten zu Schadenersatz. Alle Rechte vorbehalten, insbesondere für den Fall der Patenterteilung oder GM-Entragung.

Editor: Müller O.	17-Dec-97	System variables	HMC_V6
Version: a 153589 from 18.12.97		657765.49.03	
File: CHAP_4.DOC	650H0000	Sourcefile:07400701.00C	Page 43 / 47

1.6.1 Intake Air Temperature at Start TIA_ST

Output data:

Name	Mode	Hex. limits	Phys. limits	Resol.	Unit
TIA_ST	V	0...FEH	-48...142,5	0,75	°C
Intake Air Temperature at engine operating state start (LV_ST).					

Input data:

TIA	LV_ST		
-----	-------	--	--

TIA_ST is the Intake Air Temperature at the time of transition from engine stop (LV_ES) to start (LV_ST).

Proprietary data, company confidential. All rights reserved.
 Contient des informations confidentielles de la société. Tous droits réservés.
 Comunicado como segredo empresarial. Reservados todos os direitos.
 Confidado como secreto industrial. Nos reservamos todos los derechos.

Weitergabe sowie Vervielfältigung dieser Unterlage, Verwertung und Mitteilung ihres Inhalts ist gestattet, soweit nicht ausdrücklich zugestanden. Zuwiderhandlungen verpflichten zu Schadensersatz. Alle Rechte vorbehalten, insbesondere für den Fall der Patenterteilung oder GM-Eintragung.

Editor: Müller O.	17-Dec-97	System variables	HMC_V6
Version: a 153589 from 18.12.97		657765.49.03	
File: CHAP_4.DOC	650H0000	Sourcefile:07400701.00C	Page 44 / 47

1.7 Gear ratio

Output data:

Name	Mode	Hex. limits	Phys. limits	Resol.	Unit
GR_MT	V	0...5H	0...5	1	-
Gear Ratio for MT vehicle					

Input data:

CONF_TCU	CRK_VS_RR_N_RATIO_OSC	LV_VS_ERR	LV_CRK_ERR
VS			

FUNCTION DESCRIPTION:

General information:

In order to improve driveability with MT vehicle, engaged gear ratio detection is needed for various functions :

- Minimum engine speed for fuel cut-off
- Activation for injection pattern at rewetting

Formula section:

```

If CONF_TCU = 0
    and LV_VS_ERR = 0
    and LV_CRK_ERR = 0
    and VS > 0
Then
    GR_MT = ID_GR_MT__CRK_VS_RR_N_RATIO_OSC
Else
    GR_MT = 0
    
```

Calibration data:

Name	Dim	Hex. limits	Phys. limits	Resol.	Unit
ID_GR_MT	6	00...05H	0...5	1	-
Gear ratio determination					

Proprietary data, company confidential. All rights reserved. Contine a titre de secret d'entreprise. Tous droits réservés. Comunicado como segredo empresarial. Reservados todos os direitos. Confidado como secreto industrial. Nos reservamos todos los derechos.

Weitergabe sowie Vervielfältigung dieser Unterlage, Verwertung und Mitteilung ihres Inhalts nicht gestattet, soweit nicht ausdrücklich zugestanden. Zuwiderhandlungen verpflichten zu Schadenersatz. Alle Rechte vorbehalten, insbesondere für den Fall der Patenterteilung oder GM-Eintragung

1.8 Idle speed actuator variables

1.8.1 Time delay to apply drive correction

Output data:

Name	Mode	Hex. limits	Phys. limits	Resol.	Unit
LV_DRI_ISAPWM	V	0..01H	0..1	1	-
Boolean for DRIVE or REVERSE engaged (- / DRI) with time delay applied.					

Input data:

LV_DRI			
--------	--	--	--

FUNCTION DESCRIPTION:

Engagement of DRIVE:

At transition from PARK/NEUTRAL to DRIVE (LV_DRI changes from 0 to 1) LV_DRI_ISAPWM is changed in the same way as LV_DRI after the time delay IP_T_DLY_ISAPWM_DRI_INC_TCO has elapsed. In opposite direction, i.e. at transition from DRIVE to PARK/NEUTRAL (LV_DRI changes from 1 to 0), LV_DRI_ISAPWM is also changed like LV_DRI after IP_T_DLY_ISAPWM_DRI_DEC_TCO has elapsed.

These time delays are used to counteract the temperature influence of the converter, which locks the clutch when the DRIVE position is engaged.

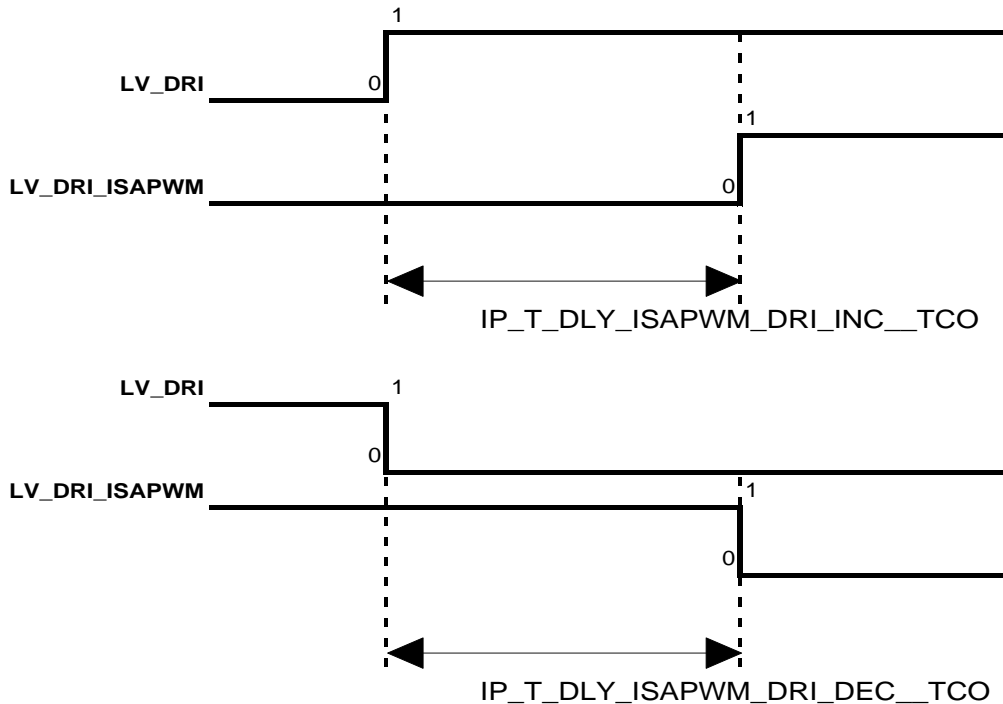

Proprietary data, company confidential. All rights reserved. Contine a titre de secret d'entreprise. Tous droits réservés. Comunicado como segredo empresarial. Reservados todos os direitos. Confidado como secreto industrial. Nos reservamos todos los derechos.

Weitergabe sowie Vervielfältigung dieser Unterlage, Verwertung und Mitteilung ihres Inhalts nicht gestattet, soweit nicht ausdrücklich zugestanden. Zuwiderhandlungen verpflichten zu Schadensersatz. Alle Rechte vorbehalten, insbesondere für den Fall der Patenterteilung oder GM-Enttragung.

Editor: Müller O.	17-Dec-97	System variables	HMC_V6
Version: a 153589 from 18.12.97		657765.49.03	
File: CHAP_4.DOC	650H0000	Sourcefile:07401H01.00A	Page 46 / 47

Engagement of REVERSE:

At transition from PARK/NEUTRAL to REVERSE additional to the time delay IP_T_DLY_ISAPWM_DRI_INC_TCO for engaging DRIVE the time delay C_T_DLY_ISAPWM_DRI_INC has to be ellapsed before LV_DRI_ISAPWM is changed in the same way as LV_DRI:

$$IP_T_DLY_ISAPWM_DRI_INC_TCO + C_T_DLY_ISAPWM_RVS_INC$$

In opposite direction, i.e. at transition from REVERSE to PARK/NEUTRAL, LV_DRI_ISAPWM is changed like LV_DRI after IP_T_DLY_ISAPWM_DRI_DEC_TCO + C_T_DLY_ISAPWM_DRI_DEC has ellapsed.

$$IP_T_DLY_ISAPWM_DRI_DEC_TCO + C_T_DLY_ISAPWM_RVS_DEC$$

Calibration data:

Name	Dim	Hex. limits	Phys. limits	Resol.	Unit
C_T_DLY_ISAPWM_RVS_INC	1	0...FFH	-1.27...1.28	10	msec
Additional time delay to apply Idle charge - actuator opening increase at engage of REVERSE.					
C_T_DLY_ISAPWM_RVS_DEC	1	0...FFH	-1.27...1.28	10	msec
Additional time delay to apply Idle charge - actuator opening decrease at disengage of REVERSE.					
IP_T_DLY_ISAPWM_DRI_INC_TCO	6	0...FFH	0...2.55	10	msec
Time delay to apply Idle charge - actuator opening increase at engage of DRIVE.					
IP_T_DLY_ISAPWM_DRI_DEC_TCO	6	0...FFH	0...2.55	10	msec
Time delay to apply Idle charge - actuator opening decrease at disengage of DRIVE.					

Proprietary data, company confidential. All rights reserved. Contine a titre de secret d'entreprise. Tous droits réservés. Comunicado como segredo empresarial. Reservados todos os direitos. Confidado como secreto industrial. Nos reservamos todos los derechos.

Weitergabe sowie Vervielfältigung dieser Unterlage, Verwertung und Mitteilung ihres Inhalts nicht gestattet, soweit nicht ausdrücklich zugestanden. Zuwiderhandlungen verpflichten zu Schadensersatz. Alle Rechte vorbehalten, insbesondere für den Fall der Patenterteilung oder GM-Entragung.

Editor: Müller O.	17-Dec-97	System variables	HMC_V6
Version: a 153589 from 18.12.97		657765.49.03	
File: CHAP_4.DOC	650H0000	Sourcefile:07401H01.00A	Page 47 / 47

Document: **Engine operating states**

Project: **Engine Management System**
HMC_V6

Version: a

Date: 17-Dec-97

Number of pages: 43

Revision Code-No.: 153589 from 18.12.97

Construction protocol-No.:

Software version: 650H0000

	Name	Department	Phone	Date	Sign
Author	Müller O.	AT PT SI TSA 11	3211	09.12.97	
1. Check	Pioch O.	AT PT SI TSA 11	3212	09.12.97	
2. Check	Gessner S.	AT PT SI TSA 11	5398	09.12.97	
Responsible	Brückner D.	AT PT SI TSA 16	4279	09.12.97	

Version list

Proprietary data, company confidential. All rights reserved. Contine a titre de secret d'entreprise. Tous droits réservés. Comunicado como segredo empresarial. Reservados todos os direitos. Confidado como secreto industrial. Nos reservamos todos los derechos.

Weitergabe sowie Vervielfältigung dieser Unterlage, Wertung und Mitteilung ihres Inhalts nicht gestattet, soweit nicht ausdrücklich zugestanden. Zuwiderhandlungen verpflichten zu Schadensersatz. Alle Rechte vorbehalten, insbesondere für den Fall der Patenterteilung oder GM-Eintragung

Version	Date	Author	Comment, Description

Editor:	Müller O.	17-Dec-97	Engine operating states	HMC_V6
Version:	a 153589 from 18.12.97		657765.49.04	
File:	CHAP_5.DOC	650H0000		Page 2 / 43

Table of contents

Page

1.1	General	9
1.1.1	Engine operating state detection	9
1.1.2	Power Latch	9
1.1.2.1	Function initialization	11
1.1.2.2	Reset with the system running	11
1.1.3	Engine operating state " Engine Stopped " (LV_ES)	12
1.2	Basic Operating States : LV_ST, LV_IS, LV_PL, LV_PU, LV_PUC	13
1.2.1	Engine operating state : " Start " (LV_ST)	13
1.2.2	Engine operating state : " Idle Speed " (LV_IS)	14
1.2.3	Engine operating state : " Part Load " (LV_PL)	15
1.2.4	Engine operating state : " Trailing Throttle " (LV_PU)	17
1.2.5	Engine operating state : " Trailing Throttle Fuel Cut Off " (LV_PUC)	19
1.3	Basic functions : LV_FL, LV_AE, LV_PUR, LV_INF, LV_REAC	22
1.3.1	Full Load (LV_FL)	22
1.3.2	Acceleration Enrichment (LV_AE)	24
1.3.3	Trailing Throttle Fuel Reduction (LV_PUR)	26
1.3.4	Intercept function (LV_INF)	28
1.3.5	Re-start fuel feed function (LV_REAC)	30
1.4	Auxiliary functions	31
1.4.1	Start break-off detection (LV_ST_ES)	31
1.4.2	Restart detection function (LV_REST)	33
1.4.3	Post - Start function (LV_TI_AST, LV_IGA_AST)	36
1.4.4	Warm - Up function (LV_WUP)	37
1.4.5	Rich mixture Warm - Up (LV_RWUP)	38
1.4.6	Catalyst Heating functions (LV_IGA_CH, LV_TI_CH, LV_N_SP_ADD_CH)	40
1.5	General Drawing	43

Proprietary data, company confidential. All rights reserved.
 Contient des données confidentielles. Tous droits réservés.
 Comunicado como secreto empresarial. Reservados todos los derechos.
 Confiado como secreto industrial. Nos reservamos todos los derechos.

Weitergabe sowie Vervielfältigung dieser Unterlage, Verwertung und Mitteilung ihres Inhalts ist gestattet, soweit nicht ausdrücklich zugestanden. Zuwiderhandlungen verpflichten zu Schadenersatz. Alle Rechte vorbehalten, insbesondere für den Fall der Patenterteilung oder GM-Enttragung.

Editor:	Müller O.	17-Dec-97	Engine operating states	HMC_V6
Version:	a 153589 from 18.12.97		657765.49.04	
File:	CHAP_5.DOC	650H0000		Page 3 / 43

Index	Page
C	
C_CYCNR_HYS_PUC	
def.....	21
C_CYCNR_HYS_PUC_ST	
def.....	21
C_IGA_VS_MAX_CH	
def.....	42
C_ISAPWM_LGRD_D	
use.....	28
C_MAF_MMV_DIF_MIN_PU	
def.....	16
C_N_GRD_MIN	
def.....	18
use.....	19, 28
C_N_GRD_MIN_D	
def.....	21
use.....	28
C_N_GRD_MIN_PU	
def.....	16
C_N_HYS_MAX_PUC	
def.....	21
C_N_HYS_MIN_PUC	
def.....	21
C_N_HYS_PUC_ST	
def.....	21
C_N_MAX_BOL_ST	
def.....	14
use.....	15
C_N_MAX_INF	
def.....	18
use.....	19, 28
C_N_MIN_FL	
def.....	23
C_N_MIN_LGRD_PU	
def.....	16
C_N_MIN_PUC_DIAG	
def.....	21
C_N_SP_T_CH	
def.....	42
C_T_MAX_DLY_ECU	
def.....	10
C_T_MAX_ECU	
def.....	10
use.....	31, 33
C_T_MIN_D_ISA	
def.....	29
C_T_MIN_ECU_REST	
def.....	32
use.....	33
C_T_ON_RWUP	
def.....	39
C_T_ON_RWUP_IS	

Editor: Müller O.	17-Dec-97	Engine operating states	HMC_V6
Version: a 153589 from 18.12.97		657765.49.04	
File: CHAP_5.DOC	650H0000	Page 4 / 43	

def.....	39
C_TCO_DIF_MAX_REST	
def.....	35
C_TCO_DRI_MIN_AE	
def.....	25
C_TCO_MIN_FL	
def.....	23
C_TCO_MIN_PU	
def.....	16
C_TCO_MIN_PUC_ST	
def.....	21
C_TPS_GRD_ADD_DIAG	
def.....	25
use.....	26
C_TPS_GRD_MIN_PU	
def.....	16
C_TPS_HYS_FL	
use.....	22
C_VS_MIN_FL	
def.....	23
CYCNR_ES_ST	
def.....	13
use.....	31, 33
CYCNR_ST_AST	
def.....	36
I	
ID_IGA_T_CH_TCO_ST	
def.....	42
ID_N_SP_T_CH_TCO_ST	
def.....	42
ID_TI_T_CH_TCO_ST	
def.....	42
ID_TPS_FL_N_32	
use.....	22
ID_TPS_GRD_ADD_AE(_AT)_TCO	
def.....	25
ID_TPS_GRD_ADD_PUR(_AT)_TCO	
def.....	27
ID_TPS_GRD_BOL_AE(_AT)_N_32_TPS	
def.....	25
ID_TPS_GRD_BOL_PUR(_AT)_N_32_TPS	
def.....	27
IGA_DYN_COR_IS	
use.....	36
IGA_PU_PUC	
use.....	17
IP_MAF_MMV_MIN_PU_N_32	
def.....	16
IP_N_ACCIN_MIN_PUC_TCO_GR_MT	
def.....	18
use.....	19
IP_N_MAX_TOL_ST_TCO	
def.....	13
use.....	11, 31
IP_N_MIN_PUC_TCO_GR_MT	
def.....	18

Editor: Müller O.	17-Dec-97	Engine operating states	HMC_V6
Version: a 153589 from 18.12.97		657765.49.04	
File: CHAP_5.DOC	650H0000		Page 5 / 43

Proprietary data, company confidential. All rights reserved.
 Contine a titre de secret d'entreprise. Tous droits réservés.
 Comunicado como segredo empresarial. Reservados todos os direitos.
 Confidado como secreto industrial. Nos reservamos todos los derechos.

Weitergabe sowie Vervielfältigung dieser Unterlage, Verwertung und Mitteilung ihres Inhalts nicht gestattet, soweit nicht ausdrücklich zugestanden. Zuwiderhandlungen verpflichten zu Schadenersatz. Alle Rechte vorbehalten, insbesondere für den Fall der Patenterteilung oder GM-Entragung

use.....	19
ISAPWM_D_IS	
use.....	19, 28
L	
L_INH_IV_[CYL]	
use.....	26
LV_ACIN	
use.....	40
LV_AE	
def.....	24
use.....	22, 26, 30
LV_CT	
use.....	13, 14, 15, 17, 19, 24, 28
LV_DRI_ISAPWM	
use.....	24
LV_ES	
def.....	12
use.....	9, 31, 33, 37
LV_FL	
def.....	22
LV_IGA_AST	
def.....	36
LV_IGA_CH	
def.....	40
LV_IGK	
use.....	9, 12
LV_INF	
def.....	28
LV_IS	
def.....	14
use.....	13, 15, 17, 19, 24, 28, 30, 33, 36, 38, 40
LV_ISAPWM_IS_ACT	
use.....	36
LV_LSCL_1	
use.....	40
LV_LSCL_2	
use.....	40
LV_MAF_ERR	
use.....	40
LV_N_GRD_INF	
def.....	28
LV_N_SP_ADD_CH	
def.....	40
LV_PL	
def.....	15
use.....	13, 14, 17, 19, 22, 24, 30, 33, 36, 38
LV_PU	
def.....	17
use.....	14, 15, 19, 28, 30
LV_PU_PUC_TRA_FAST	
def.....	15
use.....	17
LV_PUC	
def.....	19
use.....	17, 26, 28, 30
LV_PUR	

Editor: Müller O.	17-Dec-97	Engine operating states	HMC_V6
Version: a 153589 from 18.12.97		657765.49.04	
File: CHAP_5.DOC	650H0000		Page 6 / 43

Proprietary data, company confidential. All rights reserved.
 Contient des informations confidentielles. Tous droits réservés.
 Comunicado como segredo empresarial. Reservados todos os direitos.
 Confidado como secreto industrial. Nos reservamos todos los derechos.

Weitergabe sowie Vervielfältigung dieser Unterlage, Verwertung und Mitteilung ihres Inhalts nicht gestattet, soweit nicht ausdrücklich zugestanden. Zuwiderhandlungen verpflichten zu Schadensersatz. Alle Rechte vorbehalten, insbesondere für den Fall der Patenterteilung oder GM-Entragung.

def.....	26
use.....	24
LV_REAC	
def.....	30
LV_REST	
def.....	33
LV_RLY_ACCOUT	
use.....	17, 19
LV_RLY_ACCOUT_CTRL	
use.....	24
LV_RLY_SAP	
use.....	38
LV_RWUP	
def.....	38
LV_SAV	
use.....	38
LV_ST	
def.....	13
use.....	11, 12, 14, 15, 31, 33, 36, 37, 40
LV_ST_ES	
def.....	31
use.....	33
LV_TI_AST	
def.....	36
LV_TI_CH	
def.....	40
LV_TPS_ERR	
use.....	24, 26
LV_TPS_FL	
use.....	22, 26, 40
LV_TPS_PLAUS_ERR	
use.....	24, 26
LV_VS_MAX	
use.....	24, 26
LV_WUP	
def.....	37
M	
MAF_MMV	
use.....	15
MAF_MMV_DIF	
use.....	15
N	
N	
use.....	11, 12, 14, 15, 17, 19
N_32	
use.....	11, 13, 14, 15, 17, 19, 22, 24, 26, 28, 31
N_DIF	
use.....	28, 36
N_GRD	
use.....	17, 19, 28
N_SP_IS	
use.....	40
N_SP_IS_MAX	
use.....	14, 15, 17, 19
NC_N_MIN	

Editor: Müller O.	17-Dec-97	Engine operating states	HMC_V6
Version: a 153589 from 18.12.97		657765.49.04	
File: CHAP_5.DOC	650H0000		Page 7 / 43

Proprietary data, company confidential. All rights reserved.
 Contient a titre de secret d'entreprise. Tous droits réservés.
 Comunicado como segredo empresarial. Reservados todos os direitos.
 Confidado como secreto industrial. Nos reservamos todos los derechos.

Weitergabe sowie Vervielfältigung dieser Unterlage, Verwertung und Mitteilung ihres Inhalts nicht gestattet, soweit nicht ausdrücklich zugestanden. Zuwiderhandlungen verpflichten zu Schadensersatz. Alle Rechte vorbehalten, insbesondere für den Fall der Patenterteilung oder GM-Eintragung

use.....	11, 12, 31
P	
PWL_DLY_CTR	
def.....	9
T	
TAR_GC	
use.....	24
TCO	
use.....	13, 15, 17, 19, 22, 24, 26, 33
TCO_REST	
use.....	33
TCO_ST	
use.....	40
TI_AE	
use.....	24
TI_CAST	
use.....	36
TI_PUR	
use.....	26
TI_WUP	
use.....	37
TPS	
use.....	22, 24, 26
TPS_GRD	
use.....	15, 24, 26
V	
VS	
use.....	22, 40

Editor: Müller O.	17-Dec-97	Engine operating states	HMC_V6
Version: a 153589 from 18.12.97		657765.49.04	
File: CHAP_5.DOC	650H0000		Page 8 / 43

Proprietary data, company confidential. All rights reserved. Contine a titre de secret d'entreprise. Tous droits réservés. Comunicado como segredo empresarial. Reservados todos os direitos. Confidado como secreto industrial. Nos reservamos todos los derechos.

Weitergabe sowie Vervielfältigung dieser Unterlage, Verwertung und Mitteilung ihres Inhalts nicht gestattet, soweit nicht ausdrücklich zugestanden. Zuwiderhandlungen verpflichten zu Schadenersatz. Alle Rechte vorbehalten, insbesondere für den Fall der Patenterteilung oder GM-Entragung.

1.1 General

A distinction is made on principle between the basic operating states and the auxiliary functions.

The basic operating states (e.g. **LV_ES**, **LV_ST**, **LV_IS**, **LV_PL**, **LV_PU** & **LV_PUC**) are independent basic functions which can only occur alternatively. Contrary to this, auxiliary functions can be simultaneously active and they always are superimposed on a basic operating state.

1.1.1 Engine operating state detection

General information:

If the detection of an engine operating state influences several output signals, this engine operating state is described in the chapter "Basic Operating States".

The engine operating state transitions are dependent on **throttle position** and **engine speed**.

The driver must be able to switch - off the engine by the ignition key in any operating state. To implement this, the battery voltage is measured.

For more explanations, refer to "Acquisition of ignition key battery voltage" in the major chapter "Inputs".

1.1.2 Power Latch

Output data:

Name	Mode	Hex. limits	Phys. limits	Resol.	Unit
PWL_DLY_CTR	V	0...FFH	0...255	1	-
Display lock of power latch resources by several functions					

Input data:

LV_IGK	LV_ES		
--------	-------	--	--

General information:

Ignition key on activates the power supply. The controller then starts initialization. During initialization the main relay is switched on. All actuators are supplied by the main relay with battery voltage, except ignition coils which are supplied from ignition key.

The power latch function is activated after ignition key off recognition and engine stopped. The power latch function holds the main relay active (and therefore the power supply) for a certain time. In this time for example learned values and detected failures can be stored to the flash. After expiration of the delay time main relay and power supply are switched off by the controller.

Furthermore certain functionalities can request continuation of post operating phase by increment of PWL_DLY_CTR. If they need no more power latch resources, they can stop their request by decrementation of PWL_DLY_CTR.

Editor: Müller O.	17-Dec-97	Engine operating states	HMC_V6
Version: a 153589 from 18.12.97		657765.49.04	
File: CHAP_5.DOC	650H0000	Sourcefile:07500101.00E	Page 9 / 43

The detection of power latch is done every 10 ms.

Application conditions:

Activation:

During initialization, main relay is switched to on.

Deactivation:

If the conditions (LV_IGK = 0) AND (LV_ES = 1) are fulfilled for an uninterrupted time C_T_MAX_ECU and PWL_DLY_CTR = 0, main relay and power supply are switched to off. After expiration of C_T_MAX_ECU a timer C_T_MAX_DLY_ECU will be initialized if PWL_DLY_CTR ≠ 0 and main relay is switched off latest after expiration of C_T_MAX_DLY_ECU.

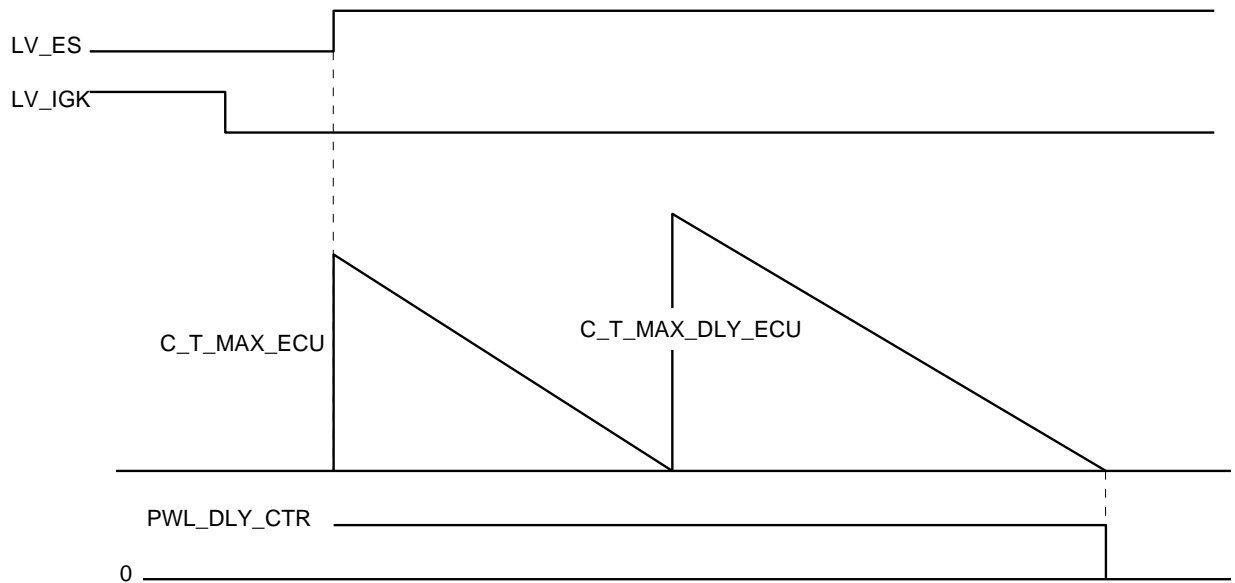

Calibration data:

Name	Dim	Hex. limits	Phys. limits	Resol.	Unit
C_T_MAX_ECU	1	0...FFFFH	0...65535	1	s
Duration of the normal power latch					
C_T_MAX_DLY_ECU	1	0...FFFFH	0...65535	1	s
Maximum on-time of ECU after ignition key off.					

Editor: Müller O.	17-Dec-97	Engine operating states	HMC_V6
Version: a 153589 from 18.12.97		657765.49.04	
File: CHAP_5.DOC	650H0000	Sourcefile:07500101.00E	Page 10 / 43

Proprietary data, company confidential. All rights reserved.
 Contient des données confidentielles. Tous droits réservés.
 Comunicado como secreto empresarial. Reservados todos los derechos.
 Confidado como secreto industrial. Nos reservamos todos los derechos.

Weitergabe sowie Vervielfältigung dieser Unterlage, Verwertung und Mitteilung ihres Inhalts nicht gestattet, soweit nicht ausdrücklich zugestanden. Zuwiderhandlungen verpflichten zu Schadensersatz. Alle Rechte vorbehalten, insbesondere für den Fall der Patenterteilung oder GM-Entragung.

Proprietary data, company confidential. All rights reserved. Contine a titre de secret d'entreprise. Tous droits réservés. Comunicado como segredo empresarial. Reservados todos os direitos. Confidado como secreto industrial. Nos reservamos todos los derechos.

Weitergabe sowie Vervielfältigung dieser Unterlage, Wertung und Mitteilung ihres Inhalts nicht gestattet, soweit nicht ausdrücklich zugestanden. Zuwiderhandlungen verpflichten zu Schadensersatz. Alle Rechte vorbehalten, insbesondere für den Fall der Patenterteilung oder GM-Enttragung

1.1.2.1 Function initialization

After initialization of the operating system and self - diagnosis of the control unit, the engine functions are assigned to their initial values.

The first measured values are diagnosed and backup values are made available as appropriate.

1.1.2.2 Reset with the system running

Input data:

N	NC_N_MIN	N_32	IP_N_MAX_TOL_ST__TCO
LV_ST			

FUNCTION DESCRIPTION:

General information:

If a reset occurs for $N \geq NC_N_MIN$, initialization is performed as for an under-voltage reset.

In the case of an engine speed $N_32 \geq IP_N_MAX_TOL_ST_TCO$ the engine operating state start (LV_ST) is not executed.

Instead, the system immediately branches to the current engine operating state.

Editor: Müller O.	17-Dec-97	Engine operating states	HMC_V6
Version: a 153589 from 18.12.97		657765.49.04	
File: CHAP_5.DOC	650H0000	Sourcefile:07500101.00E	Page 11 / 43

1.1.3 Engine operating state “ Engine Stopped ” (LV_ES)

Output data:

Name	Mode	Hex. limits	Phys. limits	Resol.	Unit
LV_ES	V	0...01H	0...1	1	-
Engine operating state " Engine Stopped " - Engine Operating State = ES.					

Input data:

LV_IGK	LV_ST	N	NC_N_MIN
--------	-------	---	----------

FUNCTION DESCRIPTION:

General information:

The engine operating state engine stopped (LV_ES) is characterized by ignition key **on** (LV_IGK = 1 (Active)) and $N < NC_N_MIN$.

In this engine operating state, the functions are assigned to initialization values. The entire scope of diagnosis and actuator control is accessible.

Application conditions:

Deactivation:

Exit to LV_ST : Start

During the synchronisation phase, the tooth duration is taken into account to calculate the engine speed.

- if** $N \geq NC_N_MIN$ is detected in the operating state engine stopped (LV_ES)
- then** the fuel pump is switched on
(refer to chapter : “ Relays control “ in major chapter “ Auxiliary Functions “)
- and** the first injection is performed
(refer to chapter : “ Fuel injection output “ in major chapter “ Outputs “)

Proprietary data, company confidential. All rights reserved. Contient des informations confidentielles de la société. Tous droits réservés. Comunicado como segredo empresarial. Reservados todos os direitos. Confidado como secreto industrial. Nos reservamos todos los derechos.

Weitergabe sowie Vervielfältigung dieser Unterlage, Verwertung und Mitteilung ihres Inhalts ist gestattet, soweit nicht ausdrücklich zugestanden. Zuwiderhandlungen verpflichten zu Schadensersatz. Alle Rechte vorbehalten, insbesondere für den Fall der Patenterteilung oder GM-Entragung.

Editor: Müller O.	17-Dec-97	Engine operating states	HMC_V6
Version: a 153589 from 18.12.97		657765.49.04	
File: CHAP_5.DOC	650H0000	Sourcefile:07500101.00E	Page 12 / 43

1.2 Basic Operating States : LV_ST, LV_IS, LV_PL, LV_PU, LV_PUC

1.2.1 Engine operating state : “ Start ” (LV_ST)

Output data:

Name	Mode	Hex. limits	Phys. limits	Resol.	Unit
LV_ST	V	0...01H	0...1	1	-
Engine operating state " Start " - Engine Operating State = ST.					
CYCNR_ES_ST	-	0...FFFFH	0...65535	1	-
Cycle-counter started at transition from LV_ES to LV_ST.					

Input data:

LV_CT	N_32	LV_IS	LV_PL
TCO			

FUNCTION DESCRIPTION:

General information:

The engine operating state " Start " (LV_ST) is detected from all engine operating states via means of engine speed.

At transition from LV_ES to LV_ST the cycle-counter CYCNR_ES_ST is started; it will be incremented each segment and reset at exit to LV_IS or LV_PL (see also chapter „Start break-off detection“).

Application conditions:

Deactivation:

- 1) **Exit to LV_IS:** Idle Speed
 - a) $N_{32} \geq IP_N_MAX_TOL_ST_TCO$
 - b) and $LV_CT = 1$
- 2) **Exit to LV_PL :** Part Load
 - a) $N_{32} \geq IP_N_MAX_TOL_ST_TCO$
 - b) and $LV_CT = 0$

Calibration data:

Name	Dim	Hex. limits	Phys. limits	Resol.	Unit
IP_N_MAX_TOL_ST__TCO	9	0...FFH	0...8160	32	rpm
High engine speed threshold between LV_ST and LV_IS.					

Editor: Müller O.	17-Dec-97	Engine operating states	HMC_V6
Version: a 153589 from 18.12.97		657765.49.04	
File: CHAP_5.DOC	650H0000	Sourcefile:07500201.00G	Page 13 / 43

Proprietary data, company confidential. All rights reserved. Contient des données confidentielles. Tous droits réservés. Comunicado como secreto empresarial. Reservados todos los derechos. Confidado como secreto industrial. Nos reservamos todos los derechos.

Weitergabe sowie Vervielfältigung dieser Unterlage, Verwertung und Mitteilung ihres Inhalts ist gestattet, soweit nicht ausdrücklich zugestanden. Zuwiderhandlungen verpflichten zu Schadensersatz. Alle Rechte vorbehalten, insbesondere für den Fall der Patenterteilung oder GM-Enttragung.

1.2.2 Engine operating state : “ Idle Speed ” (LV_IS)

Output data:

Name	Mode	Hex. limits	Phys. limits	Resol.	Unit
LV_IS	V	0...01H	0...1	1	-
Engine operating state " Idle Speed " - Engine Operating State = IS.					

Input data:

LV_CT	N_SP_IS_MAX	N_32	N
LV_ST	LV_PL	LV_PU	

FUNCTION DESCRIPTION:

Application conditions:

Deactivation:

- 1) **Exit to LV_ST** : Start
 - a) $N_{32} < C_{N_MAX_BOL_ST}$
- 2) **Exit to LV_PL** : Part Load
 - a) $N_{32} \geq C_{N_MAX_BOL_ST}$
 - b) and $LV_CT = 0$
- 3) **Exit to LV_PU** : Trailing Throttle
 - a) $N \geq N_{SP_IS_MAX}$
 - b) and $LV_CT = 1$
 - c) and $N_{32} \geq C_{N_MAX_BOL_ST}$

Calibration data:

Name	Dim	Hex. limits	Phys. limits	Resol.	Unit
C_N_MAX_BOL_ST	1	0...FFH	0...8160	32	rpm
Engine speed threshold to detect LV_ES from LV_PL or LV_FL or LV_IS.					

Proprietary data, company confidential. All rights reserved. Contine a titre de secret d'entreprise. Tous droits réservés. Comunicado como segredo empresarial. Reservados todos os direitos. Confidado como secreto industrial. Nos reservamos todos los derechos.

Weitergabe sowie Vervielfältigung dieser Unterlage, Verwertung und Mitteilung ihres Inhalts nicht gestattet, soweit nicht ausdrücklich zugestanden. Zuwiderhandlungen verpflichten zu Schadensersatz. Alle Rechte vorbehalten, insbesondere für den Fall der Patenterteilung oder GM-Enttragung.

Editor: Müller O.	17-Dec-97	Engine operating states	HMC_V6
Version: a 153589 from 18.12.97		657765.49.04	
File: CHAP_5.DOC	650H0000	Sourcefile:07500201.00G	Page 14 / 43

1.2.3 Engine operating state : “ Part Load ” (LV_PL)

Output data:

Name	Mode	Hex. limits	Phys. limits	Resol.	Unit
LV_PL	V	0...01H	0...1	1	-
Engine operating state " Part Load " - Engine Operating State = PL.					
LV_PU_PUC_TRA_FAST	V	0...01H	0...1	1	-
Boolean for fast deceleration status - (Passive / Active).					

Input data:

N	N_32	N_SP_IS_MAX	TCO
LV_CT	LV_ST	LV_IS	LV_PU
C_N_MAX_BOL_ST	TPS_GRD	MAF_MMV_DIF	MAF_MMV

FUNCTION DESCRIPTION:

Application conditions:

Deactivation:

1) Exit to LV_ST : Start

a) $N_{32} < C_{N_MAX_BOL_ST}$

2) Exit to LV_IS : Idle Speed

a) $N_{32} \geq C_{N_MAX_BOL_ST}$

b) and $N < N_{SP_IS_MAX}$

c) and $LV_CT = 1$

3) Exit to LV_PU : Trailing Throttle

a) $N \geq N_{SP_IS_MAX}$

b) and $LV_CT = 1$

c) and $N_{32} \geq C_{N_MAX_BOL_ST}$

Fast Deceleration Detection : LV_PU_PUC_TRA_FAST

if $(|TPS_GRD| > C_{TPS_GRD_MIN_PU} \text{ and } TPS_GRD < 0)$

and $TCO > C_{TCO_MIN_PU}$

and $MAF_MMV_DIF > C_{MAF_MMV_DIF_MIN_PU}$

and $msb(MAF_MMV) > IP_MAF_MMV_MIN_PU_N_{32}$

then

if $(N_{32} \geq C_{N_MIN_LGRD_PU} \text{ or } N_GRD > C_{N_GRD_MIN_PU})$

then $LV_PU_PUC_TRA_FAST = 1$

else $LV_PU_PUC_TRA_FAST = 0$

Editor: Müller O.	17-Dec-97	Engine operating states	HMC_V6
Version: a 153589 from 18.12.97		657765.49.04	
File: CHAP_5.DOC	650H0000	Sourcefile:07500201.00G	Page 15 / 43

Calibration data:

Name	Dim	Hex. limits	Phys. limits	Resol.	Unit
IP_MAF_MMV_MIN_PU__N_32	6	0...FFH	0...1389	5,45	mg/TDC
MAF_MMV threshold to detect fast deceleration.					
C_TPS_GRD_MIN_PU	1	0...FFH	0...2988	11,72	°TPS/sec
TPS_GRD threshold to detect fast deceleration.					
C_TCO_MIN_PU	1	0...FEH	-48...142,5	0,75	°C
Coolant temperature threshold to detect fast deceleration.					
C_MAF_MMV_DIF_MIN_PU	1	0...FFH	0...1389	5,45	mg/TDC
MAF_MMV_DIF threshold to detect fast deceleration.					
C_N_MIN_LGRD_PU	1	0...FFH	0...8160	32	rpm
Engine speed threshold to detect fast deceleration.					
C_N_GRD_MIN_PU	1	80...7FH	-4096...4064	32	rpm/sec
Engine speed gradient threshold to detect fast deceleration.					

Proprietary data, company confidential. All rights reserved.
 Contine a titre de secret d'entreprise. Tous droits réservés.
 Comunicado como segredo empresarial. Reservados todos os direitos.
 Confidado como secreto industrial. Nos reservamos todos los derechos.

Weitergabe sowie Vervielfältigung dieser Unterlage, Verwertung und Mitteilung ihres Inhalts nicht gestattet, soweit nicht ausdrücklich zugestanden. Zuwiderhandlungen verpflichten zu Schadensersatz. Alle Rechte vorbehalten, insbesondere für den Fall der Patenterteilung oder GM-Eintragung

Editor: Müller O.	17-Dec-97	Engine operating states	HMC_V6
Version: a 153589 from 18.12.97		657765.49.04	
File: CHAP_5.DOC	650H0000	Sourcefile:07500201.00G	Page 16 / 43

1.2.4 Engine operating state : “ Trailing Throttle ” (LV_PU)

Output data:

Name	Mode	Hex. limits	Phys. limits	Resol.	Unit
LV_PU	V	0...01H	0...1	1	-
Engine operating state " Trailing Throttle " - Engine Operating State = PU					

Input data:

LV_CT	LV_PU_PUC_TRA_FAST	LV_PL	LV_IS
LV_PUC	LV_RLY_ACCOUT	N	N_32
N_SP_IS_MAX	N_GRD	IGA_PU_PUC	TCO

FUNCTION DESCRIPTION:

Application conditions:

Deactivation:

1) **Exit to LV_PL** : Part Load

a) LV_CT = 0

2) **Exit to LV_IS** : Idle Speed

a) LV_CT = 1

b) **and** N < N_SP_IS_MAX

3) **Exit to LV_PUC** : Trailing Throttle Fuel Cut Off

a) LV_CT = 1

b) **and**

b1) $N_{32} \geq IP_N_MIN_PUC_TCO_GR_MT + \text{Hysteresis}$

b2) **or** $N_{32} \geq IP_N_ACCIN_MIN_PUC_TCO_GR_MT + \text{Hyst.}$

(LV_RLY_ACCOUT = 1)

c) **and** ISAPWM_D_IS is inactive

d) **and**

d1) $N_{32} \geq C_N_MAX_INF$

d2) **or** ($N_{32} < C_N_MAX_INF$ **and** $N_GRD \geq C_N_GRD_MIN$)

Remark :

The conditions to leave immediately or to stay temporarily in trailing throttle (LV_PU) to trailing throttle fuel cut-off (LV_PUC) are depending on the type of deceleration (LV_PU_PUC_TRA_FAST) and engine speed threshold (N_32).

(refer to the chapter “ Trailing throttle ignition angle correction (IGA_PU_PUC) “ in the major chapter “ Ignition “)

Editor: Müller O.	17-Dec-97	Engine operating states	HMC_V6
Version: a 153589 from 18.12.97		657765.49.04	
File: CHAP_5.DOC	650H0000	Sourcefile:07500201.00G	Page 17 / 43

Proprietary data, company confidential. All rights reserved. Contine a titre de secret d'entreprise. Tous droits réservés. Comunicado como segredo empresarial. Reservados todos os direitos. Confidado como secreto industrial. Nos reservamos todos los derechos.

Weitergabe sowie Vervielfältigung dieser Unterlage, Wertung und Mitteilung ihres Inhalts nicht gestattet, soweit nicht ausdrücklich zugestanden. Zuwiderhandlungen verpflichten zu Schadenersatz. Alle Rechte vorbehalten, insbesondere für den Fall der Patenterteilung oder GM-Enttragung.

Calibration data:

Name	Dim	Hex. limits	Phys. limits	Resol.	Unit
IP_N_MIN_PUC__TCO__GR_MT	6*6	0...FFH	0...8160	32	rpm
LV_PUC engine speed threshold.					
IP_N_ACCIN_MIN_PUC__TCO__GR_MT	6*6	0...FFH	0...8160	32	rpm
LV_PUC engine speed threshold with air conditioning compressor active.					
C_N_MAX_INF	1	0...FFH	0...8160	32	rpm
Engine speed threshold for intercept function.					
C_N_GRD_MIN	1	80...FFH	-4096...0	32	rpm/sec
Negative engine speed gradient threshold when ISAPWM_D_IS is inactive.					

Proprietary data, company confidential. All rights reserved. Contine a titre de secret d'entreprise. Tous droits réservés. Comunicado como segredo empresarial. Reservados todos os direitos. Confidado como secreto industrial. Nos reservamos todos los derechos.

Weitergabe sowie Vervielfältigung dieser Unterlage, Wertung und Mitteilung ihres Inhalts nicht gestattet, soweit nicht ausdrücklich zugestanden. Zuwiderhandlungen verpflichten zu Schadensersatz. Alle Rechte vorbehalten, insbesondere für den Fall der Patenterteilung oder GM-Eintragung.

Editor: Müller O.	17-Dec-97	Engine operating states	HMC_V6
Version: a 153589 from 18.12.97		657765.49.04	
File: CHAP_5.DOC	650H0000	Sourcefile:07500201.00G	Page 18 / 43

1.2.5 Engine operating state : “ Trailing Throttle Fuel Cut Off ” (LV_PUC)

Output data:

Name	Mode	Hex. limits	Phys. limits	Resol.	Unit
LV_PUC	V	0...01H	0..1	1	-
Engine operating state " Trailing Throttle Fuel Cut - Off " - Engine Operating State = PUC.					

Input data:

LV_CT	C_N_GRD_MIN	N	N_32
N_SP_IS_MAX	N_GRD	TCO	ISAPWM_D_IS
LV_PL	LV_IS	LV_PU	LV_RLY_ACCOUT
IP_N_MIN_PUC__TCO__GR_MT	IP_N_ACCIN_MIN_PUC__TCO__GR_MT	C_N_MAX_INF	

FUNCTION DESCRIPTION:

General information:

The engine speed threshold for the detection of LV_PUC is derived from a characteristic as a function of coolant temperature IP_N_MIN_PUC__TCO__GR_MT. There is a special characteristic for the air condition compressor active IP_N_ACCIN_MIN_PUC__TCO__GR_MT.

Limp Home :

If a present failure is detected on the idle-charge actuator (refer to chapter „Diagnosis management“), the engine speed threshold for the detection of trailing throttle fuel cut-off (LV_PUC) is set to C_N_MIN_PUC_DIAG (limp-home value). This causes trailing throttle fuel cut-off to be shifted towards higher engine speed when the engine is at operating temperature.

Function " LV_PUC Hysteresis " :

When entering trailing throttle fuel cut-off (LV_PUC), the engine speed hysteresis is set to a larger value, i.e. C_N_HYS_MAX_PUC, and a cycle counter is loaded with an adjustable number, i.e. C_CYCNR_HYS_PUC. The cycle counter is decremented at intervals of a crank angle segment in any engine operating state except trailing throttle fuel cut-off (LV_PUC).

When the counter has been ran down, the engine speed hysteresis is reset to the value C_N_HYS_MIN_PUC. This measure is to prevent the injection system from being switched on and off continuously, which is undesirable.

If the coolant temperature is below the threshold C_TCO_MIN_PUC_ST when the engine is started, then the engine speed hysteresis for the detection of trailing throttle fuel cut off LV_PUC is increased to an adjustable value, i.e. C_N_HYS_PUC_ST, for an adjustable number of cycles C_CYCNR_HYS_PUC_ST. This results in faster catalyst heat-up during trailing throttle operation.

When the trailing throttle fuel cut-off (LV_PUC) is active, the individual cylinder restart fuel feed function can be started.

Editor: Müller O.	17-Dec-97	Engine operating states	HMC_V6
Version: a 153589 from 18.12.97		657765.49.04	
File: CHAP_5.DOC	650H0000	Sourcefile:07500201.00G	Page 19 / 43

Proprietary data, company confidential. All rights reserved. Contine a titre de secret d'entreprise. Tous droits réservés. Comunicado como segredo empresarial. Reservados todos os direitos. Confidado como secreto industrial. Nos reservamos todos los derechos.

Weitergabe sowie Vervielfältigung dieser Unterlage, Verwertung und Mitteilung ihres Inhalts nicht gestattet, soweit nicht ausdrücklich zugestanden. Zuwiderhandlungen verpflichten zu Schadensersatz. Alle Rechte vorbehalten, insbesondere für den Fall der Patenterteilung oder GM-Entragung.

Description:

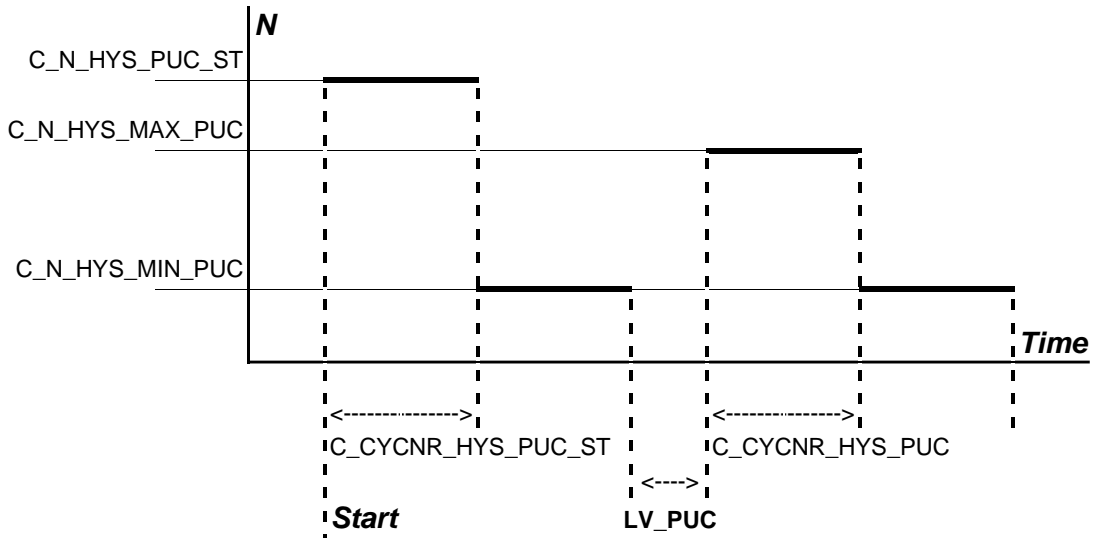

Application conditions:

Deactivation:

1) Exit to LV_IS : Idle Speed

a) LV_CT = 1

b) and

b1)

b12) $N_{32} < IP_N_MIN_PUC_TCO_GR_MT$

b13) **or** $N_{32} < IP_N_ACCIN_MIN_PUC_TCO_GR_MT$

(LV_RLY_ACCOUT = 1)

b2) **or**

b21) $N_{32} < C_N_MAX_INF$

b22) **and** $N_GRD < C_N_GRD_MIN$

b3) **or**

b31) $N_{32} < C_N_MAX_INF$

b32) **and** $N_GRD < C_N_GRD_MIN_D$

(ISAPWM_D_IS is active)

c) **and** $N < N_SP_IS_MAX$

Proprietary data, company confidential. All rights reserved. Contiene información confidencial. Todos los derechos reservados. Comunicado como secreto empresarial. Reservados todos los derechos. Confiado como secreto industrial. Nos reservamos todos los derechos.

Weitergabe sowie Vervielfältigung dieser Unterlage, Verwertung und Mitteilung ihres Inhalts ist gestattet, soweit nicht ausdrücklich zugestanden. Zuwiderhandlungen verpflichten zu Schadensersatz. Alle Rechte vorbehalten, insbesondere für den Fall der Patenterteilung oder GM-Entragung.

Editor: Müller O.	17-Dec-97	Engine operating states	HMC_V6
Version: a 153589 from 18.12.97		657765.49.04	
File: CHAP_5.DOC	650H0000	Sourcefile:07500201.00G	Page 20 / 43

Proprietary data, company confidential. All rights reserved.
 Contit a titre de secret d'entreprise. Tous droits réservés.
 Comunicado como segredo empresarial. Reservados todos os direitos.
 Confidado como secreto industrial. Nos reservamos todos los derechos.

Weitergabe sowie Vervielfältigung dieser Unterlage, Verwertung und Mitteilung ihres Inhalts nicht gestattet, soweit nicht ausdrücklich zugestanden. Zuwiderhandlungen verpflichten zu Schadensersatz. Alle Rechte vorbehalten, insbesondere für den Fall der Patenterteilung oder GM-Entragung.

2) Exit to LV_PU : Trailing Throttle

- a) LV_CT = 1
- b) and
 - b1)
 - b12) N_32 < IP_N_MIN_PUC__TCO__GR_MT
 - b13) or N_32 < IP_N_ACCIN_MIN_PUC__TCO__GR_MT
(LV_RLY_ACCOUT = 1)
 - b2) or
 - b21) N_32 < C_N_MAX_INF
 - b22) and N_GRD < C_N_GRD_MIN
 - b3) or
 - b31) N_32 < C_N_MAX_INF
 - b32) and N_GRD < C_N_GRD_MIN_D
(ISAPWM_D_IS is active)
- c) and N ≥ N_SP_IS_MAX

3) Exit to LV_PL: Part Load

- a) LV_CT = 0

Calibration data:

Name	Dim	Hex. limits	Phys. limits	Resol.	Unit
C_N_GRD_MIN_D	1	80...00H	- 4096...0	32	rpm/s.
Negative engine speed gradient threshold when ISAPWM_D_IS is active.					
C_N_MIN_PUC_DIAG	1	0...FFH	0...8160	32	rpm
Engine speed threshold for trailing throttle fuel cut off limp home.					
C_N_HYS_MAX_PUC	1	0...FFH	0...8160	32	rpm
Engine speed hysteresis set entering LV_PUC.					
C_N_HYS_MIN_PUC	1	0...FFH	0...8160	32	rpm
Engine speed hysteresis reset when C_CYCNR_HYS_PUC_xx achieved.					
C_N_HYS_PUC_ST	1	0...FFH	0...8160	32	rpm
Engine speed hysteresis set entering LV_PUC in cold condition.					
C_CYCNR_HYS_PUC	1	0...FFFFH	0...65535	x Segment	° CRK
Cycle counter to reset the LV_PUC engine speed hysteresis					
C_CYCNR_HYS_PUC_ST	1	0...FFFFH	0...65535	x Segment	° CRK
Cycle counter to reset the LV_PUC engine speed hysteresis in cold condition.					
C_TCO_MIN_PUC_ST	1	0...FEH	- 48...142,5	0,75	° C
Coolant temperature to select the LV_PUC engine speed hysteresis.					

Editor: Müller O.	17-Dec-97	Engine operating states	HMC_V6
Version: a 153589 from 18.12.97		657765.49.04	
File: CHAP_5.DOC	650H0000	Sourcefile:07500201.00G	Page 21 / 43

1.3 Basic functions : LV_FL, LV_AE, LV_PUR, LV_INF, LV_REAC

1.3.1 Full Load (LV_FL)

Output data:

Name	Mode	Hex. limits	Phys. limits	Resol.	Unit
LV_FL	V	0..01H	0..1	1	-
Basic function " Full Load " - LV_FL = FL					

Input data:

TPS	N_32	TCO	VS
LV_AE	LV_PL	LV_TPS_FL	C_TPS_HYS_FL
ID_TPS_FL__N_32			

FUNCTION DESCRIPTION:

General information:

The throttle position angle threshold required for detection of the full load state (LV_FL) is derived from an engine speed related table.

Another acceleration enrichment (LV_AE) cannot be triggered during full load (LV_FL); an existing acceleration enrichment (LV_AE) intervention continues, taking into account maximum injection time value selection.

Description:

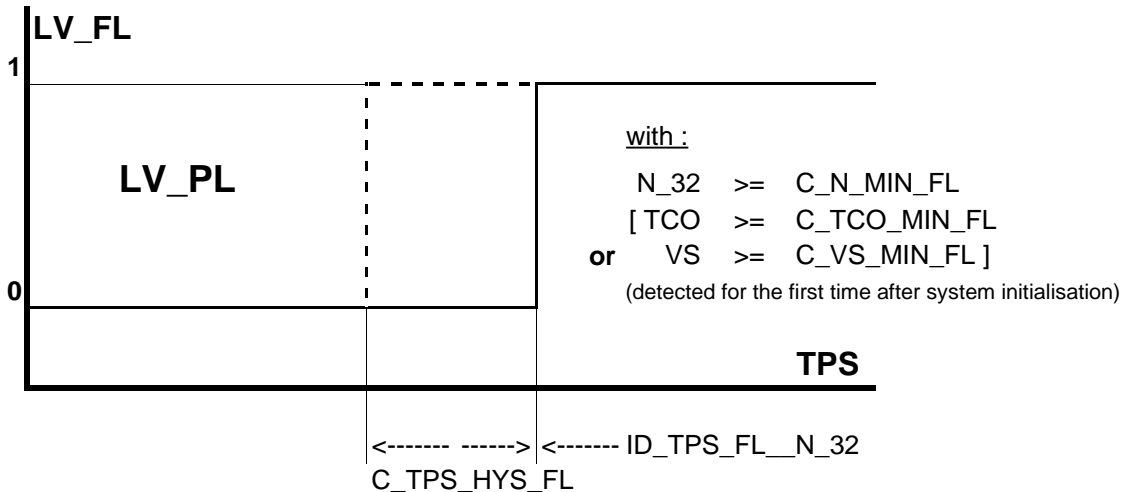

Editor: Müller O.	17-Dec-97	Engine operating states	HMC_V6
Version: a 153589 from 18.12.97		657765.49.04	
File: CHAP_5.DOC	650H0000	Sourcefile:07500301.00H	Page 22 / 43

Proprietary data, company confidential. All rights reserved. Contient des informations confidentielles. Tous droits réservés. Comunicado como segredo empresarial. Reservados todos os direitos. Confidado como secreto industrial. Nos reservamos todos los derechos.

Weitergabe sowie Vervielfältigung dieser Unterlage, Verwertung und Mitteilung ihres Inhalts ist gestattet, soweit nicht ausdrücklich zugestanden. Zuwiderhandlungen verpflichten zu Schadensersatz. Alle Rechte vorbehalten, insbesondere für den Fall der Patenterteilung oder GM-Entragung.

Application conditions:

Activation: LV_FL = FL

- a) LV_TPS_FL = **1** (Active)
- b) **and** N_32 ≥ C_N_MIN_FL
- c) **and**
 - c1) TCO ≥ C_TCO_MIN_FL
 - c2) **or** VS ≥ C_VS_MIN_FL
(detected for the first time after system initialisation)

Deactivation: LV_FL = -

- a) LV_TPS_FL = **0** (Passive)
- b) **or** N_32 < C_N_MIN_FL
- c) **or**
 - c1) TCO < C_TCO_MIN_FL
 - c2) **and** VS < C_VS_MIN_FL
(since system initialisation)

Calibration data:

Name	Dim	Hex. limits	Phys. limits	Resol.	Unit
C_N_MIN_FL	1	0...FFH	0...8160	32	rpm
Engine speed threshold for LV_FL detection.					
C_TCO_MIN_FL	1	0...FEH	-48...142,5	0,75	°C
Coolant temperature threshold for LV_FL detection.					
C_VS_MIN_FL	1	0...FFH	0...255	1	km / h
Vehicle speed threshold for LV_FL detection.					

Proprietary data, company confidential. All rights reserved.
 Contient des données confidentielles de l'entreprise. Tous droits réservés.
 Comunicado como secreto empresarial. Reservados todos los derechos.
 Confidado como secreto industrial. Nos reservamos todos los derechos.

Weitergabe sowie Vervielfältigung dieser Unterlage, Verbreitung und Mitteilung ihres Inhalts nicht gestattet, soweit nicht ausdrücklich zugestanden. Zuwiderhandlungen verpflichten zu Schadensersatz. Alle Rechte vorbehalten, insbesondere für den Fall der Patenterteilung oder GM-Eintragung.

Editor: Müller O.	17-Dec-97	Engine operating states	HMC_V6
Version: a 153589 from 18.12.97		657765.49.04	
File: CHAP_5.DOC	650H0000	Sourcefile:07500301.00H	Page 23 / 43

1.3.2 Acceleration Enrichment (LV_AE)

Output data:

Name	Mode	Hex. limits	Phys. limits	Resol.	Unit
LV_AE	V	0...01H	0...1	1	-
Basic function " Acceleration Enrichment " - LV_AE = AE.					

Input data:

LV_CT	LV_PL	LV_PUR	N_32
TCO	TPS	TPS_GRD	LV_DRI_ISAPWM
TI_AE	LV_VS_MAX	LV_IS	LV_TPS_ERR
LV_TPS_PLAUS_ERR	LV_RLY_ACCOUT_CTRL	TAR_GC	

FUNCTION DESCRIPTION:

General information:

The acceleration enrichment function (LV_AE) is activated if:

- Throttle position gradient (TPS_GRD), determined in part load (LV_PL), exceeds a threshold.
- Gear ratio with A/T (TAR_GC) is increasing or A/C switched ON in Idle and coolant temperature is below a threshold

Application conditions:

Activation: **LV_AE= AE**

- a) LV_CT = 0
- a1) **and** TPS_GRD ≥ ID_TPS_GRD_BOL_AE(_AT)_N_32_TPS
+ ID_TPS_GRD_ADD_AE(_AT)_TCO
- a2) **and** TPS_GRD ≥ 0
- b) **or**
- b1) TCO < C_TCO_DRI_MIN_AE
- b2) **and**
- c1) LV_IS = 1
- c2) **and** Transition A/C Off -> On
(LV_RLY_ACCOUT_CTRL = 0 -> 1)
- or**
- d1) TAR_GC_n > TAR_GC_{n-1}
- e) **and** No Cylinder shut-off
- f) **and** No disabling conditions for fuel enrichment due to an auxiliary function
(LV_VS_MAX = 0)

Editor: Müller O.	17-Dec-97	Engine operating states	HMC_V6
Version: a 153589 from 18.12.97		657765.49.04	
File: CHAP_5.DOC	650H0000	Sourcefile:07500301.00H	Page 24 / 43

Remark : Limp home function

In case of a failure currently detected at the throttle position sensor (LV_TPS_ERR = 1 or LV_TPS_PLAUS_ERR = 1) a substitute value is available. In this case, the release threshold for the instationary function LV_AE / LV_PUR (TPS_GRD condition) is modified to be less sensitive by addition of C_TPS_GRD_ADD_DIAG. These conditions have only to be met to trigger acceleration enrichment (LV_AE).

Deactivation: LV_AE = -

After being activated, acceleration enrichment function (LV_AE) continues until it is automatically deactivated (TI_AE = 0), or until it is disabled by one of the following events :

- a) LV_CT = 1
 - a1) **and** Engine operating state idle not active LV_IS = 0
- b) **or** Transition Drive (LV_DRI_ISAPWM = 1) -> Park/Neutral (LV_DRI_ISAPWM = 0)
 - b1) **and** Engine operating state idle not active LV_IS = 0
- c) **or** Transition A/C requested (LV_ACCIN = 1) -> A/C off (LV_ACCIN = 0)
 - c1) **and** Engine operating state idle not active LV_IS = 0
- d) **or** disabling conditions for fuel enrichment due to an auxiliary function
(LV_VS_MAX = 1 (Active))
- e) **or** cylinder shut-off active.

Calibration data:

Name	Dim	Hex. limits	Phys. limits	Resol.	Unit
ID_TPS_GRD_BOL_AE(AT)_N_32_TPS	6 x 4	0...FFH	0...2988	11,71	° TPS / sec
Throttle position gradient threshold versus N_32 and TPS for LV_AE detection.					
ID_TPS_GRD_ADD_AE(AT)_TCO	6	80...7FH	- 1500...1488	11,71	° TPS / sec
Throttle position gradient threshold versus TCO for LV_AE detection.					
C_TPS_GRD_ADD_DIAG	1	0...FFH	0...2988	11,71	° TPS / sec
Throttle position gradient threshold for LV_AE limp home detection.					
C_TCO_DRI_MIN_AE	1	0...FEH	-48...142,5	0,75	° C
Maximum coolant temperature to activate AE after a transition Neutral -> Drive					

Proprietary data, company confidential. All rights reserved. Contine a titre de secret d'entreprise. Tous droits réservés. Comunicado como segredo empresarial. Reservados todos os direitos. Confidado como secreto industrial. Nos reservamos todos los derechos.

Weitergabe sowie Vervielfältigung dieser Unterlage, Wertung und Mitteilung ihres Inhalts nicht gestattet, soweit nicht ausdrücklich zugestanden. Zuwiderhandlungen verpflichten zu Schadensersatz. Alle Rechte vorbehalten, insbesondere für den Fall der Patenterteilung oder GM-Entragung.

Editor: Müller O.	17-Dec-97	Engine operating states	HMC_V6
Version: a 153589 from 18.12.97		657765.49.04	
File: CHAP_5.DOC	650H0000	Sourcefile:07500301.00H	Page 25 / 43

1.3.3 Trailing Throttle Fuel Reduction (LV_PUR)

Output data:

Name	Mode	Hex. limits	Phys. limits	Resol.	Unit
LV_PUR	V	0...01H	0...1	1	-
Basic function " Trailing Throttle Fuel Reduction " - LV_PUR = PUR.					

Input data:

LV_TPS_FL	TPS	TPS_GRD	N_32
LV_AE	LV_PUC	TCO	LV_TPS_ERR
C_TPS_GRD_ADD_DIAG	LV_VS_MAX	TI_PUR	L_INH_IV_[CYL]
LV_TPS_PLAUS_ERR			

FUNCTION DESCRIPTION:

General information:

The trailing throttle fuel reduction function (LV_PUR) is triggered when the negative throttle position gradient TPS_GRD reaches or falls below a threshold.

The states LV_AE and LV_PUR can be simultaneously active.

The dashpot function is reset independently of LV_PUR.

Application conditions:

Activation: LV_PUR = PUR

a) LV_TPS_FL = 0

b) and

$$b1) \quad |TPS_GRD| \geq ID_TPS_GRD_BOL_PUR(AT)_N_32_TPS + ID_TPS_GRD_ADD_PUR(AT)_TCO$$

b2) and TPS_GRD < 0

c) and No disabling conditions for fuel enrichment due to an auxiliary function.

(LV_VS_MAX = 0 (Passive))

Remark : Limp home function

In case of a present failure detected on the throttle position sensor (LV_TPS_ERR = 1 or LV_TPS_PLAUS_ERR = 1), a substitute value is available. In this case, the release threshold for the instationary function LV_AE / LV_PUR (TPS_GRD condition) is modified to be less sensitive by addition of C_TPS_GRD_ADD_DIAG.

Proprietary data, company confidential. All rights reserved. Contine a titre de secret d'entreprise. Tous droits réservés. Comunicado como segredo empresarial. Reservados todos os direitos. Confidado como secreto industrial. Nos reservamos todos los derechos.

Weitergabe sowie Vervielfältigung dieser Unterlage, Verwertung und Mitteilung ihres Inhalts nicht gestattet, soweit nicht ausdrücklich zugestanden. Zuwiderhandlungen verpflichten zu Schadensersatz. Alle Rechte vorbehalten, insbesondere für den Fall der Patenterteilung oder GM-Entragung

Editor: Müller O.	17-Dec-97	Engine operating states	HMC_V6
Version: a 153589 from 18.12.97		657765.49.04	
File: CHAP_5.DOC	650H0000	Sourcefile:07500301.00H	Page 26 / 43

Deactivation: LV_PUR = -

After being activated, the trailing throttle fuel reduction function (LV_PUR) continues until it is automatically deactivated (TI_PUR = 0), or until it is disabled by one of the following events :

- a) LV_TPS_FL = 1
- b) **or** disabling conditions for fuel enrichment due to an auxiliary function
(LV_VS_MAX = 1 (Active))
- c) **or** the injection of one or more cylinders is inhibited (L_INH_IV_[CYL = 1)

Calibration data:

Name	Dim	Hex. limits	Phys. limits	Resol.	Unit
ID_TPS_GRD_BOL_PUR(_AT)__N_32__T PS	6 x 4	0...FFH	0...2988	11,71	° TPS / sec
Throttle position gradient threshold versus N_32 and TPS for LV_PUR detection.					
ID_TPS_GRD_ADD_PUR(_AT)__TCO	6	80...7FH	- 1500...1488	11,71	° TPS / sec
Throttle position gradient threshold versus TCO for LV_PUR detection.					

Proprietary data, company confidential. All rights reserved.
 Contit a titre de secret d'entreprise. Tous droits réservés.
 Comunicado como secreto empresarial. Reservados todos os direitos.
 Confidado como secreto industrial. Nos reservamos todos los derechos.

Weitergabe sowie Vervielfältigung dieser Unterlage, Verwertung und Mitteilung ihres Inhalts nicht gestattet, soweit nicht ausdrücklich zugestanden. Zuwiderhandlungen verpflichten zu Schadensersatz. Alle Rechte vorbehalten, insbesondere für den Fall der Patenterteilung oder GM-Entragung

Editor: Müller O.	17-Dec-97	Engine operating states	HMC_V6
Version: a 153589 from 18.12.97		657765.49.04	
File: CHAP_5.DOC	650H0000	Sourcefile:07500301.00H	Page 27 / 43

1.3.4 Intercept function (LV_INF)

Output data:

Name	Mode	Hex. limits	Phys. limits	Resol.	Unit
LV_INF	V	0..01H	0..1	1	-
Basic function " Intercept "- LV_INF = INF.					
LV_N_GRD_INF	V	0..01H	0..1	1	-
" Intercept " conditions for ignition intervention - (Passive / Active).					

Input data:

LV_PU	LV_PUC	LV_IS	N_GRD
C_N_GRD_MIN	C_N_GRD_MIN_D	C_N_MAX_INF	N_DIF
N_32	ISAPWM_D_IS	LV_CT	C_ISAPWM_LGRD_D

FUNCTION DESCRIPTION:

General information:

In the engine operating conditions trailing throttle (LV_PU), trailing throttle fuel cut-off (LV_PUC) or restart fuel feed function (LV_PUR) active in idle speed (LV_IS), the intercept function (LV_INF) can be enabled below an engine speed threshold C_N_MAX_INF.

The engine-speed gradient N_GRD is monitored for this purpose.

The engine operating state trailing throttle fuel cut-off (LV_PUC) is aborted when the intercept function (LV_INF) is triggered, and a transition to trailing throttle (LV_PU) or idle speed (LV_IS) takes place.

Application conditions:

Activation: LV_INF = INF

- a) **if** LV_CT = 1
- and** N_32 < C_N_MAX_INF
- and** N_GRD < C_N_GRD_MIN
- then** LV_N_GRD_INF = 1 (Active)
- and** an ignition intervention is initiated to counteract the high negative engine speed gradient.
- else** LV_N_GRD_INF = 0 (Passive)

Proprietary data, company confidential. All rights reserved. Contine a titre de secret d'entreprise. Tous droits réservés. Comunicado como segredo empresarial. Reservados todos os direitos. Confidado como secreto industrial. Nos reservamos todos los derechos.

Weitergabe sowie Vervielfältigung dieser Unterlage, Verbreitung und Mitteilung ihres Inhalts nicht gestattet, soweit nicht ausdrücklich zugestanden. Zuwiderhandlungen verpflichten zu Schadenersatz. Alle Rechte vorbehalten, insbesondere für den Fall der Patenterteilung oder GM-Entragung.

Editor: Müller O.	17-Dec-97	Engine operating states	HMC_V6
Version: a 153589 from 18.12.97		657765.49.04	
File: CHAP_5.DOC	650H0000	Sourcefile:07500301.00H	Page 28 / 43

Proprietary data, company confidential. All rights reserved. Contine a titre de secret d'entreprise. Tous droits réservés. Comunicado como secreto empresarial. Reservados todos os direitos. Confidado como secreto industrial. Nos reservamos todos los derechos.

Weitergabe sowie Vervielfältigung dieser Unterlage, Verwertung und Mitteilung ihres Inhalts nicht gestattet, soweit nicht ausdrücklich zugestanden. Zuwiderhandlungen verpflichten zu Schadensersatz. Alle Rechte vorbehalten, insbesondere für den Fall der Patenterteilung oder GM-Enttragung.

- b) **if** $LV_CT = 1$
- and** $N_DIF \leq 0$
- then**
- if** $N_32 < C_N_MAX_INF$
- and** $N_GRD < C_N_GRD_MIN_D$
- and** ISAPWM_D_IS inactive
- then** a "D - component " from idle speed regulation correction becomes effective (and a timer C_T_MIN_D_ISA is activated) in order to facilitate an engine intercept without drop below the nominal engine idle speed.

Deactivation: LV_INF = -

- a) After being activated, the intercept function (LV_INF) continues until it is automatically deactivated (with ignition intervention).
- b) **or** ($LV_CT = 0$ **or** $N_DIF > 0$)
 The "D - component" of idle speed regulation correction is controlled down to 0 using C_ISAPWM_LGRD_D (limitation gradient) and the timer C_T_MIN_D_ISA is reset.

Calibration data:

Name	Dim	Hex. limits	Phys. limits	Resol.	Unit
C_T_MIN_D_ISA	1	01...FFFFH	0,01...655,35	0,01	sec
Time delay to abort D - component idle-control device with LV_INF function.					

Editor:	Müller O.	17-Dec-97	Engine operating states	HMC_V6
Version:	a 153589 from 18.12.97		657765.49.04	
File:	CHAP_5.DOC	650H0000	Sourcefile:07500301.00H	Page 29 / 43

1.3.5 Re-start fuel feed function (LV_REAC)

Output data:

Name	Mode	Hex. limits	Phys. limits	Resol.	Unit
LV_REAC	V	0...01H	0:1	1	-
Basic function " Re-start fuel feed " - LV_REAC = REAC.					

Input data:

LV_PU	LV_PUC	LV_IS	LV_PL
LV_AE			

FUNCTION DESCRIPTION:

General information:

In order to obtain a soft engine torque built, the ignition angle is controlled from the trailing throttle fuel cut-off (LV_PUC) ignition angle to the new target ignition angle using a gradient limitation.

If *ignition intervention* for re-start fuel feed function is active, then LV_REAC = 1 (REAC).

Application conditions:

Activation: LV_REAC = 1 (REAC)

Re-start fuel feed at idle (LV_IS) or at trailing throttle (LV_PU) or at part load (LV_PL) (with or without acceleration enrichment (LV_AE)) is enabled while the trailing throttle fuel cut-off (LV_PUC) is active, when the corresponding engine operating state is performed.

Deactivation: LV_REAC = 0 (-)

After being activated, the re-start fuel feed at idle (LV_IS) or at trailing throttle (LV_PU) or at part load (LV_PL) continues until it is automatically de-activated (when ignition intervention is over).

Proprietary data, company confidential. All rights reserved. Contient a titre de secret d'entreprise. Tous droits réservés. Comunicado como segredo empresarial. Reservados todos os direitos. Confidado como secreto industrial. Nos reservamos todos los derechos.

Weitergabe sowie Vervielfältigung dieser Unterlage, Verwertung und Mitteilung ihres Inhalts nicht gestattet, soweit nicht ausdrücklich zugestanden. Zuwiderhandlungen verpflichten zu Schadenersatz. Alle Rechte vorbehalten, insbesondere für den Fall der Patenterteilung oder GM-Entragung.

Editor: Müller O.	17-Dec-97	Engine operating states	HMC_V6
Version: a 153589 from 18.12.97		657765.49.04	
File: CHAP_5.DOC	650H0000	Sourcefile:07500301.00H	Page 30 / 43

1.4 Auxiliary functions

1.4.1 Start break-off detection (LV_ST_ES)

Output data:

Name	Mode	Hex. limits	Phys. limits	Resol.	Unit
LV_ST_ES	V	0..01H	0..1	1	-
Detection of engine start break-off- (Passive / Active).					

Input data:

LV_ST	LV_ES	CYCNR_ES_ST	N_32
NC_N_MIN	IP_N_MAX_TOL_ST_TCO	C_T_MAX_ECU	

FUNCTION DESCRIPTION:

General information:

For engine stall during start phase, i.e. transition from LV_ST to LV_ES before N_32 reaching IP_N_MAX_TOL_ST_TCO, the flag LV_ST_ES is set to 1. At the same time the counter CYCNR_ES_ST will be freezed to its actual value.

Additionally a timer is started at the transition from LV_ST to LV_ES. If the timer ellapses before a new start takes place ($T > C_T_MIN_ECU_REST$), LV_ST_ES is reset (see picture on this page) and CYCNR_ES_ST is set to zero.

Whereas LV_ST_ES remains set to 1 until the engine operation state start is exited to part load or idle if a new start takes place before the timer has ellapsed ($T < C_T_MIN_ECU_REST$) In this case the counter CYCNR_ES_ST starts with the frozen value at the new start (see picture on next page).

Description:

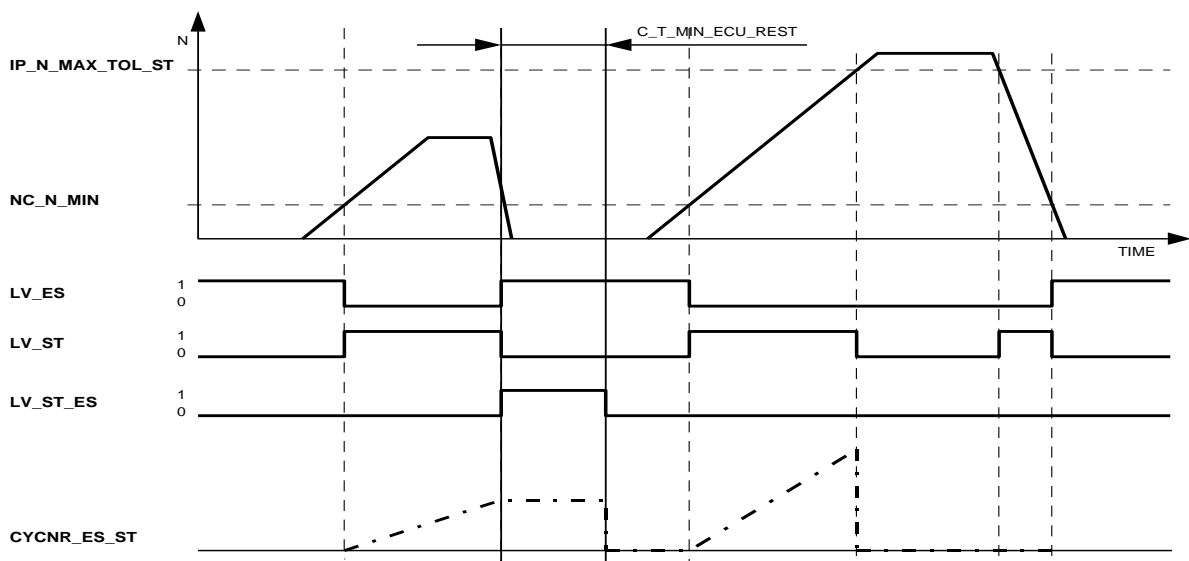

Editor: Müller O.	17-Dec-97	Engine operating states	HMC_V6
Version: a 153589 from 18.12.97		657765.49.04	
File: CHAP_5.DOC	650H0000	Sourcefile:07500402.00I	Page 31 / 43

Proprietary data, company confidential. All rights reserved.
 Contit a titre de secret d'entreprise. Tous droits réservés.
 Comunicado como segredo empresarial. Reservados todos os direitos.
 Confidado como secreto industrial. Nos reservamos todos los derechos.

Weitergabe sowie Vervielfältigung dieser Unterlage, Verwertung und Mitteilung ihres Inhalts nicht gestattet, soweit nicht ausdrücklich zugestanden. Zuwiderhandlungen verpflichten zu Schadensersatz. Alle Rechte vorbehalten, insbesondere für den Fall der Patenterteilung oder GM-Enttragung

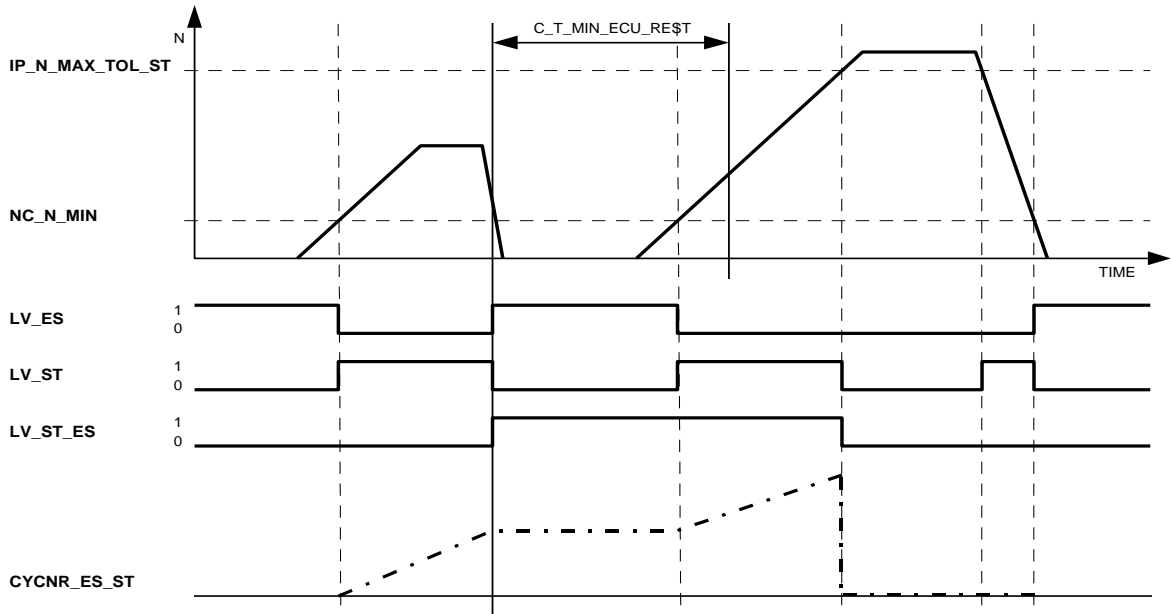

Remark :

If **C_T_MIN_ECU_REST** is greater than **C_T_MAX_ECU** the housekeeping phase is extended to **C_T_MIN_ECU_REST**.

Calibration data:

Name	Dim	Hex. limits	Phys. limits	Resol.	Unit
C_T_MIN_ECU_REST	1	1...FFFFH	0,01...655,35	0,01	sec
Time threshold to detect new start after start-break off.					

Editor: Müller O.	17-Dec-97	Engine operating states	HMC_V6
Version: a 153589 from 18.12.97		657765.49.04	
File: CHAP_5.DOC	650H0000	Sourcefile:07500402.00I	Page 32 / 43

1.4.2 Restart detection function (LV_REST)

Output data:

Name	Mode	Hex. limits	Phys. limits	Resol.	Unit
LV_REST	V	0...01H	0...1	1	-
Auxiliary function " Restart " - (Passive / Active).					

Input data:

TCO	TCO_REST	LV_ST	LV_IS
LV_PL	LV_ST_ES	LV_ES	C_T_MIN_ECU_REST
C_T_MAX_ECU	CYCNR_ES_ST		

FUNCTION DESCRIPTION:

General information:

The restart function is requested as an injection time correction during start and after start phase.

Application conditions:

LV_REST is updated each **500 ms** at engine stop (LV_ES = 1).

There are 4 possible combinations regarding start - restart timing sequence:

a.) Case 1:

After start break-off is detected, LV_ST_ES is set to 1 (see chapter 1.4.1). This case is not considered as a restart and therefore the restart-flag LV_REST is set to **0**.

If a new start takes place before the timer has elapsed or before the end of the housekeeping-phase the factor IP_TIPR_FAC_ST_ES_TCO will be applied on preinjection time (see chapter „Injection“) at the next start and the calculation of start injection time deactivation factor will start with the previous freezed CYCNR_ES_ST-value.

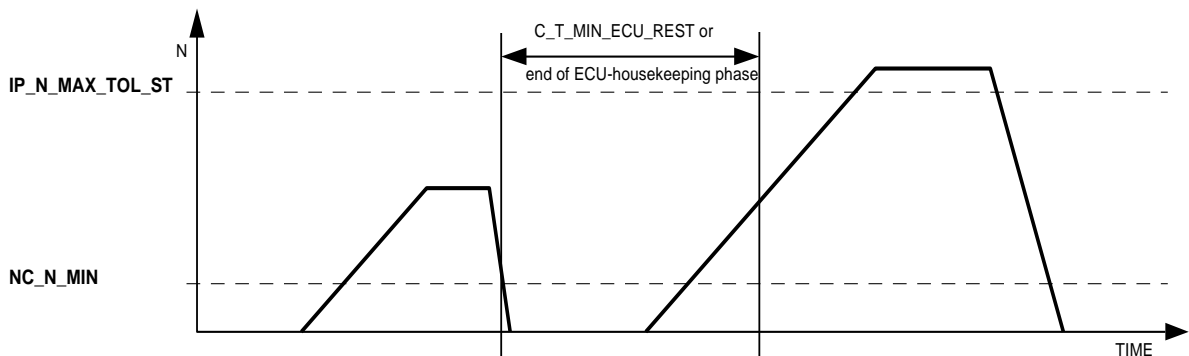

Editor: Müller O.	17-Dec-97	Engine operating states	HMC_V6
Version: a 153589 from 18.12.97		657765.49.04	
File: CHAP_5.DOC	650H0000	Sourcefile:07500402.00I	Page 33 / 43

Proprietary data, company confidential. All rights reserved. Contine a titre de secret d'entreprise. Tous droits réservés. Comunicado como segredo empresarial. Reservados todos os direitos. Confidado como secreto industrial. Nos reservamos todos los derechos.

Weitergabe sowie Vervielfältigung dieser Unterlage, Verwertung und Mitteilung ihres Inhalts nicht gestattet, soweit nicht ausdrücklich zugestanden. Zuwiderhandlungen verpflichten zu Schadensersatz. Alle Rechte vorbehalten, insbesondere für den Fall der Patenterteilung oder GM-Enttragung.

b.) Case 2:

After start break-off is detected, LV_ST_ES is set to 1 (see chapter 1.4.1). This case is not considered as a restart and therefore the restart-flag LV_REST is set to 0.

If a new start takes place after the timer has elapsed or after the end of the housekeeping-phase no corrections are applied on the injection time.

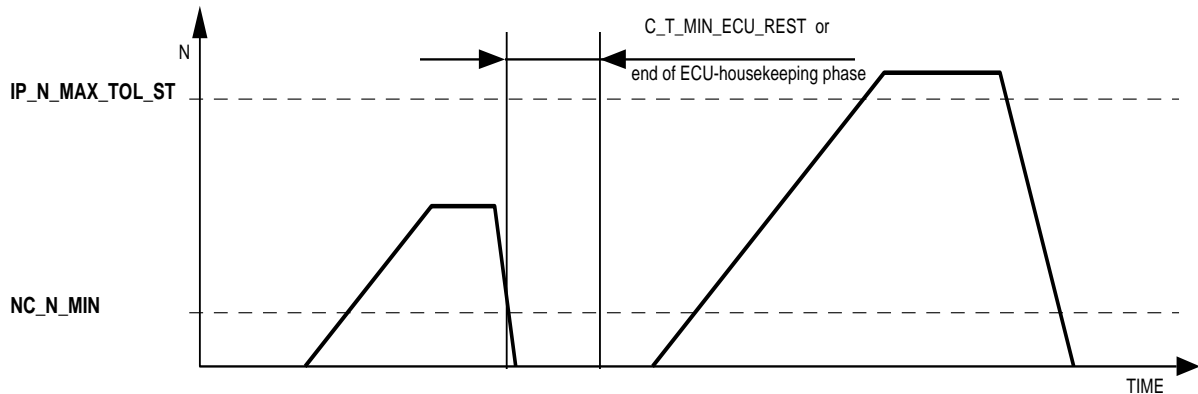

Remark :

The housekeeping phase is extended to C_T_MAX_ECU if C_T_MIN_ECU_REST is greater than C_T_MAX_ECU.

c.) Case 3:

After transition from engine start (LV_ST = 1) to engine stop (LV_ES = 1) LV_REST is checked each 500 ms to the end of the house keeping-phase. As the engine was operated in part load or idle before engine stop, the next start is considered as a restart if following conditions are fulfilled:

```

If          TCO_REST < FFH
and        TCO >= TCO_REST - C_TCO _DIF_MAX_REST

then       LV_REST = 1
else       LV_REST = 0
    
```

Therefore the restart-flag LV_REST is set to 1 during housekeeping phase as long as the coolant temperature did not drop to much.

The calculation of start injection time deactivation factor will start with CYCNR_ES_ST = 0.

Editor: Müller O.	17-Dec-97	Engine operating states	HMC_V6
Version: a 153589 from 18.12.97		657765.49.04	
File: CHAP_5.DOC	650H0000	Sourcefile:07500402.00I	Page 34 / 43

Proprietary data, company confidential. All rights reserved.
 Contine a titre de secret d'entreprise. Tous droits réservés.
 Comunicado como segredo empresarial. Reservados todos os direitos.
 Confidado como secreto industrial. Nos reservamos todos los derechos.

Weitergabe sowie Veröffentlichung dieser Unterlage, Verwertung und Mitteilung ihres Inhalts nicht gestattet, soweit nicht ausdrücklich zugestanden. Zuwiderhandlungen verpflichten zu Schadenersatz. Alle Rechte vorbehalten, insbesondere für den Fall der Patenterteilung oder GM-Enttragung

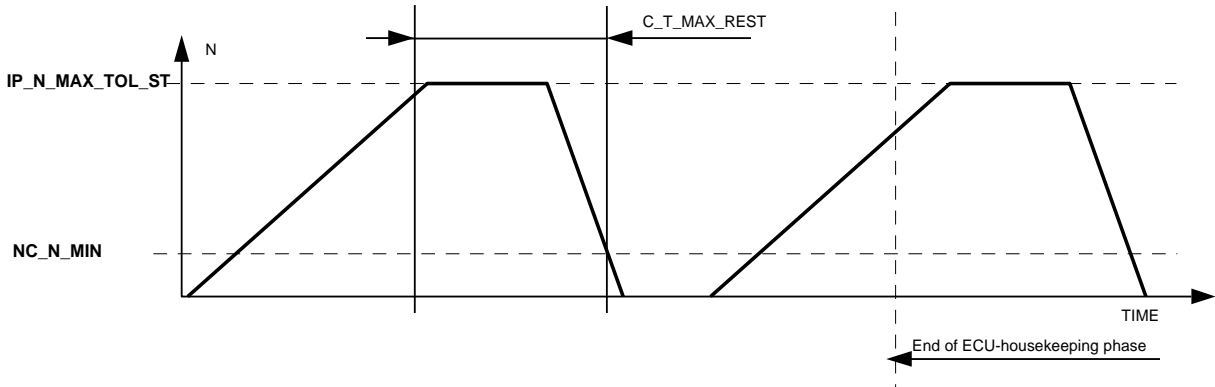

c.) Case 4:

As the next start takes place after the end of the house keeping-phase LV_REST is checked only once at the new start, after receiving the stored TCO_REST from non-volatile memory. As the engine was operated in part load or idle before engine stop, the new start is considered as a restart if following conditions are fulfilled:

```

If          TCO_REST < FFH
and        TCO >= TCO_REST - C_TCO_DIF_MAX_REST

then       LV_REST = 1
else       LV_REST = 0
    
```

Therefore the restart-flag LV_REST is set to **1** before the new start only if TCO did not drop to much. The calculation of start injection time deactivation factor will start with CYCNR_ES_ST = 0.

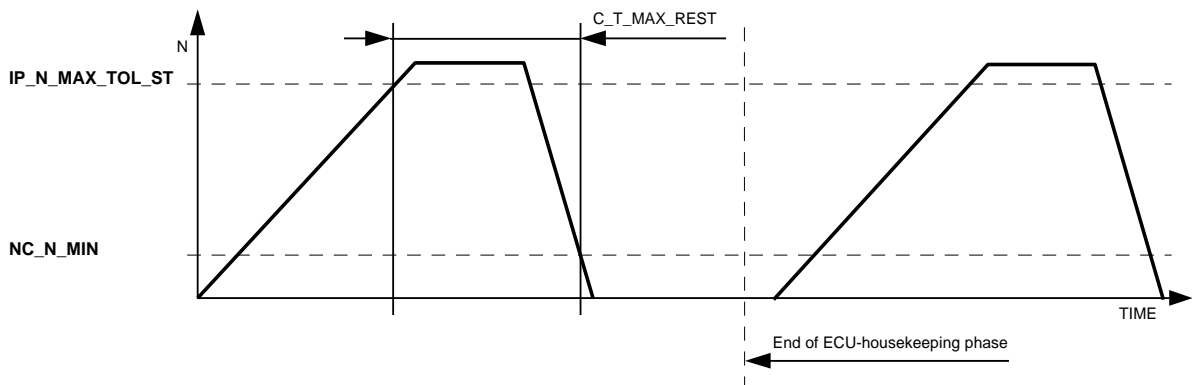

Calibration data:

Name	Dim	Hex. limits	Phys. limits	Resol.	Unit
C_TCO_DIF_MAX_REST	1	0...50H	0...60	0,75	°C
Coolant temperature threshold to detect LV_REST.					

Editor: Müller O.	17-Dec-97	Engine operating states	HMC_V6
Version: a 153589 from 18.12.97		657765.49.04	
File: CHAP_5.DOC	650H0000	Sourcefile:07500402.00I	Page 35 / 43

1.4.3 Post - Start function (LV_TI_AST, LV_IGA_AST)

Output data:

Name	Mode	Hex. limits	Phys. limits	Resol.	Unit
LV_TI_AST	V	0...01H	0..1	1	-
Injection intervention for auxiliary function " Post - Start " - (Passive / Active).					
LV_IGA_AST	V	0...01H	0..1	1	-
Ignition intervention for auxiliary function " Post - Start " - (Passive / Active).					
CYCNR_ST_AST	-	0...FFFFH	0...65535	1	-
Cyclet counter started at transition LV_ST to LV_TI:AST/LV_IGA_AST.					

Input data:

LV_ST	LV_IS	LV_PL	TI_CAST
IGA_DYN_COR_IS	LV_ISAPWM_IS_ACT	N_DIF	

FUNCTION DESCRIPTION:

General information:

The post - start function serves to supply the extra injection quantity required after start by the cold walls of the combustion chamber.

The engine state post - start is requested whenever the engine exits the operating state start (LV_ST) and is executed simultaneously with other engine operating states, except start (LV_ST).

It takes into account an injection time correction (TI_CAST) and an ignition angle intervention (IGA_DYN_COR_IS). At the same time the cycle counter CYCNR_ST_AST is started; it is incremented each segment.

Application conditions:

- *Injection time correction (TI_CAST) due to post start function :*

Activation: **LV_TI_AST = 1** (Active) :

It is activated as soon as the engine operating state start (LV_ST) is exited to go to the engine operating states idle speed (LV_IS) or part load (LV_PL).

Deactivation : **LV_TI_AST = 0** (Passive) :

The injection time enrichment corresponding to post - start (TI_CAST) is complete, i.e. the deactivation factor has elapsed.

- *Ignition angle intervention (IGA_DYN_COR_IS) due to post start function :*

If LV_ST → LV_IS *(engine operating state in idle for the first time)*
and N_DIF < 0 *(engine speed above nominal idle speed)*
and LV_ISAPWM_IS_ACT = 0 (Passive) *(idle speed regulation passive)*
then LV_IGA_AST = 1 (Active)
else LV_IGA_AST = 0 (Passive)

Editor: Müller O.	17-Dec-97	Engine operating states	HMC_V6
Version: a 153589 from 18.12.97		657765.49.04	
File: CHAP_5.DOC	650H0000	Sourcefile:07500402.001	Page 36 / 43

Proprietary data, company confidential. All rights reserved.
 Contient des données confidentielles. Tous droits réservés.
 Comunicado como secreto empresarial. Reservados todos los derechos.
 Confidado como secreto industrial. Nos reservamos todos los derechos.

Weitergabe sowie Vervielfältigung dieser Unterlage, Verwertung und Mitteilung ihres Inhalts ist gestattet, soweit nicht ausdrücklich zugestanden. Zuwiderhandlungen verpflichten zu Schadensersatz. Alle Rechte vorbehalten, insbesondere für den Fall der Patenterteilung oder GM-Enttragung.

1.4.4 Warm - Up function (LV_WUP)

Output data:

Name	Mode	Hex. limits	Phys. limits	Resol.	Unit
LV_WUP	V	0...01H	0...1	1	-
Auxiliary function " Warm - Up " - (Passive / Active).					

Input data:

LV_ES	LV_ST	TI_WUP	
-------	-------	--------	--

FUNCTION DESCRIPTION:

General information:

The injection time is corrected with the warm - up enrichment.

Application conditions:

Activation: LV_WUP = 1 (Active)

The state LV_WUP is activated as soon as the engine operating state engine stopped (LV_ES) is disabled (transition LV_ES / LV_ST).

Deactivation: LV_WUP = 0 (Passive)

As soon as the injection time correction TI_WUP (multiplicative term of the basic injection time) has reached 1, the warm - up flag is disabled.

Proprietary data, company confidential. All rights reserved. Contine a titre de secret d'entreprise. Tous droits réservés. Comunicado como segredo empresarial. Reservados todos os direitos. Confidado como secreto industrial. Nos reservamos todos los derechos.

Weitergabe sowie Vervielfältigung dieser Unterlage, Verwertung und Mitteilung ihres Inhalts nicht gestattet, soweit nicht ausdrücklich zugestanden. Zuwiderhandlungen verpflichten zu Schadenersatz. Alle Rechte vorbehalten, insbesondere für den Fall der Patenterteilung oder GM-Enttragung.

Editor: Müller O.	17-Dec-97	Engine operating states	HMC_V6
Version: a 153589 from 18.12.97		657765.49.04	
File: CHAP_5.DOC	650H0000	Sourcefile:07500402.00I	Page 37 / 43

1.4.5 Rich mixture Warm - Up (LV_RWUP)

Output data:

Name	Mode	Hex. limits	Phys. limits	Resol.	Unit
LV_RWUP	V	0...01H	0...1	1	-
Auxiliary function " Rich mixture warm-up " - (Passive / Active).					

Input data:

LV_SAV	LV_RLY_SAP	LV_IS	LV_PL
--------	------------	-------	-------

FUNCTION DESCRIPTION:

General information:

To warm up the catalyst to its service temperature as quickly as possible after the engine has been started, the secondary air function (LV_SAV and LV_RLY_SAP) is used.

The rich mixture warm - up (LV_RWUP) takes effect in connection with the secondary air function.

Refer to major chapter " Auxiliary Functions " for the description of the secondary air function management .

The boolean LV_RWUP is bound to injection time correction.

Refer to major chapter " Injection " for the description of the secondary air injection time correction.

Application conditions:

Activation: LV_RWUP = 1 (Active)

The injection time correction for air secondary function (bound to LV_RWUP) is enabled with a delay after activation of the secondary air pump (LV_SAP). This delay can be applied separately to idle (LV_IS) and part load (LV_PL) :

LV_IS -----> C_T_ON_RWUP_IS
 LV_PL -----> C_T_ON_RWUP

Remark :

If C_T_ON_RWUP_IS ≥ C_T_ON_RWUP
then C_T_ON_RWUP will be used in idle (LV_IS)

If this correction is already enabled on transition from idle (LV_IS) to part load (LV_PL) while however C_T_ON_RWUP has not yet elapsed after activation of the secondary air pump (LV_RLY_SAP), the flag LV_RWUP is reset.

Proprietary data, company confidential. All rights reserved. Contine a titre de secret d'entreprise. Tous droits réservés. Comunicado como segredo empresarial. Reservados todos os direitos. Confidado como secreto industrial. Nos reservamos todos los derechos.

Weitergabe sowie Vervielfältigung dieser Unterlage, Verwertung und Mitteilung ihres Inhalts nicht gestattet, soweit nicht ausdrücklich zugestanden. Zuwiderhandlungen verpflichten zu Schadensersatz. Alle Rechte vorbehalten, insbesondere für den Fall der Patenterteilung oder GM-Enttragung.

Editor: Müller O.	17-Dec-97	Engine operating states	HMC_V6
Version: a 153589 from 18.12.97		657765.49.04	
File: CHAP_5.DOC	650H0000	Sourcefile:07500402.001	Page 38 / 43

Deactivation: LV_RWUP = 0 (Passive)

The injection time correction for air secondary function (bound to LV_RWUP) is disabled as soon as the activation duration for the secondary air pump (LV_RLY_SAP) has elapsed.

Description:

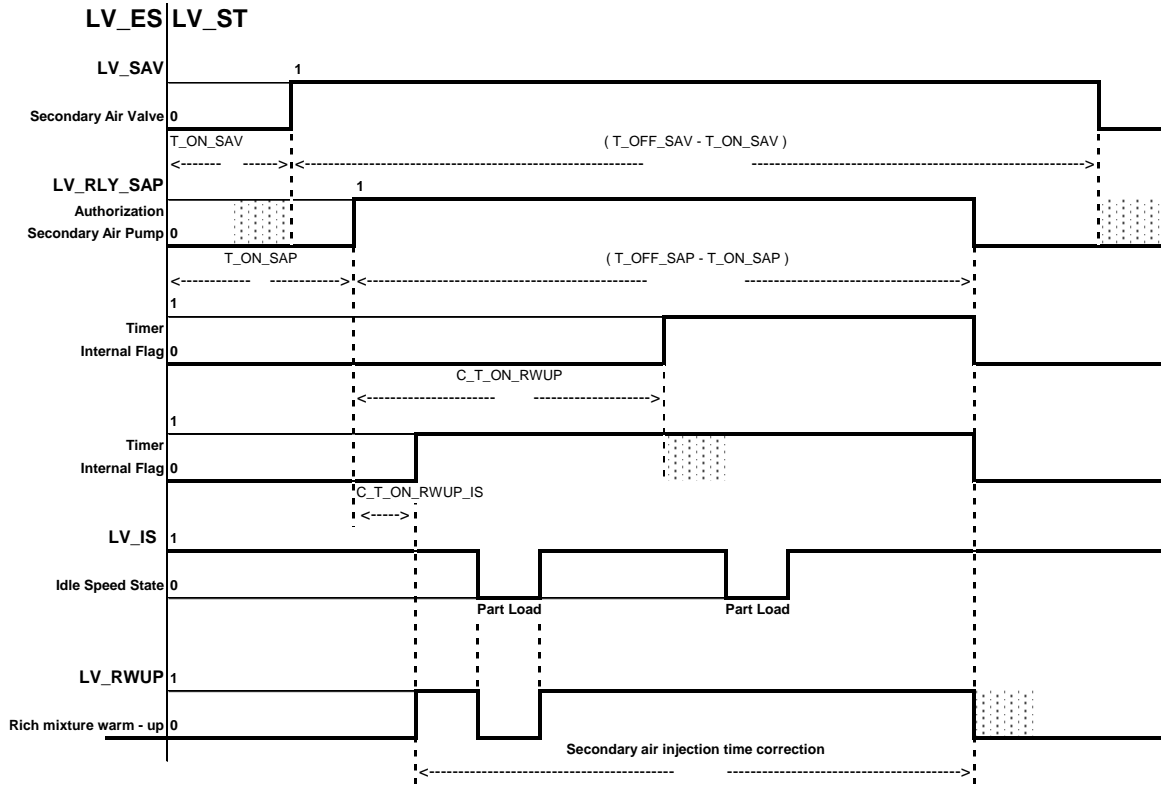

Calibration data:

Name	Dim	Hex. limits	Phys. limits	Resol.	Unit
C_T_ON_RWUP_IS	1	01...FFFFH	0,1...6553,5	0,1	sec.
Duration after authorisation of the air secondary pump in idle to apply the injection time correction for LV_RWUP.					
C_T_ON_RWUP	1	01...FFFFH	0,1...6553,5	0,1	sec.
Duration after authorisation of the air secondary pump in part load to apply the injection time correction for LV_RWUP.					

Editor: Müller O.	17-Dec-97	Engine operating states	HMC_V6
Version: a 153589 from 18.12.97		657765.49.04	
File: CHAP_5.DOC	650H0000	Sourcefile:07500402.001	Page 39 / 43

Proprietary data, company confidential. All rights reserved. Contiene información confidencial. Todos los derechos reservados. Comunicado como secreto empresarial. Reservados todos los derechos. Confidado como secreto industrial. Nos reservamos todos los derechos.

Weitergabe sowie Vervielfältigung dieser Unterlage, Verwertung und Mitteilung ihres Inhalts ist gestattet, soweit nicht ausdrücklich zugestanden. Zuwiderhandlungen verpflichten zu Schadensersatz. Alle Rechte vorbehalten, insbesondere für den Fall der Patenterteilung oder GM-Eintragung.

1.4.6 Catalyst Heating functions (LV_IGA_CH, LV_TI_CH, LV_N_SP_ADD_CH)

Output data:

Name	Mode	Hex. limits	Phys. limits	Resol.	Unit
LV_IGA_CH	V	0...01H	0...1	1	-
Ignition angle correction for catalyst heating active					
LV_TI_CH	V	0...01H	0...1	1	-
Injection time correction for catalyst heating active					
LV_N_SP_ADD_CH	V	0...01H	0...1	1	-
Increased nominal idle speed for catalyst heating function active					

Input data:

LV_ST	LV_IS	LV_TPS_FL	VS
LV_LSCL_1	LV_LSCL_2	LV_MAF_ERR	N_SP_IS
LV_ACIN	TCO_ST		

FUNCTION DESCRIPTION:

General information:

After start, to warm up the catalyst to its service temperature as quickly as possible, the following measures are taken for an adjustable time :

- 1) Increasing the nominal idle speed (N_SP_IS) in idle (LV_IS)
The offset on nominal idle speed is different in Park/Neutral and Drive. An idle speed valve opening correction is linked to the nominal idle speed increase.
(refer to major chapter : "System Variables" and "Idle speed control").
- 2) Calculation of an ignition angle correction (IGA_CH) applied to all engine operating states.
When IGA_CH is applied in Idle, an idle speed valve opening correction is also activated.
(refer to major chapter : "Ignition" and "Idle speed control").
- 3) Adaptation of the injection time (lean correction - TI_CH) depending on the catalyst heating ignition angle intervention (IGA_CH) and the beginning of the lambda control correction.
(refer to major chapter : "Injection").

This functions are activated after Start (LV_ST) during a time which depends on coolant temperature at Start (TCO_ST). The IGA correction has the priority on others functions.

Editor: Müller O.	17-Dec-97	Engine operating states	HMC_V6
Version: a 153589 from 18.12.97		657765.49.04	
File: CHAP_5.DOC	650H0000	Sourcefile:07500402.001	Page 40 / 43

Proprietary data, company confidential. All rights reserved.
 Contient des données confidentielles. Tous droits réservés.
 Comunicado como segredo empresarial. Reservados todos os direitos.
 Confidado como secreto industrial. Nos reservamos todos los derechos.

Weitergabe sowie Vervielfältigung dieser Unterlage, Verwertung und Mitteilung ihres Inhalts ist gestattet, soweit nicht ausdrücklich zugestanden. Zuwiderhandlungen verpflichten zu Schadenersatz. Alle Rechte vorbehalten, insbesondere für den Fall der Patenterteilung oder GM-Enttragung.

Application conditions:

Activation:

* For all the functions: (LV_IGA_CH = LV_TI_CH = LV_N_SP_ADD_CH= 1)

- a) Transition from Start (LV_ST)
- b) **and** no error currently present on MAF (LV_MAF_ERR = 0)

Deactivation:

* Ignition angle intervention and idle speed valve correction :

- a) the duration ID_IGA_T_CH_TCO_ST has elapsed
- b) **or** error currently present on mass air flow sensor (LV_MAF_ERR = 1)
- c) **or** VS > C_IGA_VS_MAX_CH one time
- d) **or** LV_TPS_FL = 1 one time

Thus, **LV_IGA_CH = 0** (Passive)

* Injection time correction :

- a) the duration ID_TI_T_CH_TCO_ST has elapsed
- b) **or** error currently present on mass air flow sensor (LV_MAF_ERR = 1)
- c) **or** the lambda control starts (LV_LSCL_i = 1 (ON))
- d) **or** LV_IGA_CH = 0

Thus, **LV_TI_CH = 0** (Passive)

* Nominal idle speed increase and idle speed valve correction :

- a) the duration ID_N_SP_T_CH_TCO_ST has elapsed
- b) **or** error currently present on mass air flow sensor (LV_MAF_ERR = 1)
- c) **or** LV_ACIN = 1 one time
- d) **or** LV_IGA_CH = 0
- e) **or** Engine operating state PL active during C_N_SP_T_CH seconds one time

Thus, **LV_N_SP_ADD_CH = 0** (Passive)

Editor:	Müller O.	17-Dec-97	Engine operating states	HMC_V6
Version:	a 153589 from 18.12.97		657765.49.04	
File:	CHAP_5.DOC	650H0000	Sourcefile:07500402.00I	Page 41 / 43

Calibration data:

Name	Dim	Hex. limits	Phys. limits	Resol.	Unit
ID_IGA_T_CH__TCO_ST	8	0...FFFFH	0,1...6553,5	0,1	sec.
Duration after start to switch on the ignition angle intervention for catalyst heating function.					
ID_TI_T_CH__TCO_ST	8	0...FFFFH	0,1...6553,5	0,1	sec.
Duration after start to switch on the injection time correction for catalyst heating function.					
ID_N_SP_T_CH__TCO_ST	8	0...FFFFH	0,1...6553,5	0,1	sec.
Duration after start to switch on the nominal idle speed correction for catalyst heating function.					
C_IGA_VS_MAX_CH	-	0...FFH	0...255	1	km/h
Maximum vehicle speed for active catalyst heating function					
C_N_SP_T_CH	-	0...FFFFH	0...655,35	10	msec.
Time in PL to stop catalyst heating function related to nominal idle speed					

Proprietary data, company confidential. All rights reserved.
 Contient des données confidentielles de la société. Tous droits réservés.
 Comunicado como secreto empresarial. Reservados todos los derechos.
 Confidado como secreto industrial. Nos reservamos todos los derechos.

Weitergabe sowie Vervielfältigung dieser Unterlage, Verwertung und Mitteilung ihres Inhalts ist gestattet, soweit nicht ausdrücklich zugestanden. Zuwiderhandlungen verpflichten zu Schadensersatz. Alle Rechte vorbehalten, insbesondere für den Fall der Patenterteilung oder GM-Eintragung.

Editor: Müller O.	17-Dec-97	Engine operating states	HMC_V6
Version: a 153589 from 18.12.97		657765.49.04	
File: CHAP_5.DOC	650H0000	Sourcefile:07500402.00I	Page 42 / 43

1.5 General Drawing

Proprietary data, company confidential. All rights reserved.
 Contití a tíre de secret d'entreprise. Tous droits réservés.
 Comunicado como segredo empresarial. Reservados todos os direitos.
 Confidado como secreto industrial. Nos reservamos todos los derechos.

Weitergabe sowie Vervielfältigung dieser Unterlage, Verwertung und Mitteilung ihres Inhalts nicht gestattet, soweit nicht ausdrücklich zugestanden. Zuwiderhandlungen verpflichten zu Schadensersatz. Alle Rechte vorbehalten, insbesondere für den Fall der Patenterteilung oder GM-Entragung.

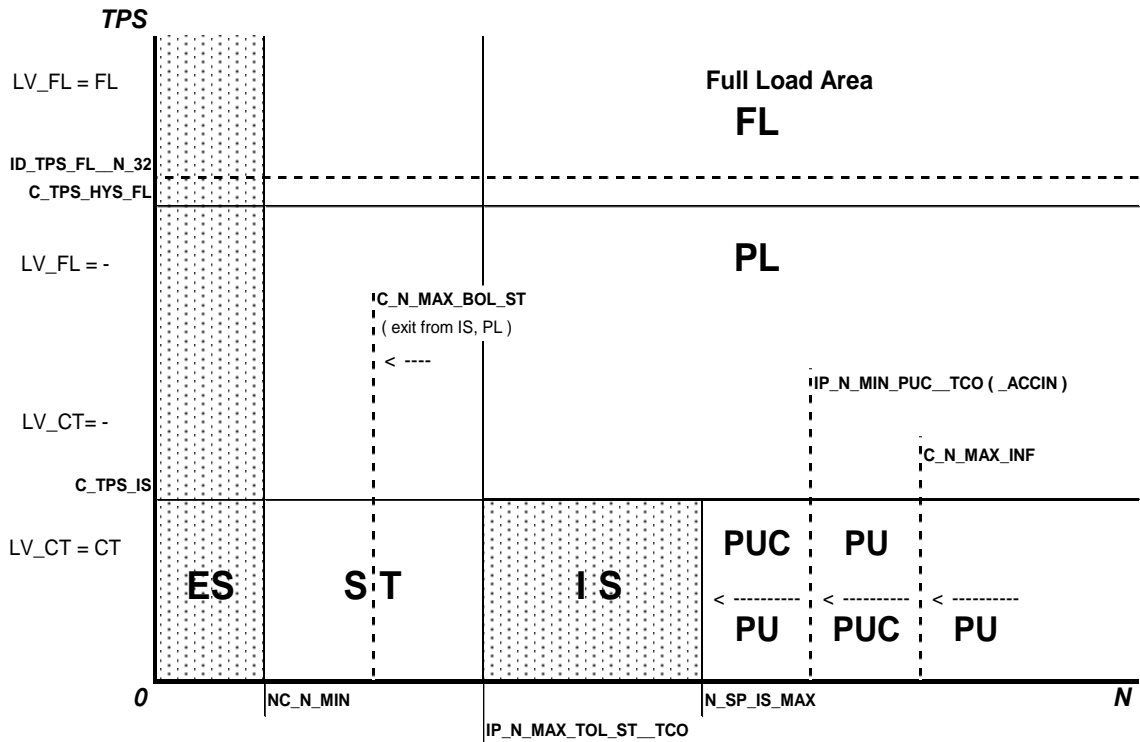

- LV_ES** : Engine Stopped
- LV_ST** : Start
- LV_IS** : Idle Speed
- LV_PL** : Part Load
- LV_PU** : Trailing Throttle
- LV_PUC** : Trailing Throttle Fuel Cut Off
- LV_FL** : Full Load

Editor: Müller O.	17-Dec-97	Engine operating states	HMC_V6
Version: a 153589 from 18.12.97		657765.49.04	
File: CHAP_5.DOC	650H0000	Sourcefile:07500501.00B	Page 43 / 43

Proprietary data, company confidential. All rights reserved.
Confie a titre de secret d'entreprise. Tous droits réservés.
Comunicado como segredo empresarial. Reservados todos os direitos.
Confidado como secreto industrial. Nos reservamos todos los derechos.

Weitergabe sowie Vervielfältigung dieser Unterlage, Verwertung und Mitteilung ihres Inhalts nicht gestattet, soweit nicht ausdrücklich zugestanden. Zuwiderhandlungen verpflichten zu Schadenersatz. Alle Rechte vorbehalten, insbesondere für den Fall der Patenterteilung oder GM-Entragung

Document: **Ignition**

Project: **Engine Management System**
HMC_V6

Version: a

Date: 17-Dec-97

Number of pages: 53

Revision Code-No.: 153589 from 18.12.97

Construction protocol-No.:

Software version: 650H0000

	Name	Department	Phone	Date	Sign
Author	Müller O.	AT PT SI TSA 11	3211	09.12.97	
1. Check	Pioch O.	AT PT SI TSA 11	3212	09.12.97	
2. Check	Gessner S.	AT PT SI TSA 11	5398	09.12.97	
Responsible	Brückner D.	AT PT SI TSA 16	4279	09.12.97	

Version list

Version	Date	Author	Comment, Description

Proprietary data, company confidential. All rights reserved. Contine a titre de secret d'entreprise. Tous droits réservés. Comunicado como segredo empresarial. Reservados todos os direitos. Confidado como secreto industrial. Nos reservamos todos los derechos.

Weitergabe sowie Vervielfältigung dieser Unterlage, Wertung und Mitteilung ihres Inhalts nicht gestattet, soweit nicht ausdrücklich zugestanden. Zuwiderhandlungen verpflichten zu Schadensersatz. Alle Rechte vorbehalten, insbesondere für den Fall der Patenterteilung oder GM-Eintragung

Editor:	Müller O.	17-Dec-97	Ignition	HMC_V6
Version:	a 153589 from 18.12.97		657765.49.05	
File:	CHAP_6.DOC	650H0000		Page 2 / 53

Table of contents

Page

1.1	General	11
1.1.1	Total formulas	11
1.1.1.1	Ignition angle calculation (IGA_CYL_[CYL] , IGA_SAM)	11
1.1.1.1.1	Cranking ignition angle calculation	11
1.1.1.1.1.1	First ignition angle at engine stopped (LV_ES)	11
1.1.1.1.1.2	Ignition angle at start (LV_ST)	11
1.1.1.1.2	Nominal ignition angle (out of start) calculation	12
1.1.1.1.2.1	Basic ignition angle without gradient limitation (IGA_BAS)	12
1.1.1.1.2.2	Global ignition angle correction (IGA_ADD_COR)	12
1.1.1.1.2.3	Ignition angle out of start without torque intervention (IGA_CYL_[CYL])	12
1.1.1.2	Ignition angle application (IGA_IGC_[CYL], IGA_IGC_SAM)	14
1.2	Calculation of ignition angle corrections	15
1.2.1	Dynamic ignition angle correction in idle (IGA_DYN_COR_IS)	15
1.2.2	Air and coolant temperatures correction out of idle (IGA_TIA_TCO)	17
1.2.3	Catalyst heating correction (IGA_CH)	18
1.2.4	Instationary correction (IGA_TRA_KNK)	20
1.2.5	Anti - jerk correction (IGA_AJ)	22
1.2.6	Trailing throttle correction (IGA_PU_PUC)	27
1.2.7	Tuning correction (IGA_AS_[CYL])	32
1.3	Calculation of basic ignition angle	33
1.3.1	Basic ignition angle at start (IGA_ST)	33
1.3.2	Basic ignition angle out of start (IGAB)	34
1.3.3	Basic ignition angle with gradient limitation (IGA_BAS_LGRD)	35
1.3.3.1	Engine operating states without gradient limitation for ignition angle.	35
1.3.3.	2 Gradient limitation for ignition angle at intercept function (LV_INF)	36
1.3.3.3	Re-start fuel feed (LV_REAC) at part load (LV_PUC → LV_PL)	37
1.3.3.4	Re-start fuel feed (LV_REAC) at idle (LV_PUC → (LV_PU)→ LV_IS)	39
1.3.3.5	Gradient limitation for ignition angle with anti-jerk correction (LV_AJ_ACT)	41
1.3.3.6	Gradient limitation for ignition angle with instationary correction (LV_TRA_KNK_ACT)	42
1.3.3.7	Gradient limitation for ignition angle with knock detected	43
1.3.3.8	Gradient limitation for transition Part Load (PL) -> Idle Speed (IS)	43
1.3.3.9	General gradient limitation for ignition angle	44
1.4	Knock control	46
1.4.1	General - Knock correction (IGA_KNK_[CYL])	46
1.4.1.1	Conditions for knock control in normal operation or in limp home	46
1.4.1.2	Ignition angle correction out of knock detection area	46
1.4.1.3	Ignition angle knock correction mean value (IGA_MV_KNK)	47
1.4.1.4	Relative knock corrections limitation	47
1.4.1.5	Absolute knock corrections limitation	47
1.4.2	Knock control in normal operation	49
1.4.3	Knock control in limp home	50
1.4.4	Knock adaptation	51

Proprietary data, company confidential. All rights reserved.
 Contient des données confidentielles de la société. Tous droits réservés.
 Comunicado como secreto empresarial. Reservados todos los derechos.
 Confiado como secreto industrial. Nos reservamos todos los derechos.

Weitergabe sowie Vervielfältigung dieser Unterlage, Verbreitung und Mitteilung ihres Inhalts nicht gestattet, soweit nicht ausdrücklich zugestanden. Zuwiderhandlungen verpflichten zu Schadensersatz. Alle Rechte vorbehalten, insbesondere für den Fall der Patenterteilung oder GM-Entragung.

Editor:	Müller O.	17-Dec-97	Ignition	HMC_V6
Version:	a 153589 from 18.12.97		657765.49.05	
File:	CHAP_6.DOC	650H0000		Page 3 / 53

Index

Page

:

C

C_DRI_TPS_GRD_MIN_AJ
def.....26

C_IGA_AD_DIF_MAX
def.....50

C_IGA_AS_[CYL]
def.....32

C_IGA_DIF_MAX_MIN_KNK
def.....48

C_IGA_FAC_2_AJ
def.....26

C_IGA_FAC_3_AJ
def.....26

C_IGA_INC_AD
def.....53

C_IGA_LGRD_1
def.....45
use.....36, 37, 39

C_IGA_LGRD_2
def.....45
use.....37, 39, 42

C_IGA_LGRD_3
def.....45
use.....37, 39, 46

C_IGA_LGRD_CH
def.....19

C_IGA_LGRD_PL_IS
def.....43

C_IGA_LGRD_x
use.....27

C_IGA_MAF_LGRD
def.....45

C_IGA_N_DIF_FAC_IS
def.....16

C_IGA_N_LGRD
def.....45

C_N_GRD_MIN
use.....27

C_N_MAX_AJ
def.....26

C_N_MAX_INF
use.....27

C_N_MIN_AJ
def.....26

C_N_MIN_DHP
def.....31

C_N_THD_T_MES_AJ
def.....26

C_SUM_TRIG_AJ
def.....26

Proprietary data, company confidential. All rights reserved.
 Contit a titre de secret d'entreprise. Tous droits réservés.
 Comunicado como segredo empresarial. Reservados todos os direitos.
 Confidado como secreto industrial. Nos reservamos todos los derechos.

Weitergabe sowie Vervielfältigung dieser Unterlage, Verwertung und Mitteilung ihres Inhalts nicht gestattet, soweit nicht ausdrücklich zugestanden. Zuwiderhandlungen verpflichten zu Schadensersatz. Alle Rechte vorbehalten, insbesondere für den Fall der Patenterteilung oder GM-Entragung

Editor:	Müller O.	17-Dec-97	Ignition	HMC_V6
Version:	a 153589 from 18.12.97		657765.49.05	
File:	CHAP_6.DOC	650H0000		Page 4 / 53

Proprietary data, company confidential. All rights reserved.
 Contit a titre de secret d'entreprise. Tous droits réservés.
 Comunicado como secreto empresarial. Reservados todos os direitos.
 Confidado como secreto industrial. Nos reservamos todos los derechos.

Weitergabe sowie Vervielfältigung dieser Unterlage, Verwertung und Mitteilung ihres Inhalts nicht gestattet, soweit nicht ausdrücklich zugestanden. Zuwiderhandlungen verpflichten zu Schadenersatz. Alle Rechte vorbehalten, insbesondere für den Fall der Patenterteilung oder GM-Entragung

C_T_MAX_AJ	
def.....	26
C_T_MAX_GRD_2_ST_AJ	
def.....	26
C_T_TPS_GRD_MIN_AJ	
def.....	26
C_TCO_MIN_AJ	
def.....	26
C_TPS_GRD_BOL_RPL	
def.....	38
use.....	20
C_TPS_GRD_MIN_AJ	
def.....	26
C_VS_MAX_AJ	
def.....	26
C_VS_MIN_AJ	
def.....	26
I	
ID_IGA_AD_[CYL]__N_KNK__MAF_KNK	
def.....	53
use.....	49
ID_IGA_CYCNR_TRA_KNK(_AT)__N_32	
def.....	21
ID_IGA_DEC_1_KNK__N_KNK	
def.....	50
ID_IGA_DEC_2_KNK__N_KNK	
def.....	50
ID_IGA_INC_KNK__N_KNK	
def.....	50
ID_IGA_LGRD_END_AJ__N_32	
def.....	41
use.....	22
ID_IGA_LGRD_RPL__N_32	
def.....	38
ID_IGA_LGRD_ST_AJ__N_32	
def.....	26
ID_IGA_MIN_PL__TCO	
def.....	14
ID_IGA_RPL__N_32__TCO	
def.....	38
use.....	20
ID_IGA_T_CH__TCO_ST	
use.....	18
ID_IGA_TCO_LGRD_PU(_AT)__TCO	
def.....	31
ID_IGA_TPS_GRD_TRA__N_32	
def.....	21
use.....	39
ID_IGA_TRA_KNK(_AT)__N_32__MAF	
def.....	21
ID_MAF_MIN_AD_KNK__N_32	
def.....	53
IGA_ADD_COR	
def.....	11
IGA_AJ	
def.....	22

Editor: Müller O.	17-Dec-97	Ignition	HMC_V6
Version: a 153589 from 18.12.97		657765.49.05	
File: CHAP_6.DOC	650H0000		Page 5 / 53

use.....	11, 41
IGA_AS_[CYL]	
def.....	32
use.....	11
IGA_BAS	
def.....	11
use.....	35, 36, 37, 39, 41, 42, 43, 44
IGA_BAS_LGRD	
def.....	35
use.....	11
IGA_CAT	
use.....	11
IGA_CH	
def.....	18
use.....	46
IGA_CYL_[CYL]	
def.....	11
IGA_DYN_COR_IS	
def.....	15
use.....	11
IGA_EGR	
use.....	11
IGA_IGC_[CYL]	
def.....	11
IGA_IGC_SAM	
def.....	11
IGA_KNK_[CYL]	
def.....	46
use.....	11, 49
IGA_MV_KNK	
def.....	46
use.....	51
IGA_PU_PUC	
def.....	27
use.....	11
IGA_SAM	
def.....	11
IGA_ST	
def.....	33
use.....	11
IGA_TIA_TCO	
def.....	17
use.....	11
IGA_TQR	
use.....	11
IGA_TRA_KNK	
def.....	20
use.....	11, 37, 39, 42
IGAB	
def.....	34
use.....	11
IP_IGA_ACCIN_PUC(_AT)_N	
def.....	31
IP_IGA_AJ_N_32_MAF	
def.....	26
IP_IGA_AST_N_DIF_COR	
def.....	16

Editor: Müller O.	17-Dec-97	Ignition	HMC_V6
Version: a 153589 from 18.12.97		657765.49.05	
File: CHAP_6.DOC	650H0000		Page 6 / 53

Proprietary data, company confidential. All rights reserved.
 Contient des informations confidentielles. Tous droits réservés.
 Comunicado como segredo empresarial. Reservados todos os direitos.
 Confidado como secreto industrial. Nos reservamos todos los derechos.

Weitergabe sowie Vervielfältigung dieser Unterlage, Verwertung und Mitteilung ihres Inhalts ist gestattet, soweit nicht ausdrücklich zugestanden. Zuwiderhandlungen verpflichten zu Schadensersatz. Alle Rechte vorbehalten, insbesondere für den Fall der Patenterteilung oder GM-Enttragung.

IP_IGA_CH_N_32_MAF	19
def.....	19
IP_IGA_CH_IS_N_32_MAF	19
def.....	19
IP_IGA_FAC_IS(AT)_TCO	16
def.....	16
IP_IGA_LGRD_PU(AT)_N_32_MAF_MMV	31
def.....	31
IP_IGA_LGRD_RIS_N_GRD	40
def.....	40
IP_IGA_MAX_KNK_N_32_MAF	48
def.....	48
IP_IGA_MAX_PUC_N	31
def.....	31
IP_IGA_N_DIF_IS(AT)_N_DIF_COR	16
def.....	16
IP_IGA_N_MAF_N_32_MAF	17
def.....	17
IP_IGA_PU(AT)_N_TCO	31
def.....	31
IP_IGA_PUC(AT)_N	31
def.....	31
IP_IGA_ST_N_TCO_ST	33
def.....	33
IP_IGA_TCO_CH_TCO_T_AST	19
def.....	19
IP_IGA_TCO_CH_IS_TCO_T_AST	19
def.....	19
IP_IGA_TCO_FAC_KNK_TCO	48
def.....	48
IP_IGA_TCO_IS_TCO	34
def.....	34
IP_IGA_TRA_FAC(AT)_TIA	21
def.....	21
IP_IGAB_N_MAF	34
def.....	34
IP_IGAB_INF_TCO	36
def.....	36
IP_IGAB_IS_N_MAF	34
def.....	34
IP_N_ACCIN_MIN_PUC(AT)_TCO	27
use.....	27
IP_N_MIN_PUC(AT)_TCO	27
use.....	27
IP_T_MES_GRD_1_ST_AJ_N_32	26
def.....	26
IP_T_MES_GRD_2_ST_AJ_N_32	26
def.....	26
IP_T_MES_GRD_END_AJ_N_32	26
def.....	26
IP_TIA_TCO_FAC(AT)_TIA_TCO	17
def.....	17
ISAPWM_D_IS	27
use.....	27
ISAPWM_DHP	27
use.....	27

Editor: Müller O.	17-Dec-97	Ignition	HMC_V6
Version: a 153589 from 18.12.97		657765.49.05	
File: CHAP_6.DOC	650H0000		Page 7 / 53

Proprietary data, company confidential. All rights reserved.
 Contine a titre de secret d'entreprise. Tous droits réservés.
 Comunicado como segredo empresarial. Reservados todos os direitos.
 Confidado como secreto industrial. Nos reservamos todos los derechos.

Weitergabe sowie Vervielfältigung dieser Unterlage, Verwertung und Mitteilung ihres Inhalts nicht gestattet, soweit nicht ausdrücklich zugestanden. Zuwiderhandlungen verpflichten zu Schadensersatz. Alle Rechte vorbehalten, insbesondere für den Fall der Patenterteilung oder GM-Enttragung.

K

KNK_INT_CYL_[CYL]	
use.....	43, 49
KNKS_[CYL]	
use.....	49

L

LV_AJ_ACT	
def.....	22
use.....	41
LV_CAM_ERR	
use.....	22, 51
LV_CAM_ERR_LIH	
use.....	46
LV_CRK_ERR	
use.....	22, 51
LV_CRK_ERR_LIH	
use.....	46
LV_CT	
use.....	27
LV_CYC_WUP_KNK	
def.....	51
LV_DRI	
use.....	22
LV_DUR_IGC_[CYL]_ERR	
use.....	22
LV_ES	
use.....	11, 33
LV_IGA_AD_ACT	
def.....	51
LV_IGA_ADJ_TQR	
use.....	46, 49, 51
LV_IGA_AST	
use.....	15, 35
LV_IGA_CH	
use.....	18, 46, 51
LV_INF	
use.....	36
LV_IS	
use.....	11, 15, 18, 34, 39, 43, 51
LV_ISA_1_ERR	
use.....	51
LV_ISA_2_ERR	
use.....	51
LV_ISAPWM_IS_ACT	
use.....	15, 35
LV_IV_[CYL]_ERR	
use.....	22
LV_KNK_1_ERR	
use.....	46, 51
LV_KNK_2_ERR	
use.....	46, 51
LV_KNK_ACT	
use.....	46, 49, 51
LV_LSH_UP_1_ERR	
use.....	51
LV_LSH_UP_2_ERR	

Editor: Müller O.	17-Dec-97	Ignition	HMC_V6
Version: a 153589 from 18.12.97		657765.49.05	
File: CHAP_6.DOC	650H0000		Page 8 / 53

Proprietary data, company confidential. All rights reserved.
 Contient des données confidentielles de l'entreprise. Tous droits réservés.
 Comunicado como secreto empresarial. Reservados todos los derechos.
 Confiado como secreto industrial. Nos reservamos todos los derechos.

Weitergabe sowie Vervielfältigung dieser Unterlage, Wertung und Mitteilung ihres Inhalts nicht gestattet, soweit nicht ausdrücklich zugestanden. Zuwiderhandlungen verpflichten zu Schadensersatz. Alle Rechte vorbehalten, insbesondere für den Fall der Patenterteilung oder GM-Enttragung

use.....	51
LV_MAF_ERR	
use.....	51
LV_N_GRD_INF	
use.....	36
LV_N_GRD_MAX_KNK	
use.....	51
LV_PL	
use.....	11, 20, 22, 27, 37, 39, 43
LV_PU	
use.....	11, 27, 39
LV_PU_PUC_TRA_FAST	
use.....	27
LV_PUC	
use.....	11, 20, 27, 35, 37, 39
LV_REAC	
use.....	20, 37, 39
LV_RLY_ACCOUT	
use.....	27
LV_SCC_TQR	
use.....	51
LV_ST	
use.....	11, 15, 33, 35
LV_STATE_A_MIS	
use.....	22, 51
LV_STATE_B_MIS	
use.....	22, 51
LV_SYN_ENG	
use.....	11
LV_TCO_ERR	
use.....	51
LV_TIA_ERR	
use.....	51
LV_TPS_ERR	
use.....	51
LV_TPS_FL	
use.....	18, 46, 51
LV_TPS_GRD_TRA_KNK	
use.....	51
LV_TRA_KNK_ACT	
def.....	20
use.....	37, 39, 42, 46, 49
LV_TRA_TPS_GRD_MIN_AJ	
def.....	22
LV_VLS_LIM_1_ERR	
use.....	51
LV_VLS_LIM_2_ERR	
use.....	51
M	
MAF	
use.....	17, 18, 20, 22, 34, 44
MAF_KNK	
use.....	49, 51
MAF_MMV	
use.....	27

Editor: Müller O.	17-Dec-97	Ignition	HMC_V6
Version: a 153589 from 18.12.97		657765.49.05	
File: CHAP_6.DOC	650H0000		Page 9 / 53

Proprietary data, company confidential. All rights reserved.
 Contient des données confidentielles. Tous droits réservés.
 Comunicado como segredo empresarial. Reservados todos os direitos.
 Confidado como secreto industrial. Nos reservamos todos los derechos.

Weitergabe sowie Vervielfältigung dieser Unterlage, Verwertung und Mitteilung ihres Inhalts ist gestattet, soweit nicht ausdrücklich zugestanden. Zuwiderhandlungen verpflichten zu Schadensersatz. Alle Rechte vorbehalten, insbesondere für den Fall der Patenterteilung oder GM-Entragung

N	
N	
use.....	22, 27, 33, 34, 44
N_32	
use.....	17, 18, 20, 22, 27, 34, 37, 39, 41, 51
N_DIF_COR	
use.....	15
N_GRD	
use.....	27, 39
N_KNK	
use.....	49, 51
NC_CYL_NO	
def.....	48
NC_INI_IGA	
def.....	14
NL_THD_KNK_[CYL]	
use.....	49
S	
SUM_TRIG_AJ	
def.....	22
T	
T_AST	
use.....	18
T_MES_GRD_AJ	
def.....	22
T_SEG	
use.....	22
TCO	
use.....	15, 17, 18, 20, 22, 27, 34, 36, 37
TCO_ST	
use.....	33
TIA	
use.....	17, 20
TPS_GRD	
use.....	20, 22, 37, 39
V	
VS	
use.....	15, 22

Editor:	Müller O.	17-Dec-97	Ignition	HMC_V6
Version:	a 153589 from 18.12.97		657765.49.05	
File:	CHAP_6.DOC	650H0000		Page 10 / 53

1.1 General

1.1.1 Total formulas

Output data:

Name	Mode	Hex. limits	Phys. limits	Resol.	Unit
IGA_BAS	V	0...FFH	-23,625...72	0,375	°CRK
Basic ignition angle calculation without gradient limitation.					
IGA_ADD_COR	-	0...FFH	-23,625...72	0,375	°CRK
Global ignition angle correction.					
IGA_CYL_[CYL]	V	0...FFH	72...-23,625	0,375	°CRK
Individual ignition angle calculation without torque intervention.					
IGA_SAM	V	0...FFH	72...-23,625	0,375	°CRK
Individual ignition angle calculation without torque intervention updated each segment.					
IGA_IGC_[CYL]	V	0...FFH	72...-23,625	0,375	°CRK
Individual applied ignition angle with torque intervention.					
IGA_IGC_SAM	V	0...FFH	72...-23,625	0,375	°CRK
Individual applied ignition angle with torque intervention updated each segment.					

Input data:

LV_SYN_ENG	LV_ES	LV_ST	IGA_ST
IGA_KNK_[CYL]	IGA_AS_[CYL]	IGAB	IGA_DYN_COR_IS
IGA_TIA_TCO	IGA_CAT	IGA_EGR	IGA_TQR
IGA_TRA_KNK	IGA_AJ	IGA_PU_PUC	IGA_BAS_LGRD
LV_IS	LV_PU	LV_PUC	LV_PL

1.1.1.1 Ignition angle calculation (IGA_CYL_[CYL] , IGA_SAM)

1.1.1.1.1 Cranking ignition angle calculation

1.1.1.1.1.1 First ignition angle at engine stopped (LV_ES)

If LV_SYN_ENG = 1 (synchronisation effective)
and engine stopped (LV_ES)
then IGA_CYL_[CYL] = NC_INI_IGA

1.1.1.1.1.2 Ignition angle at start (LV_ST)

IGA_CYL_[CYL] = IGA_ST Cranking ignition angle.
 + IGA_KNK_[CYL] Knock correction.
 + IGA_AS_[CYL] Application system intervention.

Application recurrence : **Segment**

Editor: Müller O.	17-Dec-97	Ignition	HMC_V6
Version: a 153589 from 18.12.97		657765.49.05	
File: CHAP_6.DOC	650H0000	Sourcefile:07600101.00C	Page 11 / 53

Proprietary data, company confidential. All rights reserved. Contient des informations confidentielles. Tous droits réservés. Comunicado como secreto empresarial. Reservados todos los derechos. Confidado como secreto industrial. Nos reservamos todos los derechos.

Weitergabe sowie Vervielfältigung dieser Unterlage, Wertung und Mitteilung ihres Inhalts nicht gestattet, soweit nicht ausdrücklich zugestanden. Zuwiderhandlungen verpflichten zu Schadensersatz. Alle Rechte vorbehalten, insbesondere für den Fall der Patenterteilung oder GM-Eintragung.

1.1.1.1.2 Nominal ignition angle (out of start) calculation

1.1.1.1.2.1 Basic ignition angle without gradient limitation (IGA_BAS)

$$\begin{aligned}
 \text{IGA_BAS} &= \text{IGAB} && \text{Basic ignition angle.} \\
 &+ \min (\text{IGA_ADD_COR}, && \text{Global ignition angle correction.} \\
 &\text{IGA_AJ}) && \text{Anti-jerk correction.}
 \end{aligned}$$

Application recurrence : **Segment**

1.1.1.1.2.2 Global ignition angle correction (IGA_ADD_COR)

$$\begin{aligned}
 \text{IGA_ADD_COR} &= \text{IGA_DYN_COR_IS} && \text{Dynamic correction in idle (LV_IS)} \\
 &+ \text{IGA_TIA_TCO} && \text{Air and coolant temperatures correction.} \\
 &+ \text{IGA_CH} && \text{Catalyst heating correction.} \\
 &+ \text{IGA_EGR} && \text{EGR correction.} \\
 &+ \text{IGA_TRA_KNK} && \text{Instationary correction.} \\
 &+ \text{IGA_PU_PUC} && \text{Trailing throttle correction (LV_PU / LV_PUC)}
 \end{aligned}$$

Application recurrence : **Segment**

1.1.1.1.2.3 Ignition angle out of start without torque intervention (IGA_CYL_[CYL])

$$\begin{aligned}
 \text{IGA_CYL_}[CYL] &= \text{IGA_BAS_LGRD} && \text{Basic ignition angle with gradient limitation.} \\
 &+ \text{IGA_KNK_}[CYL] && \text{Knock correction.} \\
 &+ \text{IGA_AS_}[CYL] && \text{Application system intervention.}
 \end{aligned}$$

Application recurrence : **Segment**

See next page for illustration.

Remark :

The basic ignition angle with gradient limitation IGA_BAS_LGRD is described in chapter 1.1.2.

Editor:	Müller O.	17-Dec-97	Ignition	HMC_V6
Version:	a 153589 from 18.12.97		657765.49.05	
File:	CHAP_6.DOC	650H0000	Sourcefile:07600101.00C	Page 12 / 53

Proprietary data, company confidential. All rights reserved. Contine a titre de secret d'entreprise. Tous droits réservés. Comunicado como segredo empresarial. Reservados todos os direitos. Confidado como secreto industrial. Nos reservamos todos los derechos.

Weitergabe sowie Vervielfältigung dieser Unterlage, Verwertung und Mitteilung ihres Inhalts nicht gestattet, soweit nicht ausdrücklich zugestanden. Zuwiderhandlungen verpflichten zu Schadensersatz. Alle Rechte vorbehalten, insbesondere für den Fall der Patenterteilung oder GM-Enttragung.

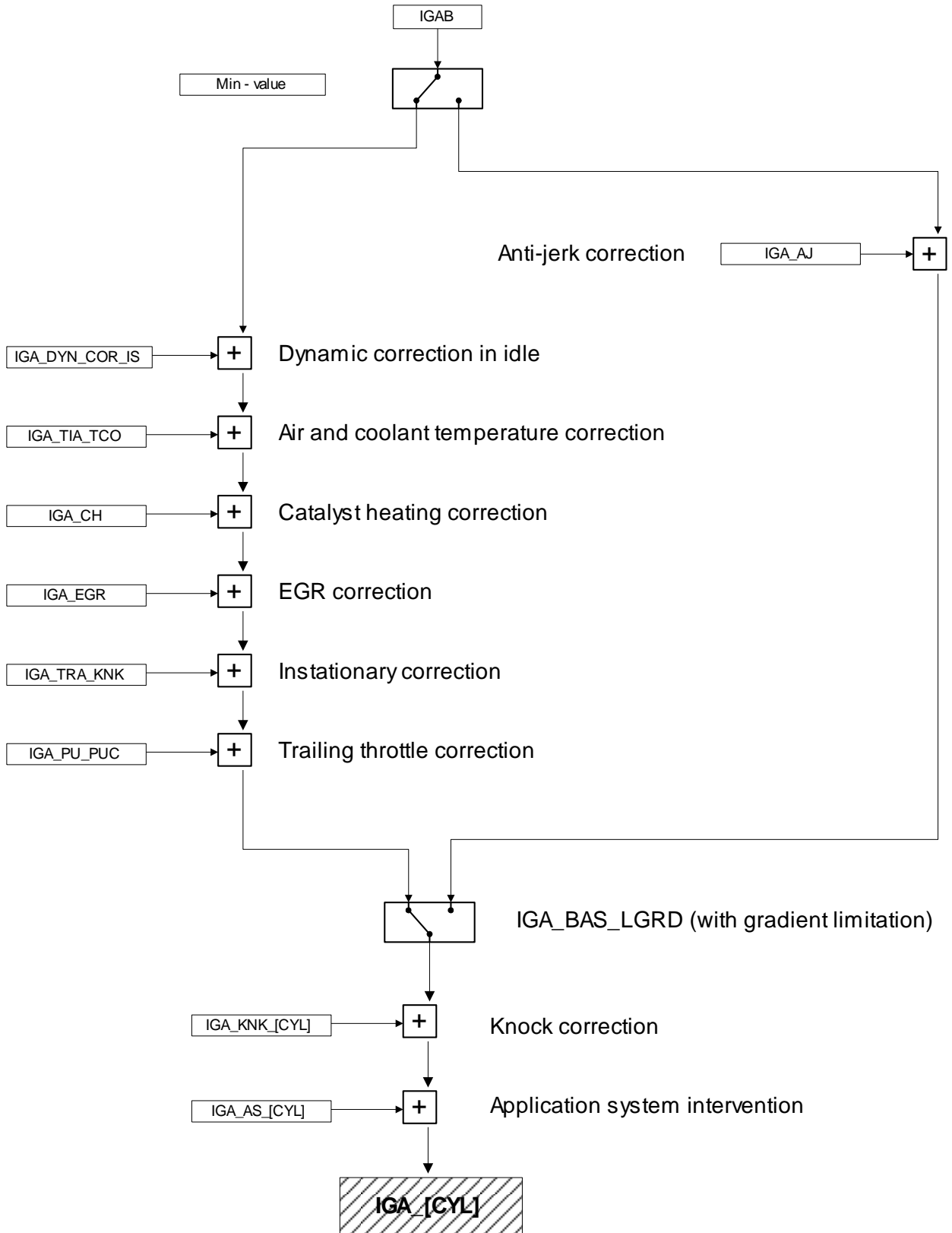

Editor: Müller O.	17-Dec-97	Ignition	HMC_V6
Version: a 153589 from 18.12.97		657765.49.05	
File: CHAP_6.DOC	650H0000	Sourcefile:07600101.00C	Page 13 / 53

1.1.1.2 Ignition angle application (IGA_IGC_[CYL], IGA_IGC_SAM)

General information:

The algorithm for torque intervention (GS, ASR or MSR) uses ignition angle control. It provides IGA_IGC_[CYL] with IGA_CYL_[CYL] from applicative layer and IGA_TQR through a torque intervention model as input data.

The minimum ignition angle is limited to ID_IGA_MIN_PL__TCO in part load (LV_PL).

Description:

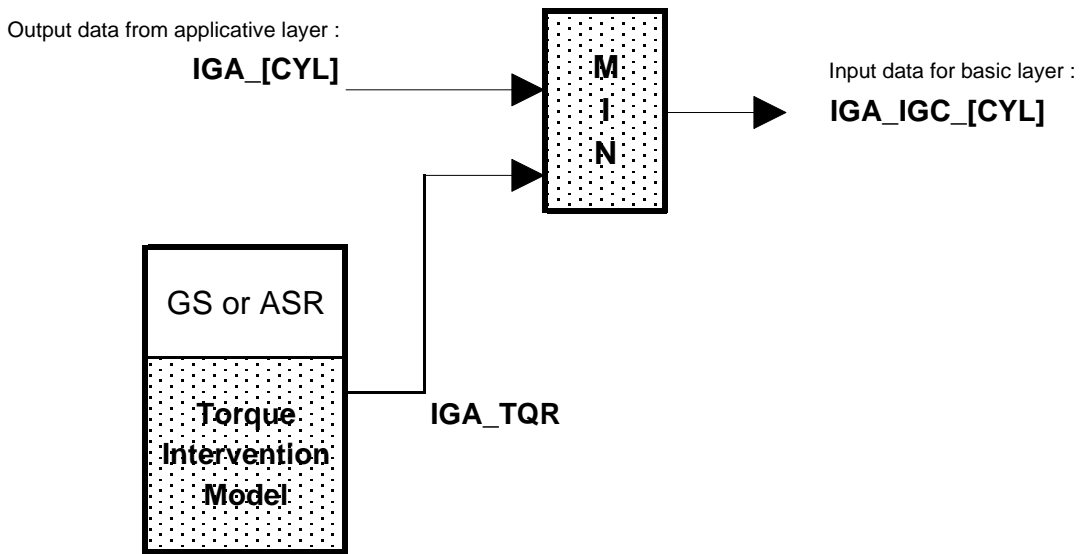

Formula section:

```

If      LV_PL = 1
then

      If    IGA_IGC_[CYL] <= ID_IGA_MIN_PL__TCO
      then  IGA_IGC_[CYL] = ID_IGA_MIN_PL__TCO
    
```

Calibration data:

Name	Dim	Hex. limits	Phys. limits	Resol.	Unit
ID_IGA_MIN_PL__TCO	8	0...FFH	72 ...-23,625	0,375	°CRK
Ignition angle limitation in retard direction in part load.					
NC_INI_IGA	1	0...FFH	72 ...-23,625	0,375	°CRK
First ignition angle following synchronisation in engine stopped (LV_ES) - Non adjustable calibration.					

Applicative Value :

NC_INI_IGA = 50H = 6,375 °CRK

Editor: Müller O.	17-Dec-97	Ignition	HMC_V6
Version: a 153589 from 18.12.97		657765.49.05	
File: CHAP_6.DOC	650H0000	Sourcefile:07600101.00C	Page 14 / 53

Proprietary data, company confidential. All rights reserved. Contine a titre de secret d'entreprise. Tous droits réservés. Comunicado como segredo empresarial. Reservados todos os direitos. Confidado como secreto industrial. Nos reservamos todos los derechos.

Weitergabe sowie Vervielfältigung dieser Unterlage, Verwertung und Mitteilung ihres Inhalts nicht gestattet, soweit nicht ausdrücklich zugestanden. Zuwiderhandlungen verpflichten zu Schadenersatz. Alle Rechte vorbehalten, insbesondere für den Fall der Patenterteilung oder GM-Entragung.

1.2 Calculation of ignition angle corrections

1.2.1 Dynamic ignition angle correction in idle (IGA_DYN_COR_IS)

Output data:

Name	Mode	Hex. limits	Phys. limits	Resol.	Unit
IGA_DYN_COR_IS	V	0...FFH	-48...47,625	0,375	°CRK
Dynamic ignition angle correction in idle (LV_IS).					

Input data:

LV_IS	LV_ST	LV_IGA_AST	LV_ISAPWM_IS_ACT
N_DIF_COR	TCO	VS	

FUNCTION DESCRIPTION:

General information:

This ignition angle intervention is depending on the engine speed deviation from the nominal idle speed.

The calculation is made depending on the state of the idle speed regulation. As soon as the regulation is active, the dynamic ignition angle correction is applied with a factor which depends on VS and N_DIF_COR. It also prevents excessive overshooting when a transition from start (LV_ST) to idle (LV_IS) appeared with engine speed above nominal idle speed.

Application recurrence : **Segment**

Formula section:

```

- If      engine operating state idle (LV_IS) active
  and    LV_ISAPWM_IS_ACT = 1 (Active)    (idle speed regulation active)
then
  If      ( VS = 0 or N_DIF_COR > 0 )
  then
    IGA_DYN_COR_IS = IP_IGA_N_DIF_IS(AT)__N_DIF_COR * IP_IGA_FAC_IS(AT)__TCO
  else
    IGA_DYN_COR_IS = IP_IGA_N_DIF_IS__N_DIF_COR * IP_IGA_FAC_IS(AT)__TCO
                  * C_IGA_N_DIF_FAC_IS
else
  If      engine operating state idle (LV_IS) active
  and    LV_IGA_AST = 1 (Active)    (ignition angle intervention due to post
                                     start function)
  then
    IGA_DYN_COR_IS = IP_IGA_AST__N_DIF_COR
  else
    IGA_DYN_COR_IS = 0
Endif.

```

Editor: Müller O.	17-Dec-97	Ignition	HMC_V6
Version: a 153589 from 18.12.97		657765.49.05	
File: CHAP_6.DOC	650H0000	Sourcefile:07600501.00B	Page 15 / 53

Calibration data:

Name	Dim	Hex. limits	Phys. limits	Resol.	Unit
IP_IGA_AST__N_DIF_COR	4	0...FFH	-48...47,625	0,375	°CRK
Dynamic ignition angle correction for post start function (LV_IGA_AST).					
IP_IGA_N_DIF_IS(_AT)__N_DIF_COR	12	0...FFH	-48...47,625	0,375	°CRK
Dynamic ignition angle correction for idle speed stabilisation (LV_ISAPWM_IS_ACT).					
IP_IGA_FAC_IS(_AT)__TCO	4	0...FFH	0...0,996	1 / 256	-
Weighting factor versus coolant temperature for dynamic ignition angle correction.					
C_IGA_N_DIF_FAC_IS	1	0...FFH	0...0,996	1/256	-
Dynamic angle correction in case of vehicle running					

Proprietary data, company confidential. All rights reserved.
 Contie a titre de secret d'entreprise. Tous droits réservés.
 Comunicado como segredo empresarial. Reservados todos os direitos.
 Confidado como secreto industrial. Nos reservamos todos los derechos.

Weitergabe sowie Vervielfältigung dieser Unterlage, Verwertung und Mitteilung ihres Inhalts nicht gestattet, soweit nicht ausdrücklich zugestanden. Zuwiderhandlungen verpflichten zu Schadensersatz. Alle Rechte vorbehalten, insbesondere für den Fall der Patenterteilung oder GM-Eintragung

Editor: Müller O.	17-Dec-97	Ignition	HMC_V6
Version: a 153589 from 18.12.97		657765.49.05	
File: CHAP_6.DOC	650H0000	Sourcefile:07600501.00B	Page 16 / 53

1.2.2 Air and coolant temperatures correction out of idle (IGA_TIA_TCO)

Output data:

Name	Mode	Hex. limits	Phys. limits	Resol.	Unit
IGA_TIA_TCO	V	0...FFH	-48...47,625	0,375	°CRK
Ignition angle correction versus temperatures out of idle.					

Input data:

TIA	TCO	N_32	MAF
-----	-----	------	-----

FUNCTION DESCRIPTION:

General information:

The basic ignition angle out of idle is adjusted versus ambient conditions.

It is increased for low coolant temperature and decreased for high air temperature when engine is warm.

Application recurrence : **720 °CRK**

Formula section:

$IGA_TIA_TCO = IP_TIA_TCO_FAC(_AT)_TIA_TCO * IP_IGA_N_MAF_N_32_MAF$

Calibration data:

Name	Dim	Hex. limits	Phys. limits	Resol.	Unit
IP_TIA_TCO_FAC(_AT)_TIA_TCO	6 x 6	00...FFH	-1...0,992	7,8125E-3	-
Weighting factor versus temperatures for ignition angle correction IGA_TIA_TCO.					
IP_IGA_N_MAF_N_32_MAF	8 x 6	0...FFH	-48...47,625	0,375	°CRK
Basic ignition angle correction versus temperatures out of idle.					

Proprietary data, company confidential. All rights reserved. Contient des informations confidentielles de Siemens. Tous droits réservés. Comunicado como segredo empresarial. Reservados todos os direitos. Confidado como secreto industrial. Nos reservamos todos los derechos.

Weitergabe sowie Vervielfältigung dieser Unterlage, Verwertung und Mitteilung ihres Inhalts ist gestattet, soweit nicht ausdrücklich zugestanden. Zuwiderhandlungen verpflichten zu Schadensersatz. Alle Rechte vorbehalten, insbesondere für den Fall der Patenterteilung oder GM-Entragung.

1.2.3 Catalyst heating correction (IGA_CH)

Output data:

Name	Mode	Hex. limits	Phys. limits	Resol.	Unit
IGA_CH	V	0...FFH	-48...47,625	0,375	°CRK
Catalyst heating ignition angle correction.					

Input data:

LV_IGA_CH	LV_IS	N_32	MAF
TCO	T_AST	LV_TPS_FL	ID_IGA_T_CH__TCO_ST

FUNCTION DESCRIPTION:

General information:

The basic ignition angle out of start is adjusted in order to improve catalyst heating during warm-up. Thus, the catalyst reaches its service temperature quicker and earlier its own efficiency.

Application recurrence :

- segment : if LV_IGA_CH = 1 (Active). IGA_CH is performed without gradient limitation.
- 720 °CRK : if LV_IGA_CH deactivated. IGA_CH is reset with a gradient limitation.

Formula section:

If LV_IGA_CH = 1 (Active)
then
If engine operating state idle speed (LV_IS) active
then

$IGA_CH = IP_IGA_CH_IS_N_32_MAF * IP_IGA_TCO_CH_IS_TCO_T_AST$

else

$IGA_CH = IP_IGA_CH_N_32_MAF * IP_IGA_TCO_CH_TCO_T_AST$

(out of idle)

Remark :

- When the duration ID_IGA_T_CH__TCO_ST has elapsed, the catalyst heating ignition angle correction is disabled using a gradient limitation C_IGA_LGRD_CH.
- The ignition angle intervention for catalyst heating function is stopped when full load (LV_TPS_FL) is required.

Proprietary data, company confidential. All rights reserved. Contine a titre de secret d'entreprise. Tous droits réservés. Comunicado como segredo empresarial. Reservados todos os direitos. Confidado como secreto industrial. Nos reservamos todos los derechos.

Weitergabe sowie Vervielfältigung dieser Unterlage, Verwertung und Mitteilung ihres Inhalts nicht gestattet, soweit nicht ausdrücklich zugestanden. Zuwiderhandlungen verpflichten zu Schadensersatz. Alle Rechte vorbehalten, insbesondere für den Fall der Patenterteilung oder GM-Entragung.

Editor: Müller O.	17-Dec-97	Ignition	HMC_V6
Version: a 153589 from 18.12.97		657765.49.05	
File: CHAP_6.DOC	650H0000	Sourcefile:07600B01.00E	Page 18 / 53

Calibration data:

Name	Dim	Hex. limits	Phys. limits	Resol.	Unit
IP_IGA_CH_IS__N_32__MAF	8 x 8	0...FFH	-48...47,625	0,375	°CRK
Catalyst heating ignition angle correction versus engine speed in idle (LV_IS).					
IP_IGA_TCO_CH_IS__TCO__T_AST	8 x 8	0...FFH	0...0,997	3,895E-3	-
Catalyst heating ignition angle factor versus coolant temperature in idle (LV_IS).					
IP_IGA_CH__N_32__MAF	8 x 8	0...FFH	-48...47,625	0,375	°CRK
Catalyst heating ignition angle correction versus engine speed out of idle.					
IP_IGA_TCO_CH__TCO__T_AST	8 x 8	0...FFH	0...0,997	3,895E-3	-
Catalyst heating ignition angle factor versus coolant temperature out of idle.					
C_IGA_LGRD_CH	1	01H...7FFFH	0,00146...48	48 / 32767	°CRK
Gradient limitation for catalyst heating ignition angle correction disabling.					

Proprietary data, company confidential. All rights reserved.
 Contit a titre de secret d'entreprise. Tous droits réservés.
 Comunicado como segredo empresarial. Reservados todos os direitos.
 Confidado como secreto industrial. Nos reservamos todos los derechos.

Weitergabe sowie Vervielfältigung dieser Unterlage, Verwertung und Mitteilung ihres Inhalts nicht gestattet, soweit nicht ausdrücklich zugestanden. Zuwiderhandlungen verpflichten zu Schadensersatz. Alle Rechte vorbehalten, insbesondere für den Fall der Patenterteilung oder GM-Eintragung

Editor: Müller O.	17-Dec-97	Ignition	HMC_V6
Version: a 153589 from 18.12.97		657765.49.05	
File: CHAP_6.DOC	650H0000	Sourcefile:07600B01.00E	Page 19 / 53

1.2.4 Instationary correction (IGA_TRA_KNK)

Output data:

Name	Mode	Hex. limits	Phys. limits	Resol.	Unit
IGA_TRA_KNK	V	0...80H	-48...0	0,375	°CRK
Ignition angle for instationary correction.					
LV_TRA_KNK_ACT	V	0...01H	0...1	1	-
Boolean information for ignition instationary correction requested - (Passive / Active).					

Input data:

LV_PL	N_32	MAF	TIA
LV_PUC	TCO	TPS_GRD	C_TPS_GRD_BOL_RPL
LV_REAC	ID_IGA_RPL__N_32__TCO		

FUNCTION DESCRIPTION:

General information:

In order to prevent knock during strong acceleration, an ignition angle correction is applied to the nominal ignition angle out of start.

Application recurrence : **Segment.**

Application conditions:

- Preliminary :

If LV_PUC → LV_PL (restart fuel feed at part load - LV_REAC = 0 → 1)
and TPS_GRD < C_TPS_GRD_BOL_RPL (smooth acceleration)
and IGA_TRA_KNK < ID_IGA_RPL__N_32__TCO
or
and engine operating state part load (LV_PL) active
and TPS_GRD ≥ ID_IGA_TPS_GRD_TRA__N_32 (strong acceleration)
then LV_TRA_KNK_ACT = 1 (Active)
else LV_TRA_KNK_ACT = 0 (Passive)
Endif.

Formula section:

If LV_TRA_KNK_ACT = 1 (Active)
then

$$IGA_TRA_KNK = ID_IGA_TRA_KNK(_AT)_N_32_MAF * IP_IGA_TRA_FAC(_AT)_TIA$$

and as soon as $IGA_TRA_KNK_n \geq IGA_TRA_KNK_{n-1}$,
 IGA_TRA_KNK remains unmodified during
 ID_IGA_CYCNR_TRA_KNK__N_32__MAF x segments.

else IGA_TRA_KNK = 0.

Editor: Müller O.	17-Dec-97	Ignition	HMC_V6
Version: a 153589 from 18.12.97		657765.49.05	
File: CHAP_6.DOC	650H0000	Sourcefile:07600C01.00C	Page 20 / 53

Proprietary data, company confidential. All rights reserved.
 Contient des données confidentielles de la société. Tous droits réservés.
 Comunicado como segredo empresarial. Reservados todos os direitos.
 Confidado como secreto industrial. Nos reservamos todos los derechos.

Weitergabe sowie Vervielfältigung dieser Unterlage, Verwertung und Mitteilung ihres Inhalts ist gestattet, soweit nicht ausdrücklich zugestanden. Zuwiderhandlungen verpflichten zu Schadensersatz. Alle Rechte vorbehalten, insbesondere für den Fall der Patenterteilung oder GM-Entragung.

Description:

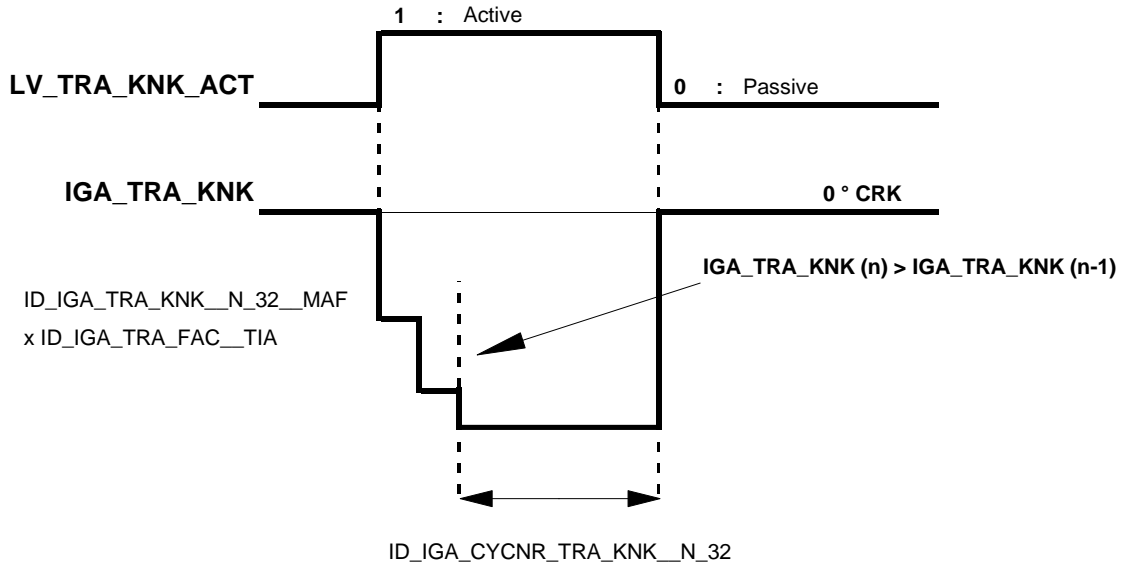

Calibration data:

Name	Dim	Hex. limits	Phys. limits	Resol.	Unit
ID_IGA_TPS_GRD_TRA__N_32	4	0...FFH	0...2988	2988 / 256	°TPS/sec
TPS_GRD threshold for ignition angle with instationary correction detection.					
ID_IGA_TRA_KNK(_AT)__N_32__MAF	4 x 4	0...80H	-48...0	0,375	°CRK
Ignition angle for instationary correction versus engine operating point.					
IP_IGA_TRA_FAC(_AT)__TIA	4	0...FFH	0...0,996	1 / 256	-
Weighting factor versus air temperature for ignition angle during instationary correction.					
ID_IGA_CYCNR_TRA_KNK(_AT)__N_32	4	0...FFH	0...255	1	-
Duration of ignition angle during instationary correction - (x Segment).					

Proprietary data, company confidential. All rights reserved.
 Contine a titre de secret d'entreprise. Tous droits réservés.
 Comunicado como segredo empresarial. Reservados todos os direitos.
 Confidado como secreto industrial. Nos reservamos todos los derechos.

Weitergabe sowie Vervielfältigung dieser Unterlage, Verwertung und Mitteilung ihres Inhalts nicht gestattet, soweit nicht ausdrücklich zugestanden. Zuwiderhandlungen verpflichten zu Schadenersatz. Alle Rechte vorbehalten, insbesondere für den Fall der Patenterteilung oder GM-Enttragung.

Editor: Müller O.	17-Dec-97	Ignition	HMC_V6
Version: a 153589 from 18.12.97		657765.49.05	
File: CHAP_6.DOC	650H0000	Sourcefile:07600C01.00C	Page 21 / 53

1.2.5 Anti - jerk correction (IGA_AJ)

Output data:

Name	Mode	Hex. limits	Phys. limits	Resol.	Unit
IGA_AJ	V	80H...7FH	-48...47,625	0,375	°CRK
Anti - jerk ignition angle correction.					
T_MES_GRD_AJ	V	8000...7FFFH	-0,125...0,125	3,814E-5	-
Segment time ratio for activation conditions of the anti - jerk function.					
SUM_TRIG_AJ	V	0...0AH	0...10	1	-
Triggering counter for successive ignition angle intervention.					
LV_TRA_TPS_GRD_MIN_AJ	V	0...01H	0...1	1	-
Boolean corresponding to TPS gradient conditions for activation of the anti - jerk function (passive / active).					
LV_AJ_ACT	V	0...01H	0...1	1	-
Boolean for ignition angle intervention when anti - jerk function is required (passive / active).					

Input data:

N_32	TPS_GRD	T_SEG	VS
N	LV_DRI	LV_PL	LV_IV_[CYL]_ERR
MAF	LV_STATE_A_MIS	LV_DUR_IGC_[CYL]_ERR	LV_CRK_ERR
TCO	LV_STATE_B_MIS	ID_IGA_LGRD_END_AJ_N_32	LV_CAM_ERR

FUNCTION DESCRIPTION:

General information:

Due to sudden transition from an engine operating point in low part load to wide open throttle, jerking can occur in the lower engine speed range during acceleration.

These jerks have to be suppressed, which can be achieved by a selective torque reduction. Thus ignition is retarded during the positive half - wave of the engine speed wave.

1 - Segment time ratio T_MES_GRD_AJ :

In order to start ignition intervention, "jerk" must be previously detected using the segment time ratio T_MES_GRD_AJ.

It is calculated using the corresponding segment periods :

$$T_REV_ACT = (T_SEG_n + T_SEG_{n-1})$$

$$T_REV_LAST = (T_SEG_{n-2} + T_SEG_{n-3})$$

if $N_32 \leq C_N_THD_T_MES_AJ$

then $T_MES_GRD_AJ = (T_SEG_n - T_SEG_{n-1}) / T_SEG_n$

else $T_MES_GRD_AJ = (T_REV_ACT - T_REV_LAST) / T_REV_ACT$

Editor: Müller O.	17-Dec-97	Ignition	HMC_V6
Version: a 153589 from 18.12.97		657765.49.05	
File: CHAP_6.DOC	650H0000	Sourcefile:07600D01.00E	Page 22 / 53

Proprietary data, company confidential. All rights reserved.
 Contine a titre de secret d'entreprise. Tous droits réservés.
 Comunicado como segredo empresarial. Reservados todos os direitos.
 Confidado como secreto industrial. Nos reservamos todos los derechos.

Weitergabe sowie Veröffentlichung dieser Unterlage, Verwertung und Mitteilung ihres Inhalts nicht gestattet, soweit nicht ausdrücklich zugestanden. Zuwiderhandlungen verpflichten zu Schadenersatz. Alle Rechte vorbehalten, insbesondere für den Fall der Patenterteilung oder GM-Entragung.

2 - TPS gradient condition LV_TRA_TPS_GRD_MIN_AJ :

In order to start ignition intervention for first triggering, a condition on the gradient of the throttle position sensor must be provided.

It is defined using the following algorithm :

```

if          TPS_GRD > C_TPS_GRD_MIN_AJ          ( LV_DRI = - )
or          TPS_GRD > C_DRI_TPS_GRD_MIN_AJ      ( LV_DRI = DRI )
then        LV_TRA_TPS_GRD_MIN_AJ = 1 (Active)
and         C_T_TPS_GRD_MIN_AJ is started.

if          C_T_TPS_GRD_MIN_AJ has elapsed
or          anti - jerk deactivation conditions are fulfilled
then        LV_TRA_TPS_GRD_MIN_AJ = 0 (Passive)
  
```

Application conditions:

1 - Anti - jerk function :

Activation :

```

Engine operating state part load (LV_PL)
and TCO > C_TCO_MIN_AJ
and C_N_MIN_AJ < N_32 < C_N_MAX_AJ
and C_VS_MIN_AJ < VS < C_VS_MAX_AJ
and the following diagnosis errors are not permitted :
      LV_CRK_ERR = 0          (crankshaft sensor)
and LV_CAM_ERR = 0          (camshaft sensor)
and LV_DUR_IGC_[CYL]_ERR = 0 (ignition coils)
and LV_IV_[CYL]_ERR = 0     (injector valves)
and LV_STATE_A_MIS = 0     (misfire status - error CARB A)
and LV_STATE_B_MIS = 0     (misfire status - error CARB B)
  
```

Deactivation :

```

T_MES_GRD_AJ > IP_T_MES_GRD_END_AJ__N_32
or timer C_T_MAX_AJ has elapsed
or timer C_T_MAX_GRD_2_ST_AJ has elapsed.
  
```

Editor: Müller O.	17-Dec-97	Ignition	HMC_V6
Version: a 153589 from 18.12.97		657765.49.05	
File: CHAP_6.DOC	650H0000	Sourcefile:07600D01.00E	Page 23 / 53

2 - Ignition intervention - First triggering :

Activation :

```

if          LV_TRA_TPS_GRD_MIN_AJ = 1 (active)
              and    T_MES_GRD_AJ < IP_T_MES_GRD_1_ST_AJ__N_32
              and    T_MES_GRD_AJ ≤ IP_T_MES_GRD_END_AJ__N_32
then
              SUM_TRIG_AJ = 1          (initialisation)
              and    LV_AJ_ACT = 1 (active)      (ignition angle intervention takes
                                                    place)
              and    C_T_MAX_GRD_2_ST_AJ      (timer initialisation)
              and    C_T_MAX_AJ                (timer initialisation)
    
```

Remark : C_T_MAX_AJ < C_T_MAX_GRD_2_ST_AJ

3 - Ignition intervention - Second triggering and further :

Activation :

```

if          1 < SUM_TRIG_AJ ≤ C_SUM_TRIG_AJ
              and    T_MES_GRD_AJ < IP_T_MES_GRD_2_ST_AJ__N_32
              and    T_MES_GRD_AJ ≤ IP_T_MES_GRD_END_AJ__N_32
then
              LV_AJ_ACT = 1 (Active)(ignition angle intervention take place)
              and    SUM_TRIG_AJi = SUM_TRIG_AJi-1 + 1
              and    C_T_MAX_AJ initialisation.
    
```

Formula section:

First triggering :

```

if          LV_AJ_ACT = 1 (Active)
              and    SUM_TRIG_AJ = 1
then        IGA_AJ = IP_IGA_AJ__N_32__MAF
    
```

Second triggering :

```

if          LV_AJ_ACT = 1 (Active)
              and    SUM_TRIG_AJ = 2
then        IGA_AJ = IP_IGA_AJ__N_32__MAF * C_IGA_FAC_2_AJ
    
```

Third and further triggering :

```

if          LV_AJ_ACT = 1 (Active)
              and    2 < SUM_TRIG_AJ ≤ C_SUM_TRIG_AJ
then        IGA_AJ = IP_IGA_AJ__N_32__MAF * C_IGA_FAC_3_AJ
    
```

Editor: Müller O.	17-Dec-97	Ignition	HMC_V6
Version: a 153589 from 18.12.97		657765.49.05	
File: CHAP_6.DOC	650H0000	Sourcefile:07600D01.00E	Page 24 / 53

Proprietary data, company confidential. All rights reserved. Contine a titre de secret d'entreprise. Tous droits réservés. Comunicado como secreto empresarial. Reservados todos os direitos. Confidado como secreto industrial. Nos reservamos todos los derechos.

Weitergabe sowie Vervielfältigung dieser Unterlage, Verwertung und Mitteilung ihres Inhalts nicht gestattet, soweit nicht ausdrücklich zugestanden. Zuwiderhandlungen verpflichten zu Schadensersatz. Alle Rechte vorbehalten, insbesondere für den Fall der Patenterteilung oder GM-Eintragung.

Remark :

The ignition angle retard adjustment is applied with a gradient limitation ID_IGA_LGRD_ST_AJ_N_32. The return to the nominal ignition angle at the end of the correction is performed with a gradient limitation ID_IGA_LGRD_END_AJ_N_32 (refer to the chapter " Ignition angle gradient limitation ")

Description:

1 - Ignition intervention description :

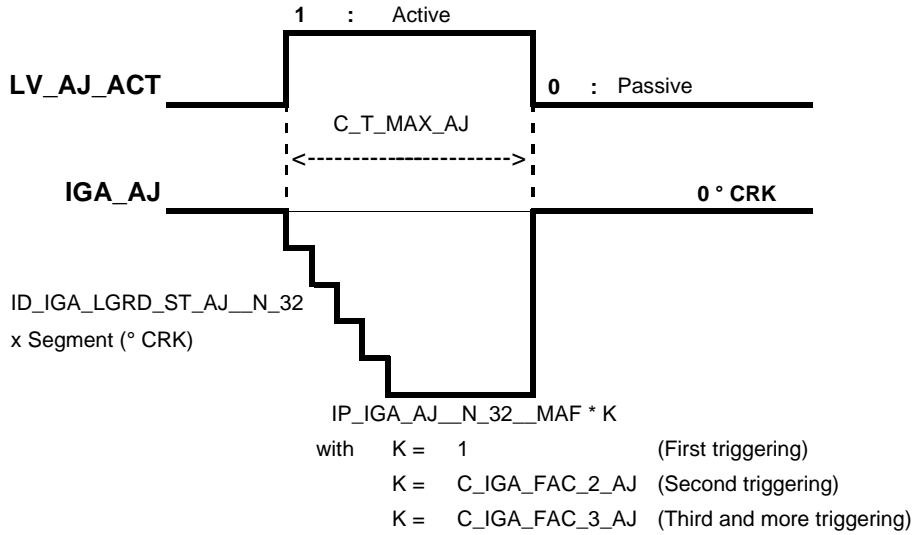

2 - Timer description :

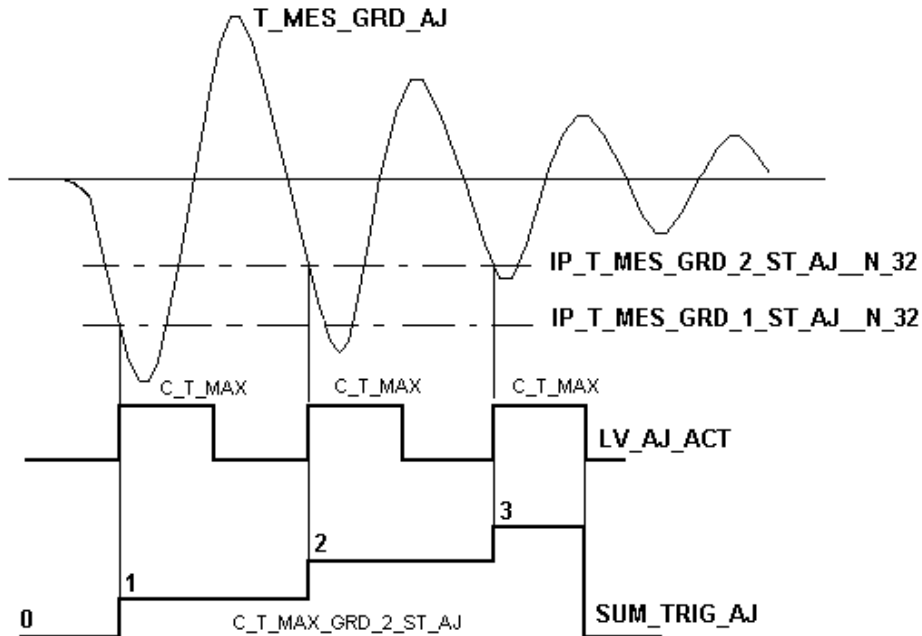

Editor: Müller O.	17-Dec-97	Ignition	HMC_V6
Version: a 153589 from 18.12.97		657765.49.05	
File: CHAP_6.DOC	650H0000	Sourcefile:07600D01.00E	Page 25 / 53

Calibration data:

Name	Dim	Hex. limits	Phys. limits	Resol.	Unit
IP_IGA_AJ_N_32_MAF	8 x 6	0...80H	-48...0	0,375	°CRK
Basic anti-jerk ignition angle correction.					
ID_IGA_LGRD_ST_AJ_N_32	8	01...FFH	0,375...95,625	0,375	°CRK
Gradient limitation to reach the anti-jerk ignition angle correction (x Segment).					
IP_T_MES_GRD_1_ST_AJ_N_32	10	0...8000H	-0,125...0	3,8E-6	msec/mse
T_MES_GRD_AJ threshold for first ignition intervention triggering.					
IP_T_MES_GRD_2_ST_AJ_N_32	10	0...8000H	-0,125...0	3,8E-6	msec/mse
T_MES_GRD_AJ threshold for second and further ignition intervention triggering.					
IP_T_MES_GRD_END_AJ_N_32	10	0...8000H	-0,125...0	3,8E-6	msec/mse
T_MES_GRD_AJ threshold to cancel anti-jerk ignition angle correction.					
C_N_THD_T_MES_AJ	1	0...FFH	0...8160	32	rpm
Engine speed threshold for calculation of T_MES_GRD_AJ.					
C_TCO_MIN_AJ	1	0...FEH	-48...142,5	0,75	°C
Minimum coolant temperature threshold for application condition of anti-jerk function.					
C_N_MIN_AJ	1	0...FFH	0...8160	32	rpm
Minimum engine speed threshold for application condition of anti-jerk function.					
C_N_MAX_AJ	1	0...FFH	0...8160	32	rpm
Maximum engine speed threshold for application condition of anti-jerk function.					
C_VS_MIN_AJ	1	0...FFH	0...255	1	km/h
Minimum vehicle speed threshold for application condition of anti-jerk function.					
C_VS_MAX_AJ	1	0...FFH	0...255	1	km/h
Maximum vehicle speed threshold for application condition of anti-jerk function.					
C_TPS_GRD_MIN_AJ	1	0...FFH	0...2988	11,72	°TPS/sec
Minimum TPS_GRD threshold for application condition of anti-jerk function. (DRIVE not engaged).					
C_DRI_TPS_GRD_MIN_AJ	1	0...FFH	0...2988	11,72	°TPS/sec
Minimum TPS_GRD threshold for application condition of anti-jerk function. (DRIVE engaged).					
C_IGA_FAC_2_AJ	1	00...FFH	0...1,000	3,906E-3	-
Weighting factor for second ignition intervention triggering.					
C_IGA_FAC_3_AJ	1	00...FFH	0...1,000	3,906E-3	-
Weighting factor for third and further ignition intervention triggering.					
C_T_MAX_AJ	1	01...FFH	0,01...25,5	0,01	sec
Maximum duration of the ignition intervention.					
C_T_MAX_GRD_2_ST_AJ	1	01...FFFFH	0,01...655,35	0,01	sec
Maximum duration of the anti-jerk function.					
C_T_TPS_GRD_MIN_AJ	1	01...FFH	0,1...25,5	0,1	sec
Time exceeding the TPS_GRD threshold for activation and deactivation of the anti-jerk function.					
C_SUM_TRIG_AJ	1	01...0AH	1...10	1	-
Number of anti-jerk ignition angle intervention triggering.					

Proprietary data, company confidential. All rights reserved.
 Contient des données confidentielles de la société. Tous droits réservés.
 Comunicado como secreto empresarial. Reservados todos los derechos.
 Confidado como secreto industrial. Nos reservamos todos los derechos.

Weitergabe sowie Vervielfältigung dieser Unterlage, Verbreitung und Mitteilung ihres Inhalts nicht gestattet, soweit nicht ausdrücklich zugestanden. Zuwiderhandlungen verpflichten zu Schadenersatz. Alle Rechte vorbehalten, insbesondere für den Fall der Patenterteilung oder GM-Entragung.

Editor: Müller O.	17-Dec-97	Ignition	HMC_V6
Version: a 153589 from 18.12.97		657765.49.05	
File: CHAP_6.DOC	650H0000	Sourcefile:07600D01.00E	Page 26 / 53

1.2.6 Trailing throttle correction (IGA_PU_PUC)

Output data:

Name	Mode	Hex. limits	Phys. limits	Resol.	Unit
IGA_PU_PUC	V	0...80H	-48...0	0,375	°CRK
Trailing throttle ignition angle correction.					

Input data:

LV_PL	LV_PU	LV_PU_PUC_TRA_FAST	LV_PUC
LV_CT	C_IGA_LGRD_x	LV_RLY_ACCOUT	TCO
MAF_MMV	N_GRD	ISAPWM_D_IS	ISAPWM_DHP
N_32	N	IP_N_MIN_PUC(_AT)_TCO	C_N_MAX_INF
IP_N_ACCIN_MIN_PUC(_AT)_TCO	C_N_GRD_MIN		

FUNCTION DESCRIPTION:

General information:

A preliminary check is made on the type of deceleration (LV_PU_PUC_TRA_FAST) at the transition from engine operating state in part load (LV_PL) to trailing throttle (LV_PU) in order to define the right ignition angle correction.

- In case of fast deceleration (LV_PU_PUC_TRA_FAST = 1 (Active)), the fuel injection is switched off immediately and the nominal ignition angle out of start is adjusted with IGA_PU_PUC in order to get the lowest possible engine torque to avoid a torque jump.

- In case of slow deceleration (LV_PU_PUC_TRA_FAST = 0 (Passive)), trailing throttle fuel cut-off is delayed and the nominal ignition angle correction out of start is adjusted with IGA_PU_PUC in order to prevent engine acceleration when shifting below high load.

Application recurrence : **Segment.**

Editor: Müller O.	17-Dec-97	Ignition	HMC_V6
Version: a 153589 from 18.12.97		657765.49.05	
File: CHAP_6.DOC	650H0000	Sourcefile:07600F01.00D	Page 27 / 53

Formula section:

- IGA_PU_PUC formula:

```

If LV_PU = 0
    and LV_PUC = 0
then
    IGA_PU_PUC = 0
else
    if LV_PUC = 1
    then
        if LV_PU_PUC_TRA_FAST = 1
        then
            IGA_PU_PUC = IP_IGA_MAX_PUC__N
        else
            IGA_PU_PUC = IP_IGA_PUC(_AT)__N or
            IP_IGA_ACCIN_PUC(_AT)__N
    else
        if LV_PU = 1
        then
            IGA_PU_PUC = IP_IGA_PU__N_TCO
            using gradient limitation in the decreasing direction
            IP_IGA_LGRD_PU(_AT)__N_32__MAF_MMV + ID_IGA_TCO_LGRD_PU__TCO
    and
    Exit conditions from LV_PU to LV_PUC are tested
    
```

Proprietary data, company confidential. All rights reserved.
 Contient des informations confidentielles de la société. Tous droits réservés.
 Comunicado como secreto empresarial. Reservados todos los derechos.
 Confidado como secreto industrial. Nos reservamos todos los derechos.

Weitergabe sowie Vervielfältigung dieser Unterlage, Verwertung und Mitteilung ihres Inhalts ist gestattet, soweit nicht ausdrücklich zugestanden. Zuwiderhandlungen verpflichten zu Schadensersatz. Alle Rechte vorbehalten, insbesondere für den Fall der Patenterteilung oder GM-Entragung.

Editor:	Müller O.	17-Dec-97	Ignition	HMC_V6
Version:	a 153589 from 18.12.97		657765.49.05	
File:	CHAP_6.DOC	650H0000	Sourcefile:07600F01.00D	Page 28 / 53

Proprietary data, company confidential. All rights reserved.
 Contient des données confidentielles. Tous droits réservés.
 Comunicado como segredo empresarial. Reservados todos os direitos.
 Confidado como secreto industrial. Nos reservamos todos los derechos.

Weitergabe sowie Vervielfältigung dieser Unterlage, Verwertung und Mitteilung ihres Inhalts nicht gestattet, soweit nicht ausdrücklich zugestanden. Zuwiderhandlungen verpflichten zu Schadensersatz. Alle Rechte vorbehalten, insbesondere für den Fall der Patenterteilung oder GM-Enttragung.

- Exit conditions from LV_PU to LV_PUC :

```

if      LV_CT = 1
and    N_32 ≥ IP_N_MIN_PUC(_AT)__TCO + Hysteresis ← (LV_RLY_ACCOUT = 0)
or    N_32 ≥ IP_N_ACCIN_MIN_PUC(_AT)__TCO + Hyst.
        ← (LV_RLY_ACCOUT = 1)
and    ISAPWM_D_IS= 0 ← (derivative term from idle speed controller inactive)
and    N_32 ≥ C_N_MAX_INF
or    ( N_32 < C_N_MAX_INF and N_GRD ≥ C_N_GRD_MIN )
then
if      LV_PU_PUC_TRA_FAST = 1 (Active) ← (fast deceleration)
then
    
```

```

LV_PUC = 1 ← (trailing throttle fuel cut-off immediately)
and    IGA_PU_PUC = IP_IGA_MAX_PUC__N ← (without gradient limitation)
    
```

```

else ← (slow deceleration)
if      N_32 < C_N_MIN_DHP
or      N_32 ≥ C_N_MIN_DHP
and    ISAPWM_DHP = 0 ← (dashpot function inactive)
and    IGA_PU_PUC = IP_IGA_PUC(_AT)__N
or    IGA_PU_PUC=IP_IGA_ACCIN_PUC(_AT)__N
        (LV_RLY_ACCOUT=1)
then
    LV_PUC = 1
else
    
```

```

LV_PU = 1
until  IGA_PU_PUC = IP_IGA_PUC(_AT)__N
or    IGA_PU_PUC = IP_IGA_ACCIN_PUC(_AT)__N ← (LV_RLY_ACCOUT = 1)

using IP_IGA_LGRD_PU(_AT)__N_32__MAF_MMV + ID_IGA_TCO_LGRD_PU__TCO
        gradient limitation
    
```

else

```

LV_PU = 1
and    IGA_PU_PUC = IP_IGA_PU__N__TCO

using IP_IGA_LGRD_PU(_AT)__N_32__MAF_MMV + ID_IGA_TCO_LGRD_PU__TCO
        gradient limitation in the decreasing direction
    
```

Editor: Müller O.	17-Dec-97	Ignition	HMC_V6
Version: a 153589 from 18.12.97		657765.49.05	
File: CHAP_6.DOC	650H0000	Sourcefile:07600F01.00D	Page 29 / 53

Description:

Proprietary data, company confidential. All rights reserved.
 Contient des données confidentielles. Tous droits réservés.
 Comunicado como secreto empresarial. Reservados todos los derechos.
 Confidado como secreto industrial. Nos reservamos todos los derechos.

Weitergabe sowie Vervielfältigung dieser Unterlage, Verwertung und Mitteilung ihres Inhalts ist gestattet, soweit nicht ausdrücklich zugestanden. Zuwiderhandlungen verpflichten zu Schadensersatz. Alle Rechte vorbehalten, insbesondere für den Fall der Patenterteilung oder GM-Entragung.

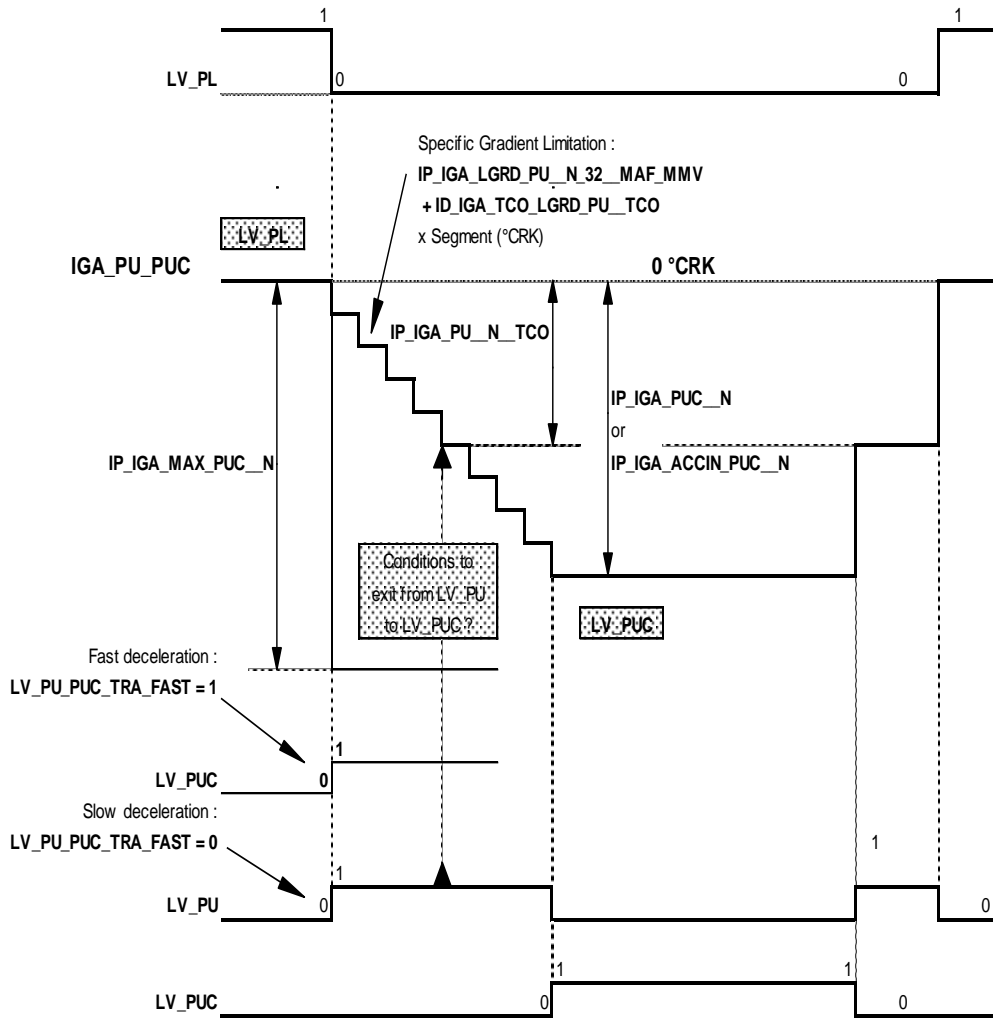

Remark :

- Tuning information :

The gradient limitation used for ignition angle correction (IGA_PU_PUC) in trailing throttle (LV_PU) or trailing throttle fuel cut-off (LV_PUC) must be lower than the general gradient limitation used for the nominal ignition angle out of start (IGA_BAS) :

$$(IP_IGA_LGRD_PU(AT)_N_32_MAF_MMV + ID_IGA_TCO_LGRD_PU_TCO) \leq C_IGA_LGRD_x$$

Editor: Müller O.	17-Dec-97	Ignition	HMC_V6
Version: a 153589 from 18.12.97		657765.49.05	
File: CHAP_6.DOC	650H0000	Sourcefile:07600F01.00D	Page 30 / 53

Calibration data:

Name	Dim	Hex. limits	Phys. limits	Resol.	Unit
IP_IGA_PU(_AT)__N__TCO	4 x 4	0...80H	-48...0	0,375	°CRK
Target ignition angle in case of slow deceleration in trailing throttle (LV_PU).					
ID_IGA_TCO_LGRD_PU(_AT)__TCO	4	01...7FFFH	0,0146...48	48 / 32767	°CRK
Gradient limitation offset versus coolant temperature for ignition angle in trailing throttle.					
IP_IGA_LGRD_PU(_AT)__N__32__MAF_MM V	4 x 4	01...7FFFH	0,0146...48	48 / 32767	°CRK
Basic gradient limitation versus engine operating point for ignition angle in trailing throttle.					
IP_IGA_MAX_PUC__N	4	0...80H	-48...0	0,375	°CRK
Target ignition angle in case of fast deceleration in trailing throttle (LV_PU).					
IP_IGA_PUC(_AT)__N	4	0...80H	-48...0	0,375	°CRK
Target ignition angle in case of trailing throttle fuel cut-off (LV_PUC).					
IP_IGA_ACCIN_PUC(_AT)__N	4	0...80H	-48...0	0,375	°CRK
Target ignition angle in case of trailing throttle fuel cut-off (LV_PUC) with air condition compressor active..					
C_N_MIN_DHP	1	0...FFH	0..8160	32	rpm
Minimum engine speed to wait for the end of the dashpot function from idle speed control to go to fuel cut-off (LV_PUC).					

Proprietary data, company confidential. All rights reserved.
 Contit a titre de secret d'entreprise. Tous droits réservés.
 Comunicado como segredo empresarial. Reservados todos os direitos.
 Confidado como secreto industrial. Nos reservamos todos los derechos.

Weitergabe sowie Vervielfältigung dieser Unterlage, Verwertung und Mitteilung ihres Inhalts nicht gestattet, soweit nicht ausdrücklich zugestanden. Zuwiderhandlungen verpflichten zu Schadensersatz. Alle Rechte vorbehalten, insbesondere für den Fall der Patenterteilung oder GM-Entragung.

Editor: Müller O.	17-Dec-97	Ignition	HMC_V6
Version: a 153589 from 18.12.97		657765.49.05	
File: CHAP_6.DOC	650H0000	Sourcefile:07600F01.00D	Page 31 / 53

1.2.7 Tuning correction (IGA_AS_[CYL])

Output data:

Name	Mode	Hex. limits	Phys. limits	Resol.	Unit
IGA_AS_[CYL]	-	80...7FH	-48...47,625	0,375	°CRK
Tuning correction for individual ignition angle.					

FUNCTION DESCRIPTION:

General information:

The application tool can perform a cylinder individual ignition angle correction using IGA_AS_[CYL] for development (e.g. knock control...).

Application recurrence : **1 sec.**

Formula section:

If IGA_AS_[CYL] not modified by serial communication line
then IGA_AS_[CYL] = C_IGA_AS_[CYL]
else IGA_AS_[CYL] controlled by serial interface until system reset.

Calibration data:

Name	Dim	Hex. limits	Phys. limits	Resol.	Unit
C_IGA_AS_[CYL]	1	80...7FH	-48...47,625	0,375	°CRK
Application system intervention for ignition angle.					

Proprietary data, company confidential. All rights reserved.
 Contient des données confidentielles de la société. Tous droits réservés.
 Comunicado como secreto empresarial. Reservados todos los derechos.
 Confidado como secreto industrial. Nos reservamos todos los derechos.

Weitergabe sowie Vervielfältigung dieser Unterlage, Verwertung und Mitteilung ihres Inhalts ist gestattet, soweit nicht ausdrücklich zugestanden. Zuwiderhandlungen verpflichten zu Schadensersatz. Alle Rechte vorbehalten, insbesondere für den Fall der Patenterteilung oder GM-Enttragung.

Editor: Müller O.	17-Dec-97	Ignition	HMC_V6
Version: a 153589 from 18.12.97		657765.49.05	
File: CHAP_6.DOC	650H0000	Sourcefile:07601101.00A	Page 32 / 53

1.3 Calculation of basic ignition angle

1.3.1 Basic ignition angle at start (IGA_ST)

Output data:

Name	Mode	Hex. limits	Phys. limits	Resol.	Unit
IGA_ST	-	0...FFH	-23,625...72	0,375	°CRK
Basic ignition angle at start (LV_ST).					

Input data:

LV_ES	LV_ST	N	TCO_ST
-------	-------	---	--------

FUNCTION DESCRIPTION:

General information:

The basic ignition angle at start (LV_ST) is depending on engine speed N, N_32 and coolant temperature TCO_ST.

It is applied following first ignition angle at engine stopped (LV_ES).

Application recurrence : **Segment**

Formula section:

$$IGA_ST = IP_IGA_ST_N_TCO_ST$$

Calibration data:

Name	Dim	Hex. limits	Phys. limits	Resol.	Unit
IP_IGA_ST_N_TCO_ST	5 x 8	0...FFH	-23,625...72	0,375	°CRK
Basic ignition angle at start (LV_ST).					

Proprietary data, company confidential. All rights reserved. Contient des informations confidentielles de Siemens. Toute réimpression ou utilisation non autorisée sans la permission écrite de la Siemens est formellement interdite.

Weitergabe sowie Vervielfältigung dieser Unterlage, Verwertung und Mitteilung ihres Inhalts ist gestattet, soweit nicht ausdrücklich zugestanden. Zuwiderhandlungen verpflichten zu Schadensersatz. Alle Rechte vorbehalten, insbesondere für den Fall der Patenterteilung oder GM-Entragung.

Editor: Müller O.	17-Dec-97	Ignition	HMC_V6
Version: a 153589 from 18.12.97		657765.49.05	
File: CHAP_6.DOC	650H0000	Sourcefile:07601901.00A	Page 33 / 53

1.3.2 Basic ignition angle out of start (IGAB)

Output data:

Name	Mode	Hex. limits	Phys. limits	Resol.	Unit
IGAB	-	0...FFH	-23,625...72	0,375	°CRK
Basic ignition angle out of start.					

Input data:

LV_IS	N	N_32	MAF
TCO			

FUNCTION DESCRIPTION:

General information:

The basic ignition angle is depending on engine operating point (N, MAF) and on engine operating states (idle (LV_IS) or out of idle).

Application recurrence : **Segment**

Formula section:

If engine operating state idle (LV_IS) active
then $IGAB = IP_IGAB_IS_N_MAF + IP_IGA_TCO_IS_TCO$
else $IGAB = IP_IGAB_N_MAF$
Endif.

Calibration data:

Name	Dim	Hex. limits	Phys. limits	Resol.	Unit
IP_IGAB__N__MAF	16 x 12	0...FFH	-23,625...72	0,375	°CRK
Basic ignition angle out of start and out of idle.					
IP_IGAB_IS__N__MAF	4 x 4	0...FFH	-23,625...72	0,375	°CRK
Basic ignition angle out of start in idle (LV_IS).					
IP_IGA_TCO_IS__TCO	6	0...FFH	-48...47,625	0,375	°CRK
Coolant temperature correction of basic ignition angle out of start in idle (LV_IS).					

Editor: Müller O.	17-Dec-97	Ignition	HMC_V6
Version: a 153589 from 18.12.97		657765.49.05	
File: CHAP_6.DOC	650H0000	Sourcefile:07601901.00A	Page 34 / 53

1.3.3 Basic ignition angle with gradient limitation (IGA_BAS_LGRD)

Output data:

Name	Mode	Hex. limits	Phys. limits	Resol.	Unit
IGA_BAS_LGRD	V	0...FFH	-23,625...72	0,375	°CRK
Basic ignition angle with gradient limitation.					

General information:

A gradient limitation is applied to the basic ignition angle calculation IGA_BAS in order to limit ignition angle variations, following the priorities described here below.

Application recurrence : **Segment**

1.3.3.1 Engine operating states without gradient limitation for ignition angle.

Input data:

LV_ISAPWM_IS_ACT	LV_ST	LV_IGA_AST	LV_PUC
IGA_BAS			

FUNCTION DESCRIPTION:

Formula section:

- If** LV_ISAPWM_IS_ACT = 1 (Active) (*idle speed regulation ISAPWM_IS active*)
or engine operating state start (LV_ST) active
or LV_IGA_AST = 1 (Active) (*ignition intervention due to post start function*)
or trailing throttle fuel cut-off (LV_PUC) active

then

$IGA_BAS_LGRD_n = IGA_BAS_n$

Endif.

Proprietary data, company confidential. All rights reserved. Contine a titre de secret d'entreprise. Tous droits réservés. Comunicado como segredo empresarial. Reservados todos os direitos. Confidado como secreto industrial. Nos reservamos todos los derechos.

Weitergabe sowie Vervielfältigung dieser Unterlage, Verbreitung und Mitteilung ihres Inhalts nicht gestattet, soweit nicht ausdrücklich zugestanden. Zuwiderhandlungen verpflichten zu Schadenersatz. Alle Rechte vorbehalten, insbesondere für den Fall der Patenterteilung oder GM-Entragung.

Editor: Müller O.	17-Dec-97	Ignition	HMC_V6
Version: a 153589 from 18.12.97		657765.49.05	
File: CHAP_6.DOC	650H0000	Sourcefile:07601401.00D	Page 35 / 53

1.3.3.2 Gradient limitation for ignition angle at intercept function (LV_INF)

Input data:

LV_INF	LV_N_GRD_INF	IGA_BAS	TCO
C_IGA_LGRD_1			

FUNCTION DESCRIPTION:

General information:

In case of an important engine speed gradient below a specific engine speed threshold and in closed throttle position, the general gradient limitation C_IGA_LGRD_1 is applied on specific ignition angle IP_IGAB_INF__TCO at intercept function.

Description:

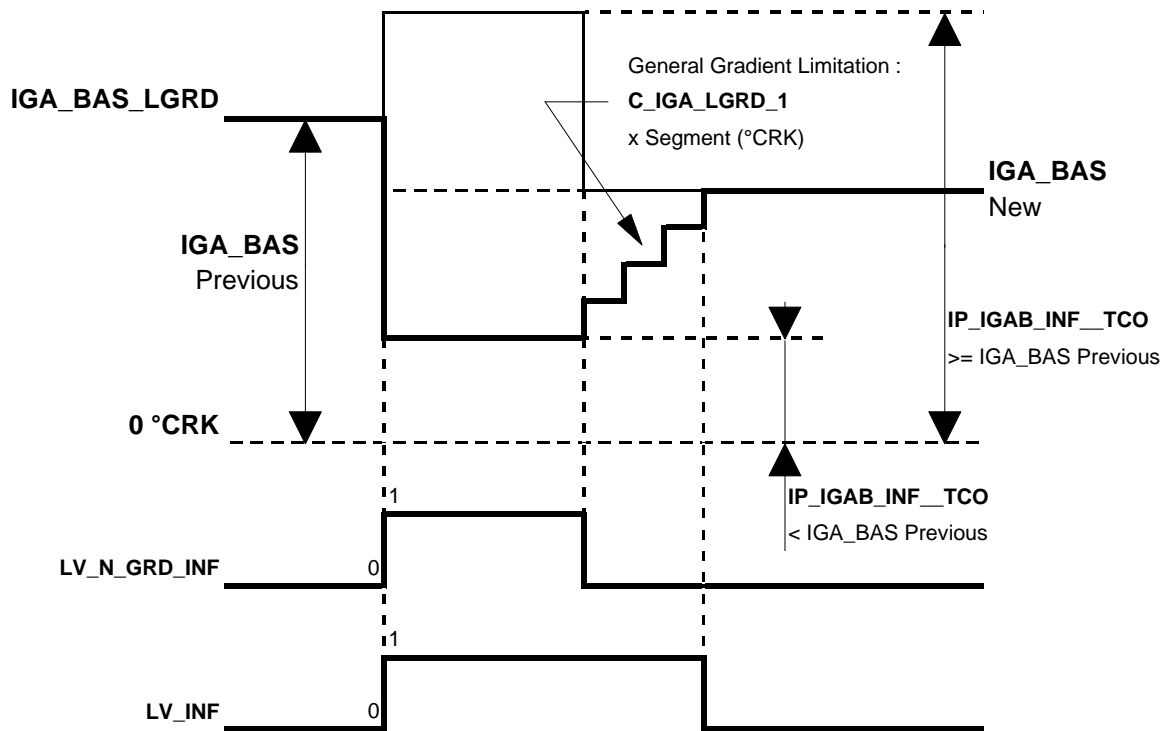

Calibration data:

Name	Dim	Hex. limits	Phys. limits	Resol.	Unit
IP_IGAB_INF__TCO	4	0...FFH	-23,625...72	0,375	°CRK
Basic ignition angle with intercept function (LV_INF) active.					

Proprietary data, company confidential. All rights reserved. Contine a titre de secret d'entreprise. Tous droits réservés. Comunicado como segredo empresarial. Reservados todos os direitos. Confidado como secreto industrial. Nos reservamos todos los derechos.

Weitergabe sowie Veröffentlichung dieser Unterlage, Verwertung und Mitteilung ihres Inhalts nicht gestattet, soweit nicht ausdrücklich zugestanden. Zuwiderhandlungen verpflichten zu Schadensersatz. Alle Rechte vorbehalten, insbesondere für den Fall der Patenterteilung oder GM-Enttragung.

1.3.3.3 Re-start fuel feed (LV_REAC) at part load (LV_PUC → LV_PL)

Input data:

LV_PUC	LV_PL	LV_REAC	IGA_BAS
N_32	TCO	TPS_GRD	IGA_TRA_KNK
C_IGA_LGRD_1	C_IGA_LGRD_2	C_IGA_LGRD_3	LV_TRA_KNK_ACT

FUNCTION DESCRIPTION:

General information:

In order to obtain a soft engine torque built - up, the ignition angle at part load (LV_PL) is retarded and reached with a gradient limitation, depending on the type of acceleration.
 The first triggering ignition angle correction for restart fuel feed at part load takes into account the instationary correction (IGA_TRA_KNK).

Description:

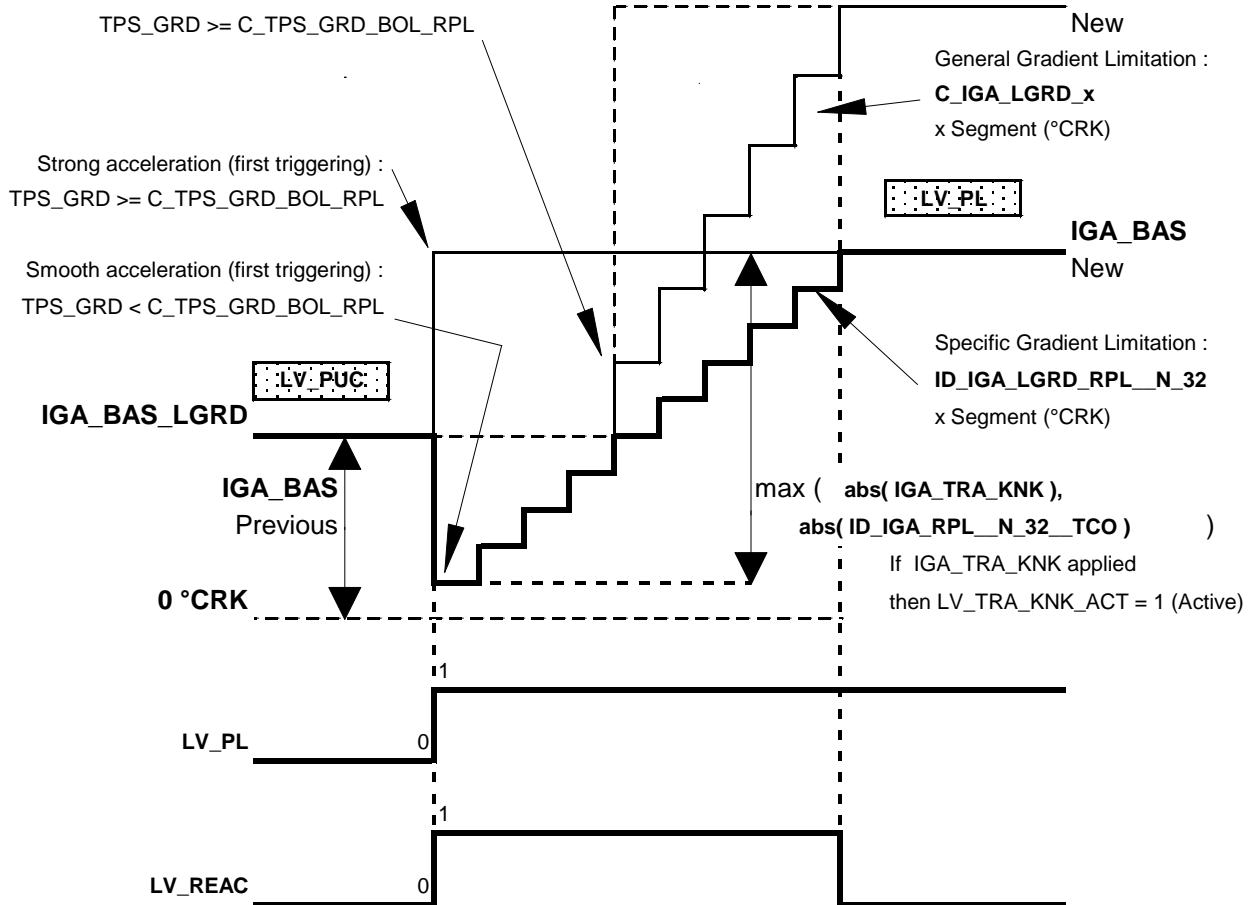

Proprietary data, company confidential. All rights reserved. Contine a titre de secret d'entreprise. Tous droits réservés. Comunicado como segredo empresarial. Reservados todos os direitos. Confidado como secreto industrial. Nos reservamos todos los derechos.

Weitergabe sowie Veröffentlichung dieser Unterlage, Verwertung und Mitteilung ihres Inhalts nicht gestattet, soweit nicht ausdrücklich zugestanden. Zuwiderhandlungen verpflichten zu Schadenersatz. Alle Rechte vorbehalten, insbesondere für den Fall der Patenterteilung oder GM-Entragung.

Editor: Müller O.	17-Dec-97	Ignition	HMC_V6
Version: a 153589 from 18.12.97		657765.49.05	
File: CHAP_6.DOC	650H0000	Sourcefile:07601401.00D	Page 37 / 53

Calibration data:

Name	Dim	Hex. limits	Phys. limits	Resol.	Unit
ID_IGA_RPL__N_32__TCO	4 x6	0...80H	-48...0	0,375	°CRK
Ignition angle correction in case of restart fuel feed at part load - First triggering.					
ID_IGA_LGRD_RPL__N_32	4	01...7FFFH	0,00146...48	48 / 32767	°CRK
Ignition angle gradient limitation for restart fuel feed at part load (x Segment).					
C_TPS_GRD_BOL_RPL	1	0...FFH	0...2988	2988 / 256	°TPS/sec
TPS_GRD threshold for strong or smooth acceleration detection in case of restart fuel feed at part load.					

Proprietary data, company confidential. All rights reserved.
 Contient des données confidentielles de la société. Tous droits réservés.
 Comunicado como secreto empresarial. Reservados todos los derechos.
 Confiado como secreto industrial. Nos reservamos todos los derechos.

Weitergabe sowie Vervielfältigung dieser Unterlage, Verwertung und Mitteilung ihres Inhalts nicht gestattet, soweit nicht ausdrücklich zugestanden. Zuwiderhandlungen verpflichten zu Schadensersatz. Alle Rechte vorbehalten, insbesondere für den Fall der Patenterteilung oder GM-Eintragung.

Editor: Müller O.	17-Dec-97	Ignition	HMC_V6
Version: a 153589 from 18.12.97		657765.49.05	
File: CHAP_6.DOC	650H0000	Sourcefile:07601401.00D	Page 38 / 53

1.3.3.4 Re-start fuel feed (LV_REAC) at idle (LV_PUC → (LV_PU)→ LV_IS)

Input data:

LV_PUC	LV_PU	LV_IS	LV_REAC
IGA_BAS	N_32	N_GRD	LV_PL
C_IGA_LGRD_1	C_IGA_LGRD_2	C_IGA_LGRD_3	LV_TRA_KNK_ACT
IGA_TRA_KNK	TPS_GRD	ID_IGA_TPS_GRD_TRA_N_32	

FUNCTION DESCRIPTION:

General information:

In order to obtain a soft engine torque built - down, the ignition angle at idle (LV_IS) is retrieved and reached with a gradient limitation, depending on the type of deceleration.

Proprietary data, company confidential. All rights reserved.
 Contient des informations confidentielles. Tous droits réservés.
 Comunicado como segredo empresarial. Reservados todos os direitos.
 Comunicado como secreto industrial. Nos reservamos todos los derechos.

Weitergabe sowie Vervielfältigung dieser Unterlage, Verwertung und Mitteilung ihres Inhalts ist gestattet, soweit nicht ausdrücklich zugestanden. Zuwiderhandlungen verpflichten zu Schadensersatz. Alle Rechte vorbehalten, insbesondere für den Fall der Patenterteilung oder GM-Eintragung.

Editor: Müller O.	17-Dec-97	Ignition	HMC_V6
Version: a 153589 from 18.12.97		657765.49.05	
File: CHAP_6.DOC	650H0000	Sourcefile:07601401.00D	Page 39 / 53

Description:

Proprietary data, company confidential. All rights reserved. Contine a titre de secret d'entreprise. Tous droits réservés. Comunicado como segredo empresarial. Reservados todos os direitos. Confidado como secreto industrial. Nos reservamos todos los derechos.

Weitergabe sowie Vervielfältigung dieser Unterlage, Verwertung und Mitteilung ihres Inhalts nicht gestattet, soweit nicht ausdrücklich zugestanden. Zuwiderhandlungen verpflichten zu Schadensersatz. Alle Rechte vorbehalten, insbesondere für den Fall der Patenterteilung oder GM-Enttragung

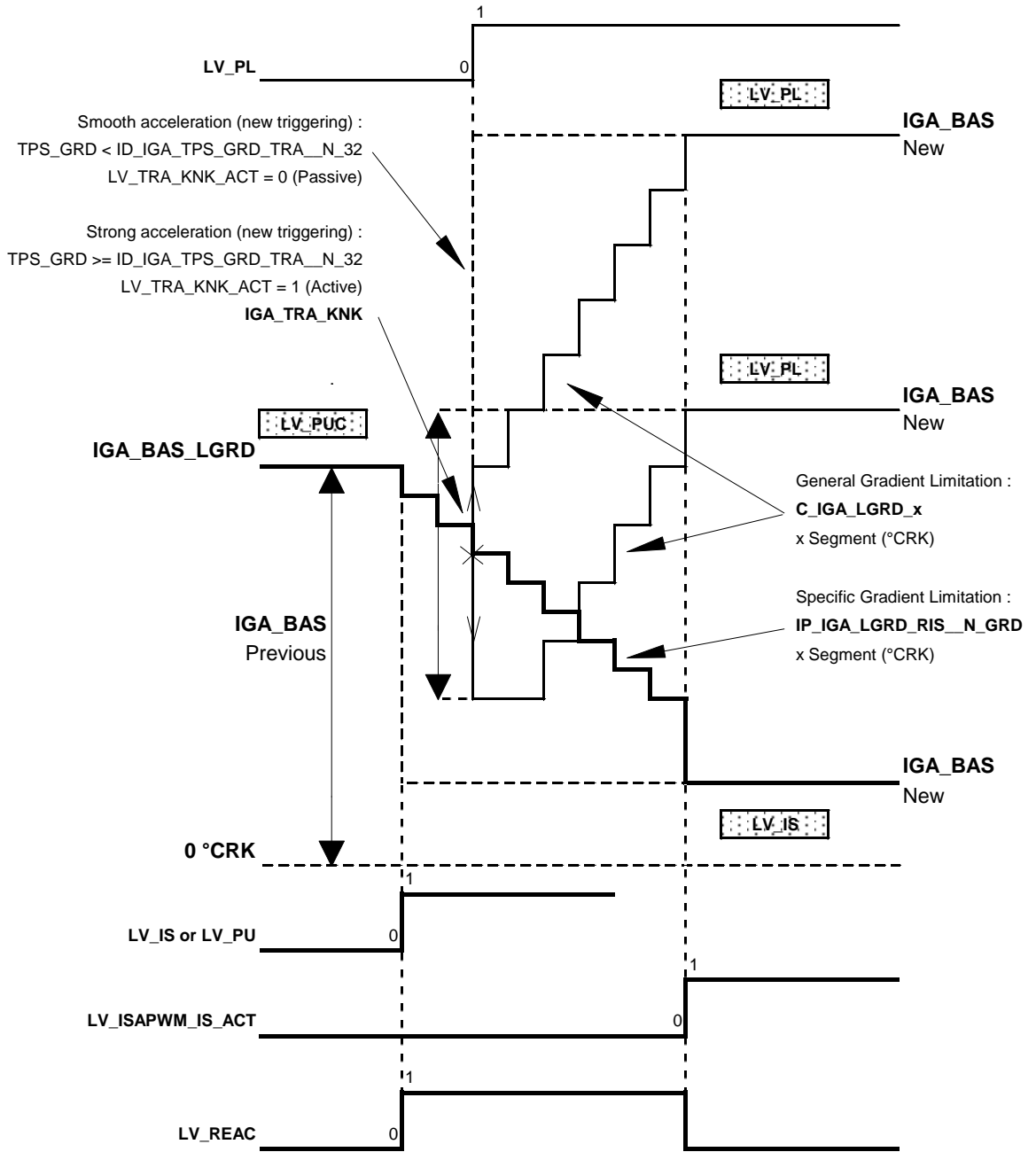

Calibration data:

Name	Dim	Hex. limits	Phys. limits	Resol.	Unit
IP_IGA_LGRD_RIS__N_GRD	4	01...7FFFH	0,00146...48	48 / 32767	°CRK
Ignition angle gradient limitation for restart fuel feed at idle (LV_IS) or trailing throttle (LV_PU) (x Segment).					

Editor: Müller O.	17-Dec-97	Ignition	HMC_V6
Version: a 153589 from 18.12.97		657765.49.05	
File: CHAP_6.DOC	650H0000	Sourcefile:07601401.00D	Page 40 / 53

1.3.3.5 Gradient limitation for ignition angle with anti-jerk correction (LV_AJ_ACT)

Input data:

LV_AJ_ACT	IGA_BAS	N_32	IGA_AJ
-----------	---------	------	--------

FUNCTION DESCRIPTION:

General information:

In order to obtain a soft engine torque built - up following anti-jerk intervention (IGA_AJ), the nominal ignition angle is reached with a gradient limitation versus engine speed.

Description:

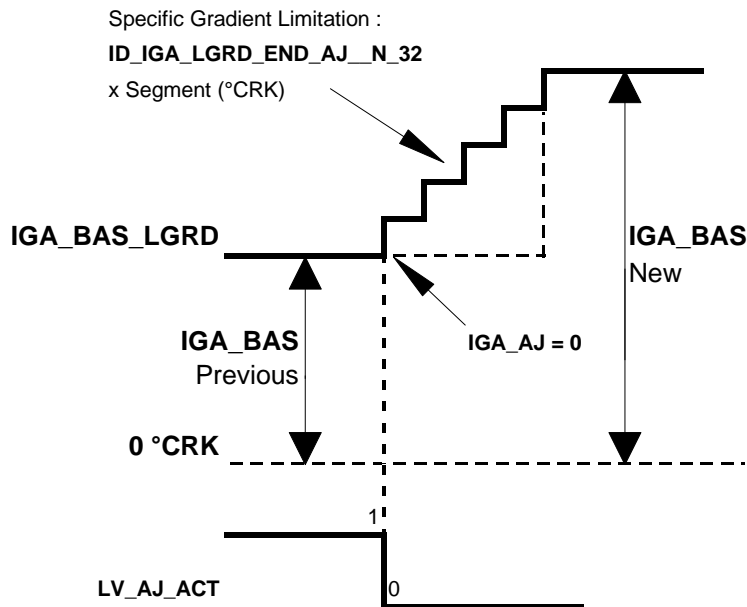

Calibration data:

Name	Dim	Hex. limits	Phys. limits	Resol.	Unit
ID_IGA_LGRD_END_AJ_N_32	8	01...FFH	0,375...95,625	0,375	°CRK
Gradient limitation to cancel the anti-jerk ignition angle correction (x Segment).					

Proprietary data, company confidential. All rights reserved.
 Contitue a titre de secret d'entreprise. Tous droits réservés.
 Comunicado como segredo empresarial. Reservados todos os direitos.
 Confidado como secreto industrial. Nos reservamos todos los derechos.

Weitergabe sowie Vervielfältigung dieser Unterlage, Verwertung und Mitteilung ihres Inhalts nicht gestattet, soweit nicht ausdrücklich zugestanden. Zuwiderhandlungen verpflichten zu Schadenersatz. Alle Rechte vorbehalten, insbesondere für den Fall der Patenterteilung oder GM-Entragung.

Editor: Müller O.	17-Dec-97	Ignition	HMC_V6
Version: a 153589 from 18.12.97		657765.49.05	
File: CHAP_6.DOC	650H0000	Sourcefile:07601401.00D	Page 41 / 53

1.3.3.6 Gradient limitation for ignition angle with instationary correction (LV_TRA_KNK_ACT)

Input data:

LV_TRA_KNK_ACT	IGA_BAS	IGA_TRA_KNK	C_IGA_LGRD_2
----------------	---------	-------------	--------------

FUNCTION DESCRIPTION:

General information:

In order to obtain a soft engine torque built - up following instationary correction (IGA_TRA_KNK), the nominal ignition angle is reached with the general gradient limitation C_IGA_LGRD_2.

Description:

General Gradient Limitation :
C_IGA_LGRD_2
 x Segment (°CRK)

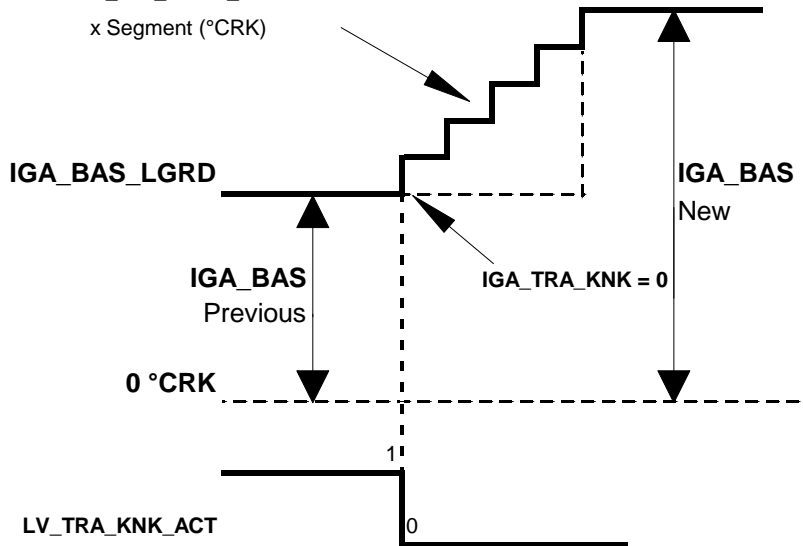

Proprietary data, company confidential. All rights reserved. Contient des informations confidentielles. Tous droits réservés. Comunicado como segredo empresarial. Reservados todos os direitos. Confidado como secreto industrial. Nos reservamos todos los derechos.

Weitergabe sowie Veröffentlichung dieser Unterlage, Verwertung und Mitteilung ihres Inhalts ist gestattet, soweit nicht ausdrücklich zugestanden. Zuwiderhandlungen verpflichten zu Schadensersatz. Alle Rechte vorbehalten, insbesondere für den Fall der Patenterteilung oder GM-Enttragung.

Editor: Müller O.	17-Dec-97	Ignition	HMC_V6
Version: a 153589 from 18.12.97		657765.49.05	
File: CHAP_6.DOC	650H0000	Sourcefile:07601401.00D	Page 42 / 53

Proprietary data, company confidential. All rights reserved.
 Contití a títre de secret d'entreprise. Tous droits réservés.
 Comunicado como secreto empresarial. Reservados todos os direitos.
 Confidado como secreto industrial. Nos reservamos todos los derechos.

Weitergabe sowie Vervielfältigung dieser Unterlage, Verwertung und Mitteilung ihres Inhalts nicht gestattet, soweit nicht ausdrücklich zugestanden. Zuwiderhandlungen verpflichten zu Schadensersatz. Alle Rechte vorbehalten, insbesondere für den Fall der Patenterteilung oder GM-Entragung.

1.3.3.7 Gradient limitation for ignition angle with knock detected

Input data:

KNK_INT_CYL_[CYL]	IGA_BAS		
-------------------	---------	--	--

FUNCTION DESCRIPTION:

Formula section:

If KNK_INT_CYL_[CYL] ≠ 0
and IGA_BAS_n ≤ IGA_BAS_{n-1}
then IGA_BAS_LGRD_n = IGA_BAS_n
Endif.

1.3.3.8 Gradient limitation for transition Part Load (PL) -> Idle Speed (IS)

Input data:

LV_PL	LV_IS		
-------	-------	--	--

FUNCTION DESCRIPTION:

In case of transition Part Load PL -> Idle Speed IS, a specific change limitation C_IGA_LGRD_PL_IS is applied to IGA_BAS_LGRD.

If Transition PL -> IS
Then
 a change limitation C_IGA_LGRD_PL_IS is applied on IGA_BAS_LGRD until target is reached

Calibration data:

Name	Dim	Hex. limits	Phys. limits	Resol.	Unit
C_IGA_LGRD_PL_IS	1	01...7FFFH	0,00146...48	48 / 32767	°CRK
Ignition angle gradient limitation in case of transition PL->IS					

Editor: Müller O.	17-Dec-97	Ignition	HMC_V6
Version: a 153589 from 18.12.97		657765.49.05	
File: CHAP_6.DOC	650H0000	Sourcefile:07601401.00D	Page 43 / 53

1.3.3.9 General gradient limitation for ignition angle

Input data:

MAF	N	IGA_BAS
-----	---	---------

FUNCTION DESCRIPTION:

General information:

In specific conditions different from the previous described conditions, a general gradient limitation C_IGA_LGRD_x is applied to the nominal ignition angle in order to limit ignition angle variations.

It's applied only in advance direction and is different for 3 engine operating areas (MAF, N).

Formula section:

```

If      MAF ≥ C_IGA_MAF_LGRD
then    C_IGA_LGRD_x = C_IGA_LGRD_3
else
    If      N ≥ C_IGA_N_LGRD
    then    C_IGA_LGRD_x = C_IGA_LGRD_2
    else    C_IGA_LGRD_x = C_IGA_LGRD_1
    
```

Description:

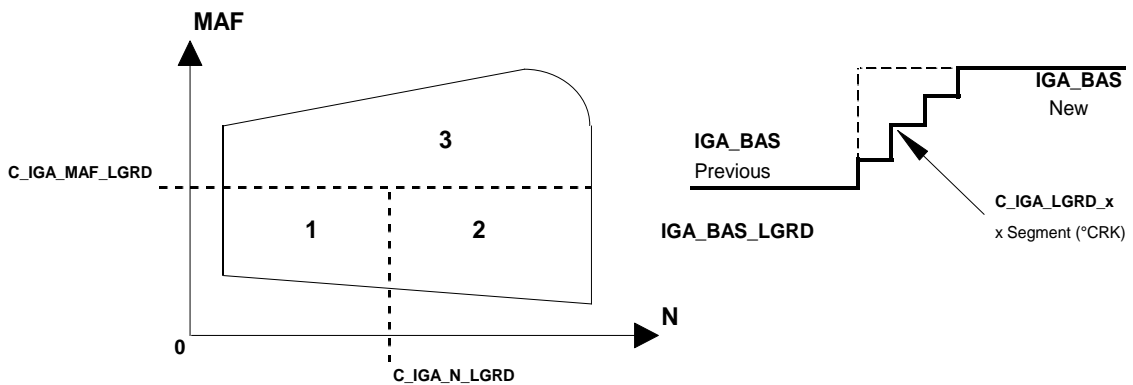

Proprietary data, company confidential. All rights reserved. Contine a titre de secret d'entreprise. Tous droits réservés. Comunicado como segredo empresarial. Reservados todos os direitos. Confidado como secreto industrial. Nos reservamos todos los derechos.

Weitergabe sowie Vervielfältigung dieser Unterlage, Verwertung und Mitteilung ihres Inhalts nicht gestattet, soweit nicht ausdrücklich zugestanden. Zuwiderhandlungen verpflichten zu Schadensersatz. Alle Rechte vorbehalten, insbesondere für den Fall der Patenterteilung oder GM-Enttragung.

Editor: Müller O.	17-Dec-97	Ignition	HMC_V6
Version: a 153589 from 18.12.97		657765.49.05	
File: CHAP_6.DOC	650H0000	Sourcefile:07601401.00D	Page 44 / 53

Calibration data:

Name	Dim	Hex. limits	Phys. limits	Resol.	Unit
C_IGA_LGRD_1	1	01...7FFFH	0,00146...48	48 / 32767	°CRK
Ignition angle gradient limitation for area 1 - (x Segment).					
C_IGA_LGRD_2	1	01...FFH	0,375...95,625	0,375	°CRK
Ignition angle gradient limitation for area 2 - (x Segment).					
C_IGA_LGRD_3	1	01...FFH	0,375...95,625	0,375	°CRK
Ignition angle gradient limitation for area 3 - (x Segment).					
C_IGA_N_LGRD	1	01...1FE0H	1...8160	1	rpm
Engine speed threshold for ignition angle gradient limitation choice.					
C_IGA_MAF_LGRD	1	01...FFH	5,45...1389	5,45	mg/TDC
Mass air flow threshold for ignition angle gradient limitation choice.					

Proprietary data, company confidential. All rights reserved.
 Contient des données confidentielles. Tous droits réservés.
 Comunicado como secreto empresarial. Reservados todos los derechos.
 Confiado como secreto industrial. Nos reservamos todos los derechos.

Weitergabe sowie Vervielfältigung dieser Unterlage, Verwertung und Mitteilung ihres Inhalts nicht gestattet, soweit nicht ausdrücklich zugestanden. Zuwiderhandlungen verpflichten zu Schadensersatz. Alle Rechte vorbehalten, insbesondere für den Fall der Patenterteilung oder GM-Eintragung.

Editor: Müller O.	17-Dec-97	Ignition	HMC_V6
Version: a 153589 from 18.12.97		657765.49.05	
File: CHAP_6.DOC	650H0000	Sourcefile:07601401.00D	Page 45 / 53

1.4 Knock control

1.4.1 General - Knock correction (IGA_KNK_[CYL])

Output data:

Name	Mode	Hex. limits	Phys. limits	Resol.	Unit
IGA_KNK_[CYL]	V	0...80H	-48...0	0.375	°CRK
Cylinder individual ignition angle knock correction.					
IGA_MV_KNK	V	0...80H	-48...0	0.375	°CRK
Ignition angle knock correction mean value.					

Input data:

LV_KNK_ACT	LV_KNK_1_ERR	LV_KNK_2_ERR	LV_CAM_ERR_LIH
LV_TRA_KNK_ACT	LV_IGA_ADJ_TQR	C_IGA_LGRD_3	LV_CRK_ERR_LIH
LV_IGA_CH	LV_TPS_FL	IGA_CH	

1.4.1.1 Conditions for knock control in normal operation or in limp home

Formula section:

If LV_KNK_ACT = 1 (Active) *(knock control active)*
then
 If LV_KNK_i_ERR = 0 *(no error currently present on knock acquisition (sensor n°i))*
 and LV_CAM_ERR_LIH = 0 *(no limp home for camshaft sensor)*
 and LV_CRK_ERR_LIH = 0 *(no limp home for crankshaft sensor)*
then Normal Operation for Knock Control
else Limp Home Operation for Knock Control

1.4.1.2 Ignition angle correction out of knock detection area

Formula section:

If LV_KNK_ACT = 0 (Passive) *(knock control passive)*
then

$$IGA_KNK_ [CYL]_n = IGA_KNK_ [CYL]_{n-1} + C_IGA_LGRD_3$$

until IGA_KNK_[CYL] = 0.

Editor: Müller O.	17-Dec-97	Ignition	HMC_V6
Version: a 153589 from 18.12.97		657765.49.05	
File: CHAP_6.DOC	650H0000	Sourcefile:07601601.00H	Page 46 / 53

Proprietary data, company confidential. All rights reserved. Contine a titre de secret d'entreprise. Tous droits réservés. Comunicado como segredo empresarial. Reservados todos os direitos. Confidado como secreto industrial. Nos reservamos todos los derechos.

Weitergabe sowie Vervielfältigung dieser Unterlage, Verwertung und Mitteilung ihres Inhalts nicht gestattet, soweit nicht ausdrücklich zugestanden. Zuwiderhandlungen verpflichten zu Schadenersatz. Alle Rechte vorbehalten, insbesondere für den Fall der Patenterteilung oder GM-Entragung.

1.4.1.3 Ignition angle knock correction mean value (IGA_MV_KNK)

General information:

Application recurrence : **720 °CRK.**

Formula section:

$$IGA_MV_KNK = 1 / NC_CYL_NO * \sum_{CYL = 1}^{NC_CYL_NO} IGA_KNK_ [CYL]$$

1.4.1.4 Relative knock corrections limitation

General information:

Application recurrence : **720 °CRK.**

Formula section:

If IGA_KNK_[CYL] > (IGA_MV_KNK + C_IGA_DIF_MAX_MIN_KNK)
then IGA_KNK_[CYL] = (IGA_MV_KNK + C_IGA_DIF_MAX_MIN_KNK)

If IGA_KNK_[CYL] < (IGA_MV_KNK - C_IGA_DIF_MAX_MIN_KNK)
then IGA_KNK_[CYL] = (IGA_MV_KNK - C_IGA_DIF_MAX_MIN_KNK)

1.4.1.5 Absolute knock corrections limitation

General information:

To prevent the ignition angle from a too large correction in the retard sense, the knock correction is limited to a maximum value. This maximum value is performed also for diagnosis functions.

Application recurrence : **720 °CRK.**

Formula section:

$$Limit\ MAXI = IP_IGA_MAX_KNK_N_32_MAF * IP_IGA_TCO_FAC_KNK_TCO$$

with
 Limit MAXI ≤ 0
and
 IGA_KNK_[CYL] ≥ Limit MAXI

If LV_IGA_CH = 1 (Active)
(catalyst heating function active - ignition angle intervention)
and LV_TPS_FL = 0 (Passive)
(no full load throttle position detected)
then Limit MAXI = Limit MAXI - IGA_CH

Editor: Müller O.	17-Dec-97	Ignition	HMC_V6
Version: a 153589 from 18.12.97		657765.49.05	
File: CHAP_6.DOC	650H0000	Sourcefile:07601601.00H	Page 47 / 53

Proprietary data, company confidential. All rights reserved. Contine a titre de secret d'entreprise. Tous droits réservés. Comunicado como segredo empresarial. Reservados todos os direitos. Confidado como secreto industrial. Nos reservamos todos los derechos.

Weitergabe sowie Vervielfältigung dieser Unterlage, Verwertung und Mitteilung ihres Inhalts nicht gestattet, soweit nicht ausdrücklich zugestanden. Zuwiderhandlungen verpflichten zu Schadensersatz. Alle Rechte vorbehalten, insbesondere für den Fall der Patenterteilung oder GM-Entragung

Calibration data:

Name	Dim	Hex. limits	Phys. limits	Resol.	Unit
IP_IGA_MAX_KNK__N_32__MAF	8 x 4	0...80H	-48...0	0.375	°CRK
Maximum ignition angle knock correction versus engine operating point.					
IP_IGA_TCO_FAC_KNK__TCO	8	00...FFH	0...0.997	3.895E-3	-
Weighting factor versus coolant temperature for determination of maximum ignition angle knock correction.					
C_IGA_DIF_MAX_MIN_KNK	1	0...80H	0...48	0.375	°CRK
Maximum difference between the individual knock corrections and the ignition angle knock correction mean value.					
NC_CYL_NO	1	0...FFH	0...255	1	-
Number of Cylinders - Non adjustable calibration.					

Applicative Value :

NC_CYL_NO = **06H** = 6 cylinders

Editor: Müller O.	17-Dec-97	Ignition	HMC_V6
Version: a 153589 from 18.12.97		657765.49.05	
File: CHAP_6.DOC	650H0000	Sourcefile:07601601.00H	Page 48 / 53

1.4.2 Knock control in normal operation

Input data:

IGA_KNK_[CYL]	N_KNK	LV_IGA_ADJ_TQR	NL_THD_KNK_[CYL]
MAF_KNK	LV_TRA_KNK_ACT	KNK_INT_CYL_[CYL]	
LV_KNK_ACT	KNKS_[CYL]	ID_IGA_AD_[CYL]__N_KNK__MAF_KNK	

Formula section:

1 - Knock ignition angle correction calculation according to knock ignition angle adaptation.

If LV_KNK_ACT = 0 (Passive) → 1 (Active) (knock control begins active)
then

$IGA_KNK_ [CYL] = ID_IGA_AD_ [CYL] _ _ N_KNK_ _ _ MAF_KNK$
--

2 - Knock ignition angle correction calculation in case of knock detected :

If LV_KNK_ACT = 1 (Active) (knock control continuously active)
then

if new operating point is detected by the system (N_KNK, MAF_KNK)

then

if ID_IGA_AD_[CYL]__N_KNK__MAF_KNK
 < (IGA_KNK_[CYL] - C_IGA_AD_DIF_MAX)

then

$IGA_KNK_ [CYL]_n = (IGA_KNK_ [CYL]_{n-1} - C_IGA_AD_DIF_MAX)$

else

if ID_IGA_AD_[CYL]__N_KNK__MAF_KNK
 > (IGA_KNK_[CYL] + C_IGA_AD_DIF_MAX)

then

$IGA_KNK_ [CYL]_n = (IGA_KNK_ [CYL]_{n-1} + C_IGA_AD_DIF_MAX)$

else

$IGA_KNK_ [CYL]_n = ID_IGA_AD_ [CYL] _ _ N_KNK_ _ _ MAF_KNK$
--

Proprietary data, company confidential. All rights reserved. Contine a titre de secret d'entreprise. Tous droits réservés. Comunicado como segredo empresarial. Reservados todos os direitos. Confidado como secreto industrial. Nos reservamos todos los derechos.

Weitergabe sowie Vervielfältigung dieser Unterlage, Verwertung und Mitteilung ihres Inhalts nicht gestattet, soweit nicht ausdrücklich zugestanden. Zuwiderhandlungen verpflichten zu Schadenersatz. Alle Rechte vorbehalten, insbesondere für den Fall der Patenterteilung oder GM-Entragung.

Editor: Müller O.	17-Dec-97	Ignition	HMC_V6
Version: a 153589 from 18.12.97		657765.49.05	
File: CHAP_6.DOC	650H0000	Sourcefile:07601601.00H	Page 49 / 53

(noise level threshold calculation for knock detection)
If KNKS_[CYL] ≥ NL_THD_KNK_[CYL]
then
 If KNK_INT_CYL_[CYL] = 1 (Intensity 1)
 (knock is detected with intensity 1)
 then

$$IGA_KNK_ [CYL]_n = IGA_KNK_ [CYL]_{n-1} - ID_IGA_DEC_1_KNK_N_KNK$$

else ← (KNK_INT_CYL_[CYL] = 2 (Intensity 2) :
 knock is detected with intensity 2)

$$IGA_KNK_ [CYL]_n = IGA_KNK_ [CYL]_{n-1} - ID_IGA_DEC_2_KNK_N_KNK$$

else ← (KNK_INT_CYL_[CYL] = 0 (No) : no knock detected)
If LV_TRA_KNK_ACT = 0 (Passive)
 (no ignition instationary correction requested)
then

$$IGA_KNK_ [CYL]_n = IGA_KNK_ [CYL]_{n-1} + ID_IGA_INC_KNK_N_KNK$$

else

$$IGA_KNK_ [CYL]_n = IGA_KNK_ [CYL]_{n-1}$$

Calibration data:

Name	Dim	Hex. limits	Phys. limits	Resol.	Unit
ID_IGA_DEC_1_KNK_N_KNK	3	01...7FH	0.375...47.625	0.375	°CRK
Update of knock ignition angle correction when knock intensity 1 is detected (x 720 °CRK).					
ID_IGA_DEC_2_KNK_N_KNK	3	01...7FH	0.375...47.625	0.375	°CRK
Update of knock ignition angle correction when knock intensity 2 is detected (x 720 °CRK).					
ID_IGA_INC_KNK_N_KNK	16	01...7FFFH	0.00146...48	0.00146	°CRK
Update of knock ignition angle correction when no knock is detected (x 720 °CRK).					
C_IGA_AD_DIF_MAX	1	0...7FH	0...47.625	0.375	°CRK
Maximum value for updating the knock ignition angle correction.					

1.4.3 Knock control in limp home

General information:

For explanations, refer to the chapter “ Knock Sensors Diagnosis (KNKS1, KNKS2) “ in the major chapter “Diagnosis Management “.

Editor: Müller O.	17-Dec-97	Ignition	HMC_V6
Version: a 153589 from 18.12.97		657765.49.05	
File: CHAP_6.DOC	650H0000	Sourcefile:07601601.00H	Page 50 / 53

1.4.4 Knock adaptation

Output data:

Name	Mode	Hex. limits	Phys. limits	Resol.	Unit
LV_IGA_AD_ACT	V	0...01H	0...1	1	-
Boolean information for knock adaptation loop 1 - (Passive / Active).					
LV_CYC_WUP_KNK	V	0...01H	0...1	1	-
Boolean information for warm up cycle fulfilled					

Input data:

LV_KNK_ACT	LV_KNK_1_ERR	LV_KNK_2_ERR	LV_IS
LV_N_GRD_MAX_KNK	LV_TPS_GRD_TRA_KNK	LV_TPS_ERR	LV_MAF_ERR
LV_TCO_ERR	LV_TIA_ERR	LV_ISA_1_ERR	LV_ISA_2_ERR
LV_LSH_UP_1_ERR	LV_LSH_UP_2_ERR	LV_CAM_ERR	LV_CRK_ERR
LV_IGA_ADJ_TQR	LV_STATE_A_MIS	LV_STATE_B_MIS	MAF_KNK
LV_IGA_CH	LV_TPS_FL	LV_SCC_TQR	N_32
LV_VLS_LIM_1_ERR	LV_VLS_LIM_2_ERR	IGA_MV_KNK	N_KNK

General information:

The adaptation assists the knock ignition angle correction IGA_KNK_[CYL] during transition from an engine operating point to another one.

An indexed table ID_IGA_AD_[CYL] __N_KNK__MAF_KNK is provided for each cylinder.

They are updated with the value of IGA_KNK_[CYL] determined for each operating point by the knock control.

Proprietary data, company confidential. All rights reserved. Contient des informations confidentielles. Tous droits réservés. Comunicado como segredo empresarial. Reservados todos os direitos. Confidado como secreto industrial. Nos reservamos todos los derechos.

Weitergabe sowie Vervielfältigung dieser Unterlage, Verbreitung und Mitteilung ihres Inhalts nicht gestattet, soweit nicht ausdrücklich zugestanden. Zuwiderhandlungen verpflichten zu Schadensersatz. Alle Rechte vorbehalten, insbesondere für den Fall der Patenterteilung oder GM-Entragung.

Editor:	Müller O.	17-Dec-97	Ignition	HMC_V6
Version:	a 153589 from 18.12.97		657765.49.05	
File:	CHAP_6.DOC	650H0000	Sourcefile:07601601.00H	Page 51 / 53

Formula section:

```

If      LV_KNK_ACT = 1 (Active)
           (knock control active)
and    LV_KNK_i_ERR = 0
           (no error currently present on knock sensors)
and    LV_IS = 0
           (engine operating state out of idle)
and    LV_N_GRD_MAX_KNK = 0 (Passive)
           (no engine speed dynamics relative to knock control)
and    LV_TPS_GRD_TRA_KNK = 0 (Active)
           (no load dynamics relative to knock control)
and    LV_TPS_ERR = 0
           (no error currently present on throttle position sensor)
and    LV_MAF_ERR = 0
           (no error currently present on mass air flow sensor)
and    LV_TCO_ERR = 0
           (no error currently present on coolant temperature sensor)
and    LV_TIA_ERR = 0
           (no error currently present on air temperature sensor)
and    LV_ISA_i_ERR = 0
           (no error currently present on idle charge actuator command signal (coil i))
and    LV_LSH_UP_i_ERR = 0
           (no error currently present on oxygen sensor upstream heater power stage)
and    LV_CAM_ERR = 0
           (no error currently present on camshaft sensor)
and    LV_CRK_ERR = 0
           (no error currently present on crankshaft sensor)
and    LV_DUR_IGC_[CYL]_ERR = 0
           (no error currently present on the corresponding ignition output)
and    LV_IV_[CYL]_ERR = 0
           (no error currently present on corresponding injector power stage)
and    LV_STATE_A_MIS = 0
           (no misfire status CARB A (catalyst damage))
and    LV_STATE_B_MIS = 0
           (no misfire status CARB B (increase emissions))

and    MAF_KNK ≥ ID_MAF_MIN_AD_KNK__N_32
and    LV_IGA_CH = 0 (Passive)
           (no catalyst heating function with ignition angle intervention)
or    LV_TPS_FL = 1 (Passive)
           (full load throttle position detected)

then

           LV_IGA_AD_ACT = 1 (Active)
           (knock adaptation loop 1 authorized)

and

```

ID_IGA_AD_[CYL]__N_KNK__MAF_KNK = IGA_KNK_[CYL]

```

else

           LV_IGA_AD_ACT = 0 (Passive)

```

Proprietary data, company confidential. All rights reserved. Contine a titre de secret d'entreprise. Tous droits réservés. Comunicado como segredo empresarial. Reservados todos os direitos. Confidado como secreto industrial. Nos reservamos todos los derechos.

Weitergabe sowie Vervielfältigung dieser Unterlage, Verbreitung und Mitteilung ihres Inhalts nicht gestattet, soweit nicht ausdrücklich zugestanden. Zuwiderhandlungen verpflichten zu Schadenersatz. Alle Rechte vorbehalten, insbesondere für den Fall der Patenterteilung oder GM-Entragung.

Editor:	Müller O.	17-Dec-97	Ignition	HMC_V6
Version:	a 153589 from 18.12.97		657765.49.05	
File:	CHAP_6.DOC	650H0000	Sourcefile:07601601.00H	Page 52 / 53

Proprietary data, company confidential. All rights reserved.
 Contine a titre de secret d'entreprise. Tous droits réservés.
 Comunicado como segredo empresarial. Reservados todos os direitos.
 Confidado como secreto industrial. Nos reservamos todos los derechos.

Weitergabe sowie Vervielfältigung dieser Unterlage, Verwertung und Mitteilung ihres Inhalts nicht gestattet, soweit nicht ausdrücklich zugestanden. Zuwiderhandlungen verpflichten zu Schadensersatz. Alle Rechte vorbehalten, insbesondere für den Fall der Patenterteilung oder GM-Entragung.

Remark :

- Storing the adaptation values (ID_IGA_AD_[CYL]) from knock adaptation loop in non volatile memory with ECU in power-latch :

The adaptation values from the indexed tables ID_IGA_AD_[CYL] are initialized to 0 if one of the following conditions are fulfilled:

- Virginal ECU
- Request from service tester
- EEPROM read failure

Each time during power latch: it is the mean value IGA_MV_KNK which is stored for each operating point. Thus, the 6 adaptation indexed tables ID_IGA_AD_[CYL] are equal.

All indexed tables ID_IGA_AD_[CYL] are increased by C_IGA_INC_AD degrees up to the maximum 0 if:

- LV_CYC_WUP_KNK = 1
- TCO was above 71°C at the last engine stop (vehicle was driven until engine warm)
- TCO has increased by more than 21°C since last engine stop

Thus, it is possible to slowly reduce high values once learnt, without the necessity to approach these points in steady state.

LV_CYC_WUP_KNK:

Conditions to reset: System reset
 Conditions to set: **If** LV_CYC_WUP = 1
then LV_CYC_WUP_KNK = 1

Calibration data:

Name	Dim	Hex. limits	Phys. limits	Resol.	Unit
ID_MAF_MIN_AD_KNK__N_32	16	0...FFH	0...1389	5.45	mg/TDC
Minimum engine load to take into account knock adaptation.					
ID_IGA_AD_[CYL]__N_KNK__MAF_KNK	16 x 4	0...80H	-48...0	0.375	°CRK
Cylinder individual ignition angle knock adaptation.					
C_IGA_INC_AD	1	0...10H	0...6	0.375	°CRK
Offset on ignition angle knock adaptation value when engine s topped.					

Editor: Müller O.	17-Dec-97	Ignition	HMC_V6
Version: a 153589 from 18.12.97		657765.49.05	
File: CHAP_6.DOC	650H0000	Sourcefile:07601601.00H	Page 53 / 53

Proprietary data, company confidential. All rights reserved.
Confie a titre de secret d'entreprise. Tous droits réservés.
Comunicado como segredo empresarial. Reservados todos os direitos.
Confidado como secreto industrial. Nos reservamos todos los derechos.

Weitergabe sowie Vervielfältigung dieser Unterlage, Verwertung und Mitteilung ihres Inhalts nicht gestattet, soweit nicht ausdrücklich zugestanden. Zuwiderhandlungen verpflichten zu Schadenersatz. Alle Rechte vorbehalten, insbesondere für den Fall der Patenterteilung oder GM-Entragung

Document: **Injection**

Project: **Engine Management System**
HMC_V6

Version: a

Date: 17-Dec-97

Number of pages: 121

Revision Code-No.: 153589 from 18.12.97

Construction protocol-No.:

Software version: 650H0000

	Name	Department	Phone	Date	Sign
Author	Müller O.	AT PT SI TSA 11	3211	09.12.97	
1. Check	Pioch O.	AT PT SI TSA 11	3212	09.12.97	
2. Check	Gessner S.	AT PT SI TSA 11	5398	09.12.97	
Responsible	Brückner D.	AT PT SI TSA 16	4279	09.12.97	

Version list

Proprietary data, company confidential. All rights reserved. Contine a titre de secret d'entreprise. Tous droits réservés. Comunicado como segredo empresarial. Reservados todos os direitos. Confidado como secreto industrial. Nos reservamos todos los derechos.

Weitergabe sowie Vervielfältigung dieser Unterlage, Wertung und Mitteilung ihres Inhalts nicht gestattet, soweit nicht ausdrücklich zugestanden. Zuwiderhandlungen verpflichten zu Schadensersatz. Alle Rechte vorbehalten, insbesondere für den Fall der Patenterteilung oder GM-Eintragung

Version	Date	Author	Comment, Description

Editor:	Müller O.	17-Dec-97	Injection	HMC_V6
Version:	a 153589 from 18.12.97		657765.49.06	
File:	CHAP_7.DOC	650H0000		Page 2 / 121

Table of contents

Page

1.1	General	21
1.1.1	Total formulas	21
1.1.1.1	Cranking injection time	22
1.1.1.1.1	First injection at engine stopped (LV_ES)	22
1.1.1.1.2	Injection time at start (LV_ST)	22
1.1.1.2	Nominal injection time (out of start)	23
1.1.1.2.1	Closed loop variant	23
1.1.1.2.2	Open loop variant	25
1.1.1.2.3	Global injection time correction (TI_FAC_COR)	26
1.1.1.3	Injection time mean value for injection phase determination (TI_MV)	27
1.1.1.4	Cylinder individual injection time	27
1.1.1.5	Multiplexed cylinder individual injection time	27
1.1.2	Injection phase SOI (Start), EOI (End)	28
1.1.3	Re-start correction factor (TI_ST_REST)	31
1.2	Calculation of injection time corrections	32
1.2.1	Calculation of cranking injection time corrections	32
1.2.1.1	First injection time (TIPR_CST)	32
1.2.1.2	Injection time at start (TI_CST)	34
1.2.2	Calculation of nominal injection time corrections	36
1.2.2.1	Basic injection time (TIB)	36
1.2.3	Injector dead time correction (TI_ADD_DLY)	37
1.2.3.1	Cold post-start correction (TI_CAST)	38
1.2.3.2	Warm-up correction (TI_WUP)	40
1.2.3.3	Catalyst heating correction (TI_CH)	41
1.2.3.4	Catalyst overheating prevention (TI_COP)	43
1.2.3.5	Full load enrichment correction (TI_FL)	46
1.2.3.6	Throttle acceleration enrichment correction (TI_TPS_AE)	47
1.2.3.7	Load acceleration enrichment correction (TI_MAF_AE)	51
1.2.3.8	Trailing throttle fuel reduction correction (TI_PUR)	55
1.2.3.9	Idle speed correction (TI_IS)	59
1.2.3.10	Altitude correction factor (TI_FAC_ALTI)	60
1.2.3.11	Acceleration enrichment correction (TI_AE)	61
1.2.4	Cylinder fuel shut-off	62
1.2.4.1	Progressive fuel cut-off (PUC) and rewetting in Part Load (PL)	64
1.2.5	Individual cylinder re-start fuel feed (TI_ADD_REAC_SCC_[CYL])	67
1.3	Lambda control (A/F regulation loop)	70
1.3.1	General	70
1.3.1.1	Conditions for lambda control	70
1.3.1.1.1	Closing conditions	71
1.3.1.1.2	Lambda controller status definition following A/F regulation in open loop	72
1.3.1.1.3	Lambda controller status definition relative to the A/F regulation loop	73
1.3.1.1.4	Opening conditions	74
1.3.2	Variables related to A/F regulation oxygen sensors signal voltages (VLS_i)	77
1.3.2.1	Rich and lean mixture voltage thresholds (VLS_AFR_i, VLS_AFL_i)	81
1.3.2.2	A/F regulation oxygen sensors operability (LV_LS_i)	83
1.3.3	Variables related to A/F regulation oxygen sensors heater (LSHPWM_i)	85
1.3.3.1	Initialization	86
1.3.3.2	Oxygen sensors duty cycle gradient limitation (LSHPWM_LGRD_i)	86
1.3.3.3	Oxygen sensors preliminary heating phase (LV_LSH_PHA_AST)	87

Proprietary data, company confidential. All rights reserved.
 Contient des informations confidentielles de la société. Tous droits réservés.
 Comunicado como segredo empresarial. Reservados todos os direitos.
 Confidado como secreto industrial. Nos reservamos todos los derechos.

Weitergabe sowie Vervielfältigung dieser Unterlage, Verwertung und Mitteilung ihres Inhalts nicht gestattet, soweit nicht ausdrücklich zugestanden. Zuwiderhandlungen verpflichten zu Schadenersatz. Alle Rechte vorbehalten, insbesondere für den Fall der Patenterteilung oder GM-Entragung.

Editor:	Müller O.	17-Dec-97	Injection	HMC_V6
Version:	a 153589 from 18.12.97		657765.49.06	
File:	CHAP_7.DOC	650H0000		Page 3 / 121

1.3.3.4	Oxygen sensors full rate heating phase (LV_LSH_PHA_MAX_RATE)	88
1.3.3.5	Oxygen sensors heater controller	88
1.3.3.5.1	A/F regulation in open loop (LV_LSCL_i = 0 (OFF))	88
1.3.3.5.2	A/F regulation in closed loop (LV_LSCL_i = 1 (ON))	89
1.3.4	Lambda control (TI_LAM_i)	93
1.3.4.1	Lambda controller limits	97
1.3.4.2	LAM_i and LAM_MV_i calculation	99
1.3.4.3	Conditions for limited dynamics	101
1.3.5	Lambda adaptation (TI_AD_ADD_MMV_COR_i, TI_AD_FAC_MMV_COR_i)	103
1.3.5.1	Application conditions (LV_TI_AD_ACT_i)	104
1.3.5.2	Learning area (TI_AD_ACT_i)	105
1.3.5.3	Lambda adaptation calculation period	106
1.3.5.4	Correlation factor for lambda adaptation calculation	106
1.3.5.5	Lambda adaptation calculation (TI_AD_ADD_MMV_i, TI_AD_FAC_MMV_i)	107
1.3.5.6	Lambda adaptation correction during warm-up	108
1.3.5.7	Lambda adaptation limitation	109
1.3.6	Downstream fuel trim regulation by LAM - P - Jump delay time	111
1.3.7	Catalyst enrichment function after PUC phase (CAT - purge function)	116
1.3.7.1	Oxygen-sensor heater downstream from catalyst	119

Proprietary data, company confidential. All rights reserved.
 Contine a titre de secret d'entreprise. Tous droits réservés.
 Comunicado como segredo empresarial. Reservados todos os direitos.
 Confidado como secreto industrial. Nos reservamos todos los derechos.

Weitergabe sowie Vervielfältigung dieser Unterlage, Verwertung und Mitteilung ihres Inhalts nicht gestattet, soweit nicht ausdrücklich zugestanden. Zuwiderhandlungen verpflichten zu Schadensersatz. Alle Rechte vorbehalten, insbesondere für den Fall der Patenterteilung oder GM-Entragung.

Editor:	Müller O.	17-Dec-97	Injection	HMC_V6
Version:	a 153589 from 18.12.97		657765.49.06	
File:	CHAP_7.DOC	650H0000		Page 4 / 121

Index

Page

C

C_CAT_DIAG_MAX_DLY	
def.....	114
C_CRLC_DLY_AD	
def.....	115
C_CYC_MAX_AE	
def.....	54
C_EOI_N_MAX	
def.....	30
C_FAC_MIN_P_CP	
use.....	103
C_IGA_MIN_COP	
def.....	45
C_LAM_SUM_P_IS	
def.....	96
C_LAM_AD_SUM_P	
def.....	110
C_LAM_AD_SUM_P_IS	
def.....	110
C_LAM_CYCNR	
def.....	76
C_LAM_FAC_I_1	
def.....	96
C_LAM_FAC_I_2	
def.....	96
C_LAM_FAC_P	
def.....	96
C_LAM_INI_MAX	
def.....	84
C_LAM_MAF_KGH_MIN_DIAG	
def.....	76
C_LAM_MAX	
def.....	98
use.....	83
C_LAM_MIN	
def.....	98
C_LAM_MV_DYW	
def.....	102
C_LAM_N_MIN	
def.....	76
C_LAM_NEG_I_IS	
def.....	96
C_LAM_NEG_P_IS	
def.....	96
C_LAM_POS_I_IS	
def.....	96
C_LAM_POS_P_IS	
def.....	96
C_LAM_TCO_VLS_MIN_INI	
def.....	80
use.....	81, 83
C_LAM_TEMP_HYS_CAT_DLY	

Proprietary data, company confidential. All rights reserved.
 Contit a titre de secret d'entreprise. Tous droits réservés.
 Comunicado como segredo empresarial. Reservados todos os direitos.
 Confidado como secreto industrial. Nos reservamos todos los derechos.

Weitergabe sowie Vervielfältigung dieser Unterlage, Verwertung und Mitteilung ihres Inhalts nicht gestattet, soweit nicht ausdrücklich zugestanden. Zuwiderhandlungen verpflichten zu Schadensersatz. Alle Rechte vorbehalten, insbesondere für den Fall der Patenterteilung oder GM-Entragung.

Editor:	Müller O.	17-Dec-97	Injection	HMC_V6
Version:	a 153589 from 18.12.97		657765.49.06	
File:	CHAP_7.DOC	650H0000		Page 5 / 121

Proprietary data, company confidential. All rights reserved.
 Contient des données confidentielles de l'entreprise. Tous droits réservés.
 Comunicado como secreto empresarial. Reservados todos los derechos.
 Confidado como secreto industrial. Nos reservamos todos los derechos.

Weitergabe sowie Vervielfältigung dieser Unterlage, Wertung und Mitteilung ihres Inhalts nicht gestattet, soweit nicht ausdrücklich zugestanden. Zuwiderhandlungen verpflichten zu Schadensersatz. Alle Rechte vorbehalten, insbesondere für den Fall der Patenterteilung oder GM-Enttragung

def.....	114
C_LAM_TEMP_MIN_CAT_DLY	
def.....	114
C_LSHPWM_1_AS	
def.....	91
C_LSHPWM_2_AS	
def.....	91
C_LSHPWM_CAT_INI_1	
def.....	121
C_LSHPWM_CAT_INI_2	
def.....	121
C_LSHPWM_DIF_PUC	
def.....	91
C_LSHPWM_FAC_INI	
def.....	92
C_LSHPWM_FAC_MAX	
def.....	91
C_LSHPWM_FAC_MIN	
def.....	91
C_LSHPWM_INI_1	
def.....	91
C_LSHPWM_INI_2	
def.....	91
C_LSHPWM_LAM_P_SUM_FAC	
def.....	91
C_LSHPWM_LGRD_MAX_CAT	
def.....	121
C_LSHPWM_LGRD_NEG_CAT	
def.....	121
C_LSHPWM_LGRD_POS_CAT	
def.....	121
C_LSHPWM_T_FAC	
def.....	91
C_LSHPWM_T_FAC_CAT	
def.....	121
C_MAF_DYW	
def.....	102
C_MAF_INT_DLY_PUC_MAX	
def.....	118
C_MAF_INT_MIN_DLY	
def.....	114
C_MAF_INT_MIN_DLY_PUC	
def.....	114
C_MAF_INT_PUC_MIN	
def.....	118
C_MAF_LAM_DLY_P_MAX	
def.....	114
C_MAF_LAM_DLY_P_MIN	
def.....	114
C_MAF_MIN_HYS_COP	
def.....	45
C_N_DYW	
def.....	102
C_N_LAM_DLY_P_MAX	
def.....	114
C_N_LAM_DLY_P_MIN	
def.....	114

Editor: Müller O.	17-Dec-97	Injection	HMC_V6
Version: a 153589 from 18.12.97		657765.49.06	
File: CHAP_7.DOC	650H0000		Page 6 / 121

Proprietary data, company confidential. All rights reserved.
 Contitue a titre de secret d'entreprise. Tous droits réservés.
 Comunicado como segredo empresarial. Reservados todos os direitos.
 Confidado como secreto industrial. Nos reservamos todos los derechos.

Weitergabe sowie Vervielfältigung dieser Unterlage, Verwertung und Mitteilung ihres Inhalts nicht gestattet, soweit nicht ausdrücklich zugestanden. Zuwiderhandlungen verpflichten zu Schadensersatz. Alle Rechte vorbehalten, insbesondere für den Fall der Patenterteilung oder GM-Entragung

C_SOI_CAM_DIAG	
def.....	30
C_T_DLY_AD_DEC	
def.....	115
C_T_DLY_AD_MAX	
def.....	115
C_T_DLY_AD_MIN	
def.....	115
C_T_DLY_I_MAX	
def.....	115
C_T_DLY_I_MIN	
def.....	115
C_T_LAM_DLY_NEG_IS	
def.....	96
C_T_LAM_DLY_POS_IS	
def.....	96
C_T_LAM_MAX_STATE	
use.....	70
C_T_MAX_LSH_CAT_ST	
def.....	121
C_T_MIN_LS	
def.....	84
use.....	70, 85
C_T_PER_LSH	
def.....	91
C_T_PER_LSH_CAT	
def.....	121
C_T_VLS_FL	
def.....	80
C_TCO_AE_RST	
def.....	54
C_TCO_DLY_PUC_MIN	
def.....	118
C_TCO_MAX_TIPR_SEQ	
def.....	30
C_TCO_PAT_REAC_MIN	
def.....	66
C_TEMP_MIN_SUB_CAT_ST	
def.....	121
C_TI_AD_ADD_MAX	
def.....	110
use.....	21
C_TI_AD_ADD_MIN	
def.....	110
C_TI_AD_COR_CRLC	
def.....	110
C_TI_AD_COR_CRLC_CP	
def.....	110
C_TI_AD_COR_CRLC_IS	
def.....	110
C_TI_AD_COR_CRLC_LD	
def.....	110
C_TI_AD_FAC_MAX	
def.....	110
C_TI_AD_FAC_MIN	
def.....	110
C_TI_COP_COR	

Editor: Müller O.	17-Dec-97	Injection	HMC_V6
Version: a 153589 from 18.12.97		657765.49.06	
File: CHAP_7.DOC	650H0000		Page 7 / 121

def.....	45
use.....	21
C_TI_COP_INC	
def.....	45
C_TI_MAF_AD_ADD_MAX(_AT)	
def.....	110
C_TI_MAF_AD_FAC_MIN(_AT)	
def.....	110
C_TI_MAF_AD_MAX	
def.....	110
C_TI_MIN	
def.....	27
C_TI_N_AD_ADD_MAX(_AT)	
def.....	110
use.....	21
C_TI_N_AD_FAC_MIN(_AT)	
def.....	110
C_TI_TCO_AD_MIN	
def.....	110
C_TI_TIA_AD_MAX	
def.....	110
C_TI_VS_MAX_COR	
use.....	21, 43
C_TIPR_END	
def.....	30
C_TPS_CYCNR_MIN_AE	
def.....	50
C_VB_MIN_JUMP	
use.....	85
C_VLS_CAT_DLY_MAX_PUC	
def.....	118
C_VLS_CRLC	
def.....	80
C_VLS_FAC_AFL	
def.....	82
C_VLS_FAC_AFR	
def.....	82
C_VLS_INI	
def.....	80
use.....	81, 83
C_VLS_INI_MIN	
def.....	80
use.....	81, 83
C_VLS_LGRD_DEC_FL	
def.....	80
C_VLS_MMV_HYS	
def.....	80
C_VLS_SP	
def.....	91
C_VLS_SUBT_BOL_FL	
def.....	80
CAT_DIAG_TRIM_i	
use.....	111, 116
CONF_LAM	
use.....	21
CPPWM	
use.....	70, 97, 103

Editor: Müller O.	17-Dec-97	Injection	HMC_V6
Version: a 153589 from 18.12.97		657765.49.06	
File: CHAP_7.DOC	650H0000		Page 8 / 121

Proprietary data, company confidential. All rights reserved.
 Contient des informations confidentielles. Tous droits réservés.
 Comunicado como secreto empresarial. Reservados todos os direitos.
 Confidado como secreto industrial. Nos reservamos todos los derechos.

Weitergabe sowie Vervielfältigung dieser Unterlage, Verwertung und Mitteilung ihres Inhalts ist gestattet, soweit nicht ausdrücklich zugestanden. Zuwiderhandlungen verpflichten zu Schadenersatz. Alle Rechte vorbehalten, insbesondere für den Fall der Patenterteilung oder GM-Entragung

CYCNR_ES_ST	
use.....	34
CYCNR_ST_AST	
use.....	38
E	
EOI	
def.....	28
EOI_TIPR	
def.....	28
F	
FAC_CAT_DLY_i	
def.....	111
G	
GR_MT	
use.....	64
I	
ID_MAF_TPS_FAC_AE(_AT)_MAF	
def.....	50
ID_PAT_CYCNR_REAC_N_32__GR_MT	
def.....	66
ID_PAT_INH_IV__PAT_INH_IV	
def.....	63
ID_PAT_INH_IV_PUC_1__N_32	
def.....	66
ID_PAT_INH_IV_PUC_2__N_32	
def.....	66
ID_PAT_INH_IV_REAC__N_32__GR_MT	
def.....	66
ID_TCO_LAM_MIN__TCO_ST	
def.....	76
use.....	43
ID_TCO_LAM_MIN_IS__TCO_ST	
def.....	76
ID_TI_DEC_WF__N_32	
def.....	69
ID_TI_INC_WF__N_32	
def.....	69
ID_TI_N_POS_RG__N_32	
def.....	69
ID_TI_TCO_NEG_WF__TCO	
def.....	69
ID_TI_TCO_POS_WF__TCO	
def.....	69
ID_TPS_GRD_ADD_AE__TCO	
use.....	47, 51
ID_TPS_GRD_BOL_AE__N_32__TPS	
use.....	47, 51
IGA_COP	
def.....	43
IGA_MV_KNK	
use.....	43
IGA_TIA_TCO	
use.....	43
INH_SWI_IV	

Editor: Müller O.	17-Dec-97	Injection	HMC_V6
Version: a 153589 from 18.12.97		657765.49.06	
File: CHAP_7.DOC	650H0000		Page 9 / 121

def.....	62
IP_CRLC_DLY_I_MAF_KGH	
def.....	115
IP_DEC_CYCNR_LSH_MAF_KGH	
def.....	91
IP_EOI_N_32	
def.....	30
IP_EOI_TIPR	
def.....	30
IP_FAC_CAT_DLY_CAT_DIAG_TRIM_i	
def.....	115
IP_FAC_CAT_DLY_PUC_CAT_DIAG_TRIM_i	
def.....	118
IP_FAC_DLY_P_MAF_KGH	
def.....	115
IP_FAC_LAM_DLY_N_32_MAF	
def.....	115
IP_LAM_NEG_I_N_MAF	
def.....	96
IP_LAM_NEG_P_N_MAF	
def.....	96
IP_LAM_POS_I_N_MAF	
def.....	96
IP_LAM_POS_P_N_MAF	
def.....	96
IP_LSHPWM_1_N_32_MAF	
def.....	91
IP_LSHPWM_2_N_32_MAF	
def.....	91
IP_LSHPWM_CAT_1_N_32_MAF	
def.....	121
IP_LSHPWM_CAT_2_N_32_MAF	
def.....	121
IP_LSHPWM_CYCNR_TIA_ST	
def.....	91
IP_LSHPWM_DIF_I_1_VLS_DIF_1	
def.....	91
IP_LSHPWM_DIF_I_2_VLS_DIF_2	
def.....	91
IP_LSHPWM_LGRD_NEG_MAF_KGH	
def.....	91
IP_LSHPWM_LGRD_POS_MAF_KGH	
def.....	91
IP_LSHPWM_VB_FAC_VB	
def.....	91
IP_LSHPWM_VB_FAC_CAT_VB	
def.....	121
IP_MAF_INT_DLY_PUC_MAF_INT_PUC_i	
def.....	118
IP_MAF_LAM_DLY_AD_MAX_N_32	
def.....	115
IP_MAF_LAM_DLY_AD_MIN_N_32	
def.....	115
IP_MAF_LAM_DLY_I_MAX_N_32	
def.....	115
IP_MAF_LAM_DLY_I_MIN_N_32	
def.....	115

Editor: Müller O.	17-Dec-97	Injection	HMC_V6
Version: a 153589 from 18.12.97		657765.49.06	
File: CHAP_7.DOC	650H0000		Page 10 / 121

IP_MAF_MIN_COP__N_32_IGA_COP	
def.....	45
IP_SOI__N_32_TI_MV	
def.....	30
IP_SOI_ST__N_32_TI_MV	
def.....	30
IP_SOI_TCO__TCO	
def.....	30
IP_T_DLY_I_VLS__DIF_DLY_i	
def.....	115
IP_T_DLY_P__VLS_DIF_DLY_i	
def.....	115
IP_T_DLY_PUC__MAF_KGH	
def.....	118
IP_T_LAM_DLY_NEG__N_MAF	
def.....	96
IP_T_LAM_DLY_POS__N_MAF	
def.....	96
IP_T_MAX_LSH_ST__TCO_ST	
def.....	91
IP_TI_AD_ADD_FAC__TCO__TI_AD_ADD_MMV	
def.....	110
IP_TI_AD_FAC_FAC__TCO__TI_AD_FAC_MMV	
def.....	110
IP_TI_ADD_DLY__VB	
def.....	37
IP_TI_AST_REST__TCO	
def.....	39
IP_TI_CAST(_AT)__TIA__TCO_ST	
def.....	39
IP_TI_CH__N_32_MAF	
def.....	42
IP_TI_COP__N_32_MAF	
def.....	45
IP_TI_COP_IGA__IGA_COP	
def.....	45
IP_TI_CST(_AT)__N__TCO_ST	
def.....	35
IP_TI_CYCNR_AE(_AT)__N_32__TCO	
def.....	54
IP_TI_CYCNR_PUR(_AT)__N_32__TCO	
def.....	58
IP_TI_DEAC_CAST(_AT)__CYCNR_ST_AST__TCO_ST	
def.....	39
IP_TI_DEAC_CST(_AT)__CYCNR_ES_ST__TCO_ST	
def.....	35
IP_TI_FAC_1_AE_RST(_AT)__CYC	
def.....	54
IP_TI_FAC_2_AE_RST(_AT)__CYC	
def.....	54
IP_TI_FAC_AE(_AT)__N_32_MAF	
def.....	54
IP_TI_FAC_ALTI__MAF_FAC_ALTI_MMV	
def.....	33, 60
IP_TI_FAC_CH__TCO__T_AST	
def.....	42
IP_TI_FAC_NOT_CAT__TCO	

Editor:	Müller O.	17-Dec-97	Injection	HMC_V6
Version:	a 153589 from 18.12.97		657765.49.06	
File:	CHAP_7.DOC	650H0000		Page 11 / 121

def.....	27
IP_TI_FAC_PUR(_AT)_N_32_MAF	
def.....	58
IP_TI_FAC_PUR_RST(_AT)_CYC	
def.....	58
IP_TI_FAC_TRA_AE(_AT)_MAF_RATIO_AE_TCO	
def.....	54
IP_TI_FAC_TRA_PUR(_AT)_MAF_RATIO_PUR_TCO	
def.....	58
IP_TI_FL_N	
def.....	46
IP_TI_IS_N_DIF_COR	
def.....	59
IP_TI_LGRD_AST_TCO	
def.....	35
use.....	21
IP_TI_NOT_CAT_N_32_MAF	
def.....	27
IP_TI_ST_REST_TCO	
def.....	31
IP_TI_TCO_CH_TCO	
def.....	42
IP_TI_TCO_CH_IS_TCO	
def.....	42
IP_TI_TCO_WUP(_AT)_TCO_TCO_ST	
def.....	40
IP_TI_TCO_WUP_ASR_TCO_TCO_ST	
def.....	40
IP_TI_TPS_FAC_AE(_AT)_TCO_TPS_GRD	
def.....	50
IP_TI_WUP(_AT)_N_32_MAF	
def.....	40
IP_TIB_N_MAF	
def.....	36
IP_TIPR_CST(_AT)_TCO	
def.....	33
IP_TIPR_FAC_ST_ES(_AT)_TCO	
def.....	33
IP_TPS_CYCNR_AE(_AT)_N_32	
def.....	50
IP_TPS_SUM_CYCNR_AE_N_32	
def.....	50
IP_VLS_SP_DLY_N_32_MAF	
def.....	114
L	
L_INH_IV_[CYL]	
use.....	70
LAM_1.....	99
LAM_2.....	99
LAM_MV_1.....	99
use.....	101
LAM_MV_2.....	99
use.....	101
LAM_MV_DYW_1.....	101
LAM_MV_DYW_2.....	101
LAM_MV_DYW_i.....	101

Editor: Müller O.	17-Dec-97	Injection	HMC_V6
Version: a 153589 from 18.12.97		657765.49.06	
File: CHAP_7.DOC	650H0000		Page 12 / 121

use.....	70, 103
LAM_MV_i	
use.....	70, 103
LAM_TRA	
use.....	21
LSHPWM_CAT_i.....	119
LSHPWM_CAT_LGRD_i.....	119
LSHPWM_CYCNR.....	85
LSHPWM_FAC_i.....	85
LSHPWM_i.....	85
LSHPWM_LGRD_i.....	85
LV_ACT_INT_PUC_i	
def.....	116
use.....	111
LV_AE	
use.....	47, 51, 61
LV_AFR_1	
use.....	93, 99
LV_AFR_2	
use.....	93, 99
LV_AFR_i	
def.....	81
use.....	70
LV_AUTH_LAM_AD_CP	
use.....	103
LV_AUTH_LAM_CYCNR	
def.....	70
LV_AUTH_LAM_i_AD_LEARN_CP	
use.....	103
LV_AUTH_LAM_SA	
use.....	70
LV_CAM_ERR	
use.....	103, 111
LV_COP	
def.....	43
use.....	21, 70
LV_CPS_ERR	
use.....	70, 103, 111
LV_CPS_MECHA_ERR	
use.....	70, 103, 111
LV_CRK_ERR	
use.....	111
LV_CRK_ERR_LIH	
use.....	28
LV_DUR_IGC_[CYL]_ERR	
use.....	70
LV_ES	
use.....	21, 32, 34, 36, 70, 77, 83, 85, 119
LV_FL	
use.....	46, 70, 77
LV_FSD_ERR	
use.....	103
LV_FSD_i_ERR	
use.....	111
LV_IGA_AST	
use.....	70
LV_IGK	

Editor: Müller O.	17-Dec-97	Injection	HMC_V6
Version: a 153589 from 18.12.97		657765.49.06	
File: CHAP_7.DOC	650H0000		Page 13 / 121

Proprietary data, company confidential. All rights reserved.
 Contient des données confidentielles de l'entreprise. Tous droits réservés.
 Comunicado como secreto empresarial. Reservados todos los derechos.
 Confidado como secreto industrial. Nos reservamos todos los derechos.

Weitergabe sowie Vervielfältigung dieser Unterlage, Verwertung und Mitteilung ihres Inhalts ist gestattet, soweit nicht ausdrücklich zugestanden. Zuwiderhandlungen verpflichten zu Schadensersatz. Alle Rechte vorbehalten, insbesondere für den Fall der Patenterteilung oder GM-Enttragung

use.....	62
LV_IS	
use.....	21, 41, 59, 93, 103
LV_ISA_i_ERR	
use.....	103
LV_ISA_MECHA_ERR	
use.....	103
LV_ISAPWM_IS_ACT	
use.....	59
LV_IV_[CYL]_ERR	
use.....	70
LV_LAM_ACT_i	
def.....	70
use.....	77, 85
LV_LAM_DLY_i	
def.....	111
LV_LAM_DYW_1	
def.....	101
LV_LAM_DYW_2	
def.....	101
LV_LAM_DYW_i	
use.....	103
LV_LAM_i_READY	
def.....	70
LV_LAM_LIM_i_ERR	
use.....	70, 103
LV_LAM_STOP	
use.....	111
LV_LDC_CAT_i	
use.....	111
LV_LEARN_CP	
use.....	70, 97, 101
LV_LS_i	
def.....	83
use.....	70, 77, 85
LV_LSCL_1	
use.....	43, 93
LV_LSCL_2	
use.....	43, 93
LV_LSCL_i	
def.....	70
use.....	77, 103, 111
LV_LSH_CAT_PHA_MAX_RATE	
def.....	119
use.....	116
LV_LSH_DOWN_HP_i_ERR	
use.....	111
LV_LSH_DOWN_i_ERR	
use.....	111
LV_LSH_PHA_AST	
def.....	85
LV_LSH_PHA_MAX_RATE	
def.....	85
use.....	70
LV_LSH_UP_i_ERR	
use.....	70, 85, 111
LV_MAF_ERR	

Editor: Müller O.	17-Dec-97	Injection	HMC_V6
Version: a 153589 from 18.12.97		657765.49.06	
File: CHAP_7.DOC	650H0000		Page 14 / 121

use.....	41, 70, 103, 111
LV_MAF_PLAUS_ERR	
use.....	103, 111
LV_MIS_[CYL]_ERR	
use.....	111
LV_N_MAF_DYW_1	
def.....	101
LV_N_MAF_DYW_2	
def.....	101
LV_N_MAF_DYW_i	
use.....	103
LV_OPL_VS_MAX	
use.....	70
LV_PL	
use.....	21, 46, 64, 93, 103
LV_PU	
use.....	64
LV_PUC	
use.....	64, 70, 85, 116
LV_PUR	
use.....	55
LV_REST	
use.....	31
LV_SAS_ERR	
use.....	111
LV_SAV_ERR	
use.....	103, 111
LV_SAV_MECHA_ERR	
use.....	103, 111
LV_SCC_LAM_ASR	
use.....	70
LV_SCC_TQR	
use.....	40
LV_SLOP_CP	
use.....	93
LV_ST	
use.....	21, 28, 32, 34, 36, 38, 70, 85, 119
LV_ST_ES	
use.....	32
LV_STATE_A_MIS	
use.....	70
LV_STB_PHA_CP	
use.....	103
LV_SYN_ENG	
use.....	34
LV_T_DLY_AD_i	
def.....	111
LV_TCO_ERR	
use.....	64, 70, 103, 111
LV_TCO_PLAUS_ERR	
use.....	103
LV_TI_AD_ACT_i	
def.....	103
LV_TI_AST	
use.....	21, 34, 38, 70
LV_TI_CH	
use.....	41

Editor: Müller O.	17-Dec-97	Injection	HMC_V6
Version: a 153589 from 18.12.97		657765.49.06	
File: CHAP_7.DOC	650H0000		Page 15 / 121

Proprietary data, company confidential. All rights reserved.
 Contient des données confidentielles de l'entreprise. Tous droits réservés.
 Comunicado como secreto empresarial. Reservados todos los derechos.
 Confiado como secreto industrial. Nos reservamos todos los derechos.

Weitergabe sowie Vervielfältigung dieser Unterlage, Wertung und Mitteilung ihres Inhalts nicht gestattet, soweit nicht ausdrücklich zugestanden. Zuwiderhandlungen verpflichten zu Schadensersatz. Alle Rechte vorbehalten, insbesondere für den Fall der Patenterteilung oder GM-Entragung.

LV_TIA_ERR	
use.....	103
LV_TIPR_EOI_STOP	
def.....	28
LV_TIPR_SEQ	
def.....	28
LV_TPS_AE	
def.....	47
LV_TPS_ERR	
use.....	103, 111
LV_TPS_PLAUS_ERR	
use.....	103, 111
LV_VB_JUMP	
use.....	85, 119
LV_VLS_DOWN_i_ERR	
use.....	111
LV_VLS_DOWN_LIM_i_ERR	
use.....	111
LV_VLS_FREQ_i_ERR	
use.....	111
LV_VLS_LIM_ERR	
use.....	103
LV_VLS_LIM_i_ERR	
use.....	81, 83, 111
LV_VLS_SLOP_i_ERR	
use.....	111
LV_VLS_UP_i_ERR	
use.....	70, 77, 81, 83, 111
LV_VS_MAX	
use.....	21, 43
M	
MAF	
use.....	36, 40, 41, 43, 47, 51, 55, 85, 93, 101, 103, 111, 119
MAF_FAC_ALTI_MMV	
use.....	32, 60
MAF_INT_DLY_i	
def.....	111
MAF_INT_DLY_PUC_i	
def.....	116
MAF_INT_PUC_i	
def.....	116
MAF_KGH	
use.....	70, 85, 103, 111, 116
MAF_MV_1	
def.....	101
MAF_MV_2	
def.....	101
MAF_RATIO_AE	
use.....	51
MAF_RATIO_PUR	
use.....	55
N	
N	
use.....	21, 34, 46, 93, 101, 103, 119
N_32	

Editor: Müller O.	17-Dec-97	Injection	HMC_V6
Version: a 153589 from 18.12.97		657765.49.06	
File: CHAP_7.DOC	650H0000		Page 16 / 121

Proprietary data, company confidential. All rights reserved.
 Contient des informations confidentielles. Tous droits réservés.
 Comunicado como secreto empresarial. Reservados todos los derechos.
 Confidado como secreto industrial. Nos reservamos todos los derechos.

Weitergabe sowie Vervielfältigung dieser Unterlage, Verwertung und Mitteilung ihres Inhalts nicht gestattet, soweit nicht ausdrücklich zugestanden. Zuwiderhandlungen verpflichten zu Schadensersatz. Alle Rechte vorbehalten, insbesondere für den Fall der Patenterteilung oder GM-Entragung.

use.....	28, 36, 40, 41, 43, 47, 51, 55, 64, 67, 70, 85, 111
N_DIF_COR	
use.....	59
N_MV_1	
def.....	101
N_MV_2	
def.....	101
NC_CYL_NO	
use.....	64
NC_INI_INH_SWI_IV_SHIFT_NR	
def.....	63
use.....	64
NC_LSHPWM_LGRD_MIN	
def.....	92
NC_LSHPWM_MAX_DIAG	
def.....	92
NC_LSHPWM_MIN_DIAG	
def.....	92
NC_MAX_EOI	
def.....	30
P	
PAT_INH_IV	
def.....	62
use.....	70
PAT_INH_IV_N_MAX	
use.....	62
PAT_INH_IV_PUC_REAC	
def.....	64
use.....	62
PAT_INH_IV_TQR	
use.....	62
PAT_INH_IV_VS_MAX	
use.....	62
S	
SOI	
def.....	28
SOI_AS	
use.....	28
SOI_TIPR	
def.....	28
T	
T_AST	
use.....	41
T_DLY_AD_i	
def.....	111
T_DLY_I_i	
def.....	111
T_DLY_P_i	
def.....	111
T_DLY_PUC_1	
use.....	93
T_DLY_PUC_2	
use.....	93
T_DLY_PUC_i	
def.....	116

Editor: Müller O.	17-Dec-97	Injection	HMC_V6
Version: a 153589 from 18.12.97		657765.49.06	
File: CHAP_7.DOC	650H0000		Page 17 / 121

T_LAM_DLY_1	
use.....	93
T_LAM_DLY_2	
use.....	93
T_LAM_DLY_i	
def.....	111
T_LAM_DLY_NEG_1	
def.....	93
T_LAM_DLY_NEG_2	
def.....	93
T_LAM_DLY_POS_1	
def.....	93
T_LAM_DLY_POS_2	
def.....	93
TCO	
use.....	28, 31, 32, 40, 41, 43, 47, 51, 55, 64, 67, 70, 77, 81, 83, 103, 116
TCO_ST	
use.....	34, 38, 40, 43, 85
TEMP_MMV_SUB_CAT	
use.....	111, 119
TI_[CYL]	
use.....	37
TI_1	
use.....	28, 34
TI_2	
use.....	28, 34
TI_AD_ACT_i	
def.....	103
TI_AD_ADD_MMV_COR_i	
def.....	103
use.....	21
TI_AD_ADD_MMV_i	
def.....	103
TI_AD_ADD_MMV_REL_i	
def.....	103
use.....	70, 111
TI_AD_FAC_MMV_1	
use.....	97
TI_AD_FAC_MMV_2	
use.....	97
TI_AD_FAC_MMV_COR_i	
def.....	103
use.....	21
TI_AD_FAC_MMV_i	
def.....	103
use.....	70, 111
TI_ADD_DLY	
def.....	37
use.....	21
TI_ADD_REAC_SCC_[CYL]	
def.....	67
use.....	21
TI_AE	
def.....	61
use.....	21
TI_AS_[CYL]	
def.....	21

Editor:	Müller O.	17-Dec-97	Injection	HMC_V6
Version:	a 153589 from 18.12.97		657765.49.06	
File:	CHAP_7.DOC	650H0000		Page 18 / 121

Proprietary data, company confidential. All rights reserved.
 Contient a titre de secret d'entreprise. Tous droits réservés.
 Comunicado como segredo empresarial. Reservados todos os direitos.
 Confidado como secreto industrial. Nos reservamos todos los derechos.

Weitergabe sowie Vervielfältigung dieser Unterlage, Verwertung und Mitteilung ihres Inhalts nicht gestattet, soweit nicht ausdrücklich zugestanden. Zuwiderhandlungen verpflichten zu Schadensersatz. Alle Rechte vorbehalten, insbesondere für den Fall der Patenterteilung oder GM-Entragung

use.....	21
TI_CAST	
def.....	38
use.....	21
TI_CH	
def.....	41
TI_CO_IS	
use.....	21
TI_COP	
def.....	43
use.....	21
TI_CST	
def.....	34
use.....	21
TI_CYL_[CYL]	
def.....	21
TI_FAC_ALTI	
def.....	60
use.....	21
TI_FAC_COR	
def.....	21
use.....	43
TI_FL	
def.....	46
use.....	21
TI_i	
def.....	21
TI_IS	
def.....	59
use.....	21
TI_LAM_1	
def.....	93
use.....	99
TI_LAM_2	
def.....	93
use.....	99
TI_LAM_i	
use.....	21, 70, 77, 83, 85, 103, 111
TI_LAM_MAX_1	
def.....	97
TI_LAM_MAX_2	
def.....	97
TI_LAM_MAX_i	
use.....	111
TI_LAM_MIN_1	
def.....	97
TI_LAM_MIN_2	
def.....	97
TI_LAM_MIN_i	
use.....	111
TI_MAF_AE	
def.....	51
use.....	21, 61
TI_MV	
def.....	21
use.....	28
TI_PUR	

Editor: Müller O.	17-Dec-97	Injection	HMC_V6
Version: a 153589 from 18.12.97		657765.49.06	
File: CHAP_7.DOC	650H0000		Page 19 / 121

Proprietary data, company confidential. All rights reserved.
 Contient des données confidentielles de l'entreprise. Tous droits réservés.
 Comunicado como secreto empresarial. Reservados todos los derechos.
 Confidado como secreto industrial. Nos reservamos todos los derechos.

Weitergabe sowie Vervielfältigung dieser Unterlage, Wertung und Mitteilung ihres Inhalts nicht gestattet, soweit nicht ausdrücklich zugestanden. Zuwiderhandlungen verpflichten zu Schadensersatz. Alle Rechte vorbehalten, insbesondere für den Fall der Patenterteilung oder GM-Enttragung

def.....	55
use.....	21
TI_SAM	
def.....	21
TI_ST_REST	
def.....	31
use.....	21
TI_TPS_AE	
def.....	47
use.....	21, 61
TI_WUP	
def.....	40
TI_WUP_COR	
use.....	21
TIA	
use.....	38, 103
TIA_ST	
use.....	85
TIB	
def.....	36
use.....	21, 67, 103
TIPR	
def.....	21
use.....	28
TIPR_CST	
def.....	32
use.....	21
TPS	
use.....	51
TPS_GRD	
use.....	47, 51
V	
VB	
use.....	37, 85, 119
VLS_AFL_i	
def.....	81
VLS_AFR_i	
def.....	81
VLS_BOL_i	
def.....	77
VLS_CAT_i	
use.....	111, 116
VLS_DIF_DLY_i	
def.....	111
VLS_DIF_i	
def.....	85
VLS_i	
use.....	77, 81
VLS_MMV_MAX_i	
def.....	77
use.....	81, 85
VLS_MMV_MIN_i	
def.....	77
use.....	81, 85
VLS_TOL_i	
def.....	77

Editor: Müller O.	17-Dec-97	Injection	HMC_V6
Version: a 153589 from 18.12.97		657765.49.06	
File: CHAP_7.DOC	650H0000		Page 20 / 121

1.1 General

1.1.1 Total formulas

Output data:

Name	Mode	Hex. limits	Phys. limits	Resol.	Unit
TIPR	V	0...FFFFH	0...262,14	4 µsec	msec
Pre injection time calculation.					
TI_i	V	0...FFFFH	0...262,14	4 µsec	msec
Injection time calculation for bank i (i = 1 or 2)					
TI_CYL_[CYL]	V	0...FFFFH	0...262,14	4 µsec	msec
Cylinder individual injection time calculation (i = 1,2,3,4,5,6)					
TI_SAM	V	0...FFFFH	0...262,14	4 µsec	msec
Multiplexed cylinder individual injection time calculation					
TI_AS_[CYL]	V	40...C0H	0,5...1,5	0,0078	-
Cylinder individual multiplicative factor set via application system (i = 1,2,3,4,5,6)					
TI_MV	V	0...FFFFH	0...262,14	4 µsec	msec
Injection time mean value for injection phase determination.					
TI_FAC_COR	-	0...FFFFH	0...16	0,000245	-
Global injection time correction factor.					

Input data:

TIPR_CST	IP_TI_LGRD_AST_TCO	TI_AD_ADD_MMV_COR_i	TI_AD_FAC_MMV_COR_i
TI_PUR	TI_CAST	TI_LAM_i	C_TI_AD_ADD_MAX
TI_FL	TI_IS	TI_CO_IS	C_TI_N_AD_ADD_MAX(A T)
TI_AE	TI_TPS_AE	TI_MAF_AE	N
TI_COP	TI_CST	TI_ADD_DLY	TIB
LV_ES	LV_ST	LV_PL	LV_IS
LV_TI_AST	LV_COP	LV_VS_MAX	C_TI_COP_COR
TI_WUP_COR	TI_ST_REST	LAM_TRA	C_TI_VS_MAX_COR
TI_ADD_REAC_SCC_[CYL]	TI_FAC_ALTI	TI_AS_[CYL]	CONF_LAM

Remark :

i = 1 for bank 1.
i = 2 for bank 2.

Editor: Müller O.	17-Dec-97	Injection	HMC_V6
Version: a 153589 from 18.12.97		657765.49.06	
File: CHAP_7.DOC	650H0000	Sourcefile:07700101.00H	Page 21 / 121

Proprietary data, company confidential. All rights reserved.
 Contit a titre de secret d'entreprise. Tous droits réservés.
 Comunicado como segredo empresarial. Reservados todos os direitos.
 Confidado como secreto industrial. Nos reservamos todos los derechos.

1.1.1.1 Cranking injection time

1.1.1.1.1 First injection at engine stopped (LV_ES)

$$\begin{aligned}
 \text{TIPR} = & (\text{TIPR_CST} && \text{Pre injection time.} \\
 & * \text{TI_ST_REST} && \text{Restart correction factor} \\
 & * \text{TI_AS_}[1]) && \text{Application system} \\
 & && \text{intervention cylinder 1.} \\
 & * \text{TI_FAC_ALTI} && \text{Altitude correction}
 \end{aligned}$$

Application recurrence : **200 msec**

1.1.1.1.2 Injection time at start (LV_ST)

$$\begin{aligned}
 \text{TI}_i = & (\text{TI_CST} && \text{Cranking injection time.} \\
 & * \text{TI_ST_REST}) && \text{Re-start correction factor.} \\
 & * \text{TI_FAC_ALTI} && \text{Altitude correction}
 \end{aligned}$$

Application recurrence : **Segment**

Weitergabe sowie Vervielfältigung dieser Unterlage, Verwertung und Mitteilung ihres Inhalts nicht gestattet, soweit nicht ausdrücklich zugestanden. Zuwiderhandlungen verpflichten zu Schadensersatz. Alle Rechte vorbehalten, insbesondere für den Fall der Patenterteilung oder GM-Entragung

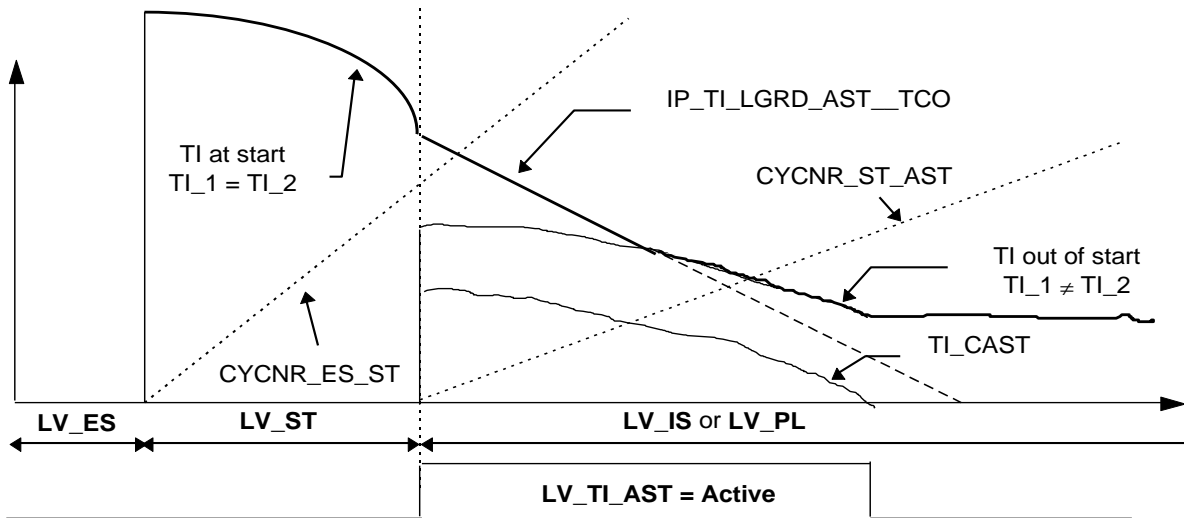

Editor: Müller O.	17-Dec-97	Injection	HMC_V6
Version: a 153589 from 18.12.97		657765.49.06	
File: CHAP_7.DOC	650H0000	Sourcefile:07700101.00H	Page 22 / 121

1.1.1.2 Nominal injection time (out of start)

1.1.1.2.1 Closed loop variant

If CONF_LAM ≠ 0
then

TI _i	=	[TIB	Basic injection time.
*	(1 + TI_AD_FAC_MMV_COR _i	Multiplicative adaptive correction
	+	TI_LAM _i	Lambda control correction.
	+	LAM_TRA)	Evaporative emissions control.
	+	TI_AD_ADD_MMV_COR _i]	Adaptive additive correction.
*		TI_FAC_COR	Global correction factor.

Application recurrence : **Segment**

⇒ See drawing on next page.

With:

$$TI_AD_ADD_MMV_COR_1 = C_TI_N_AD_ADD_MAX * TI_CO_IS / N$$

TI_AD_ADD_MMV_COR_1 is limited to C_TI_AD_ADD_MAX.

Remark:

The minimum injection time for TI_i is equal to C_TI_MIN.

Proprietary data, company confidential. All rights reserved.
 Contient des données confidentielles de la société. Tous droits réservés.
 Comunicado como segredo empresarial. Reservados todos os direitos.
 Confidado como secreto industrial. Nos reservamos todos los derechos.

Weitergabe sowie Vervielfältigung dieser Unterlage, Verwertung und Mitteilung ihres Inhalts ist gestattet, soweit nicht ausdrücklich zugestanden. Zuwiderhandlungen verpflichten zu Schadensersatz. Alle Rechte vorbehalten, insbesondere für den Fall der Patenterteilung oder GM-Entragung.

Editor: Müller O.	17-Dec-97	Injection	HMC_V6
Version: a 153589 from 18.12.97		657765.49.06	
File: CHAP_7.DOC	650H0000	Sourcefile:07700101.00H	Page 23 / 121

Proprietary data, company confidential. All rights reserved.
 Contient des informations confidentielles. Tous droits réservés.
 Comunicado como segredo empresarial. Reservados todos os direitos.
 Confidado como secreto industrial. Nos reservamos todos los derechos.

Weitergabe sowie Vervielfältigung dieser Unterlage, Verwertung und Mitteilung ihres Inhalts nicht gestattet, soweit nicht ausdrücklich zugestanden. Zuwiderhandlungen verpflichten zu Schadensersatz. Alle Rechte vorbehalten, insbesondere für den Fall der Patenterteilung oder GM-Entragung.

Basic injection time

Corrections:

Adaptive correction - multiplicative term

Lambda control correction

Evaporative emission control

Adaptive correction - additive term

Warm up correction
 or
 Catalyst heating correction
 or
 Secondary air warm-up correction

After-start correction

Idle speed correction

Full load enrichment
 Acceleration enrichment
 Catalyst overheating prevention

Trailing throttle fuel reduction correction

Restart fuel feed correction

Application system intervention

Calculated TI - Shown on SAM2000

Injector dead time correction

Final TI

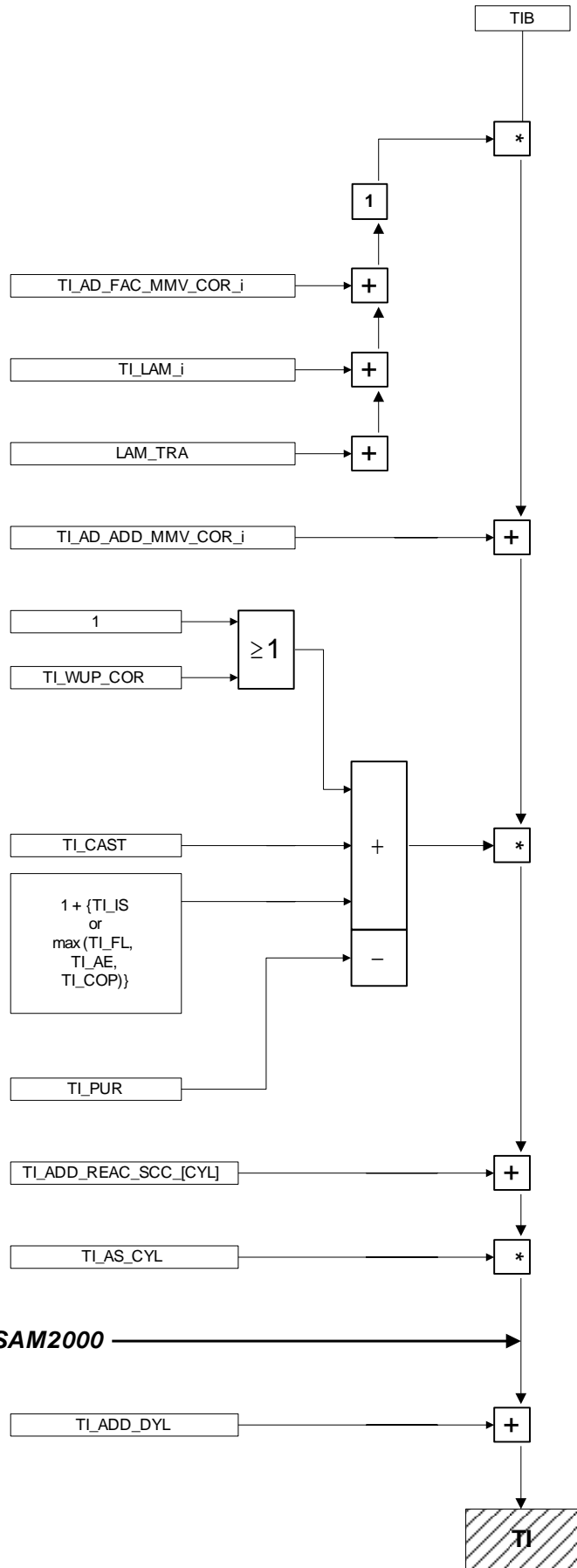

Editor: Müller O.	17-Dec-97	Injection	HMC_V6
Version: a 153589 from 18.12.97		657765.49.06	
File: CHAP_7.DOC	650H0000	Sourcefile:07700101.00H	Page 24 / 121

1.1.1.2.2 Open loop variant

If CONF_LAM = 0
then

$$\begin{aligned}
 TI_i = & [(TIB \quad \text{Basic injection time.} \\
 & * (1 - (IP_TI_NOT_CAT_N_MAF * IP_TI_FAC_NOT_CAT_TCO)) \quad \text{Correction for fuel leaning} \\
 & + TI_AD_ADD_MMV_COR_1] \quad \text{Multiplicative adaptive correction} \\
 & * TI_FAC_COR \quad \text{Global correction factor.}
 \end{aligned}$$

Application recurrence : **Segment**

With:

$$TI_AD_ADD_MMV_COR_1 = C_TI_N_AD_ADD_MAX * TI_CO_IS / N$$

TI_AD_ADD_MMV_COR_1 is limited to C_TI_AD_ADD_MAX.

Remark:

The minimum injection time for TI_i is equal to C_TI_MIN.

Proprietary data, company confidential. All rights reserved. Contient a titre de secret d'entreprise. Tous droits réservés. Comunicado como secreto empresarial. Reservados todos os direitos. Confidado como secreto industrial. Nos reservamos todos los derechos.

Weitergabe sowie Vervielfältigung dieser Unterlage, Wertung und Mitteilung ihres Inhalts nicht gestattet, soweit nicht ausdrücklich zugestanden. Zuwiderhandlungen verpflichten zu Schadensersatz. Alle Rechte vorbehalten, insbesondere für den Fall der Patenterteilung oder GM-Entragung.

Editor:	Müller O.	17-Dec-97	Injection	HMC_V6
Version:	a 153589 from 18.12.97		657765.49.06	
File:	CHAP_7.DOC	650H0000	Sourcefile:07700101.00H	Page 25 / 121

1.1.1.2.3 Global injection time correction (TI_FAC_COR)

Proprietary data, company confidential. All rights reserved. Contine a titre de secret d'entreprise. Tous droits réservés. Comunicado como segredo empresarial. Reservados todos os direitos. Confidado como secreto industrial. Nos reservamos todos los derechos.

Weitergabe sowie Vervielfältigung dieser Unterlage, Wertung und Mitteilung ihres Inhalts nicht gestattet, soweit nicht ausdrücklich zugestanden. Zuwiderhandlungen verpflichten zu Schadensersatz. Alle Rechte vorbehalten, insbesondere für den Fall der Patenterteilung oder GM-Entragung.

If LV_COP = 1 (*catalyst overheating prevention active*)
and at least 1 cylinder in fuel shut-off
then

If LV_VS_MAX = 0 (*vehicle speed limitation not active*)

then TI_FAC_COR = (1 - C_TI_COP_COR)
else TI_FAC_COR = [1 - max (C_TI_COP_COR, C_TI_VS_MAX_COR)]

else
If LV_VS_MAX = 1 (*vehicle speed limitation active*)
then TI_FAC_COR = (1 - C_TI_VS_MAX_COR)
else

If at least 1 cylinder in fuel shut-off
then TI_FAC_COR = 1
else the following calculation is performed :

TI_FAC_COR =	TI_WUP_COR	Warm-up correction or Catalyst heating correction or Rich Mixture Warm-up correction
	+	TI_CAST Post-start correction.
	-	TI_PUR Trailing throttle fuel reduction correction.
	+	{ 1 + [TI_IS Idle speed correction.
	or	
	max	(TI_FL, Full load enrichment. TI_AE, Acceleration enrichment. TI_COP) } Catalyst overheating prevention.

Application recurrence : **Segment**

Remarks :

TI_AE = TI_TPS_AE	Transient correction on throttle variations.
+ TI_MAF_AE	Transient correction on engine load variations.

Editor: Müller O.	17-Dec-97	Injection	HMC_V6
Version: a 153589 from 18.12.97		657765.49.06	
File: CHAP_7.DOC	650H0000	Sourcefile:07700101.00H	Page 26 / 121

Proprietary data, company confidential. All rights reserved.
 Contit a titre de secret d'entreprise. Tous droits réservés.
 Comunicado como secreto empresarial. Reservados todos os direitos.
 Confidado como secreto industrial. Nos reservamos todos los derechos.

Weitergabe sowie Vervielfältigung dieser Unterlage, Verwertung und Mitteilung ihres Inhalts nicht gestattet, soweit nicht ausdrücklich zugestanden. Zuwiderhandlungen verpflichten zu Schadensersatz. Alle Rechte vorbehalten, insbesondere für den Fall der Patenterteilung oder GM-Entragung.

1.1.1.3 Injection time mean value for injection phase determination (TI_MV)

$$TI_MV = (TI_1 + TI_2) / 2 + TI_ADD_DLY$$

Application recurrence : **Segment**

1.1.1.4 Cylinder individual injection time

TI_CYL_[CYL] takes in account the cylinder individual corrections:

$$TI_CYL_ [CYL] = (TI_i + TI_ADD_REAC_SCC_ [CYL]) * TI_AS_ [CYL]$$

TI_AS_[CYL] is a cylinder individual factor set via the application system.

Remark :

[CYL] = cylinder number
 i = cylinder bank number

Depending on the cylinder number, i is equal to 1 or 2.

1.1.1.5 Multiplexed cylinder individual injection time

TI_SAM takes alternatively the value TI_CYL_[CYL] depending on the cycle number.

Calibration data:

Name	Dim	Hex. limits	Phys. limits	Resol.	Unit
C_TI_MIN	1	0...FFFFH	0...262,14	4 µsec	msec
Minimum injection time.					
IP_TI_FAC_NOT_CAT__TCO	16x16	0... FFH	0...0,9961	1/256	-
Injection time correction for open loop variant					
IP_TI_NOT_CAT__N_32__MAF	6x6	0... FFFH	0...1	2,44 E-4	-
Injection time correction for open loop variant					

Editor: Müller O.	17-Dec-97	Injection	HMC_V6
Version: a 153589 from 18.12.97		657765.49.06	
File: CHAP_7.DOC	650H0000	Sourcefile:07700101.00H	Page 27 / 121

1.1.2 Injection phase SOI (Start), EOI (End)

Output data:

Name	Mode	Hex. limits	Phys. limits	Resol.	Unit
SOI	V	00...64H	180...-420	6	° CRK
Start of nominal injection time.					
EOI	V	14...3CH	-300...-540	6	° CRK
End of nominal injection time.					
SOI_TIPR	V	00...64H	180...-420	6	° CRK
Start of first injection					
EOI_TIPR	V	0...28H	-540...-300	6	° CRK
End of first injection time.					
LV_TIPR_SEQ	-	0...1H	0...1	1	-
Boolean information for first injection time: sequential after synchronisation (yes/no)					
LV_TIPR_EOI_STOP	-	0...1H	0...1	1	-
Boolean information for first injection time termination at NC_MAX_EOI					

Input data:

TI_MV	N_32	TCO	LV_CRK_ERR_LIH
LV_ST	TI_1	TI_2	TIPR
SOI_AS			

FUNCTION DESCRIPTION:

General information:

In order to optimize engine emissions and performances, the injection phase is related to the engine operating state and to the engine working point. With the pre-injection a spontaneous engine start is ensured because A/F-mixture is offered as early as possible. But at very low start temperatures the undefined position of the first injection can lead to problems. Because of this the first injections are carried out sequential below the temperature C_TCO_MAX_TIPR_SEQ.

With the configuration byte C_TIPR_END it can be adjusted wether a pre-injection will be terminated at NC_MAX_EOI or not.

For graphical description of the first injection please refer to the output chapter.

Formula section:

* Start of injection :

* *Start injection time (LV_ST = 1) :*

$$SOI = IP_SOI_ST_N_32_TI_MV + SOI_AS$$

Editor: Müller O.	17-Dec-97	Injection	HMC_V6
Version: a 153589 from 18.12.97		657765.49.06	
File: CHAP_7.DOC	650H0000	Sourcefile:07700201.00E	Page 28 / 121

Proprietary data, company confidential. All rights reserved. Contine a titre de secret d'entreprise. Tous droits réservés. Comunicado como segredo empresarial. Reservados todos os direitos. Confidado como secreto industrial. Nos reservamos todos los derechos.

Weitergabe sowie Vervielfältigung dieser Unterlage, Verwertung und Mitteilung ihres Inhalts nicht gestattet, soweit nicht ausdrücklich zugestanden. Zuwiderhandlungen verpflichten zu Schadensersatz. Alle Rechte vorbehalten, insbesondere für den Fall der Patenterteilung oder GM-Entragung.

* *First injection configuration :*

Application recurrency: Transition to engine stop (LV_ES = 1)

```

if    C_TIPR_END = 0
then  LV_TIPR_EOI_STOP = 0
        (First injection time will not be terminated at NC_MAX_EOI during
        synchronisation)
else  LV_TIPR_EOI_STOP = 1
  
```

```

if    C_TCO_MAX_TIPR_SEQ ≥ TCO
then  LV_TIPR_SEQ = 1
        (First injection will be carried out sequential after synchronisation)
else  LV_TIPR_SEQ = 0
        (TIPR is carried out in semi full group)
  
```

* *Nominal injection time (out of start) :*

- for injection time TI_i out of start

```

if    LV_CRK_ERR_LIH = 1
        (camshaft signal missing - refer to "Diagnosis Management ")
then  SOI = C_SOI_CAM_DIAG
else  SOI = IP_SOI_N_32_TI_MV + IP_SOI_TCO_TCO + SOI_AS
  
```

* *First injection time (TIPR) :*

SOI_TIPR = IP_SOI_ST_N_32_TI_MV + SOI_AS
with N_32 = 0 and TI_MV = TIPR

* End of injection :* *Nominal injection time :*

- for injection time TI_i

```

if    LV_CRK_ERR_LIH = 1
        (camshaft signal missing - refer to "Diagnosis Management ")
        or    engine operating state start (LV_ST)
        or    N_32 > C_EOI_N_MAX
then  EOI = NC_MAX_EOI
else  EOI = IP_EOI_N_32 + SOI_AS
  
```

* *First injection time :*

EOI_TIPR = IP_EOI_TIPR_TCO

Editor:	Müller O.	17-Dec-97	Injection	HMC_V6
Version:	a 153589 from 18.12.97		657765.49.06	
File:	CHAP_7.DOC	650H0000	Sourcefile:07700201.00E	Page 29 / 121

Calibration data:

Name	Dim	Hex. limits	Phys. limits	Resol.	Unit
IP_SOI_ST_N_32_TI_MV	4 x 4	00...64H	180...-420	6	° CRK
Start of injection phase at start for nominal injection time TI_i.					
IP_SOI_N_32_TI_MV	6 x 6	00...64H	180...-420	6	° CRK
Start of injection phase out of start for nominal injection time TI_i.					
IP_SOI_TCO_TCO	8	1C...E4H	600...-600	6	° CRK
Start of injection phase offset versus coolant temperature, out of start for nominal injection time TI_i.					
IP_EOI_N_32	6	14...3CH	-300...-540	6	° CRK
End of injection phase for nominal injection time TI_i.					
C_SOI_CAM_DIAG	1	00...64H	180...-420	6	° CRK
Start of injection phase out of start for nominal injection time TI_i with camshaft signal missing.					
C_EOI_N_MAX	1	00...FFH	0..8160	32	rpm
Engine speed threshold to select maximum EOI (NC_MAX_EOI).					
NC_MAX_EOI	1	14...3CH	-300...-540	6	° CRK
Maximum end of injection phase - Non adjustable calibration.					
IP_EOI_TIPR	8	00...28H	-540...-300	6	° CRK
End of injection phase for first injection					
C_TIPR_END	1	0...1H	0..1	1	-
Configuration byte for TIPR-termination at NC_MAX_EOI - position					
C_TCO_MAX_TIPR_SEQ	1	0...FEH	-48...142,5	0,75	° C
Maximum coolant temperatur for sequential TIPR-application					

Applicative Value :

NC_MAX_EOI = 3CH = -540 °CRK

Proprietary data, company confidential. All rights reserved. Contient des données confidentielles de la société. Tous droits réservés. Comunicado como secreto empresarial. Reservados todos os direitos. Confidado como secreto industrial. Nos reservamos todos los derechos.

Weitergabe sowie Vervielfältigung dieser Unterlage, Verbreitung und Mitteilung ihres Inhalts nicht gestattet, soweit nicht ausdrücklich zugestanden. Zuwiderhandlungen verpflichten zu Schadenersatz. Alle Rechte vorbehalten, insbesondere für den Fall der Patenterteilung oder GM-Entragung.

Editor: Müller O.	17-Dec-97	Injection	HMC_V6
Version: a 153589 from 18.12.97		657765.49.06	
File: CHAP_7.DOC	650H0000	Sourcefile:07700201.00E	Page 30 / 121

1.1.3 Re-start correction factor (TI_ST_REST)

Output data:

Name	Mode	Hex. limits	Phys. limits	Resol.	Unit
TI_ST_REST	-	80...FFH	0,5...0,9961	0,0039	-
Re-start correction factor for cranking injection time.					

Input data:

TCO	LV_REST		
-----	---------	--	--

FUNCTION DESCRIPTION:

General information:

In order to improve engine re-start, a correction factor is applied for cranking injection time calculation (pre injection time and injection time at start). This factor is multiplicative and decreases the injection time.

Formula section:

If LV_REST = 1 (Active) *(re-start function active)*

then TI_ST_REST = IP_TI_ST_REST__TCO

If LV_REST = 0 (Passive) *(re-start function passive)*

then TI_ST_REST = 1

Calibration data:

Name	Dim	Hex. limits	Phys. limits	Resol.	Unit
IP_TI_ST_REST__TCO	8	80...FFH	0,5...0,9961	0,0039	-
Re-start correction factor for cranking injection time.					

Proprietary data, company confidential. All rights reserved. Contine a titre de secret d'entreprise. Tous droits réservés. Comunicado como segredo empresarial. Reservados todos os direitos. Confidado como secreto industrial. Nos reservamos todos los derechos.

Weitergabe sowie Vervielfältigung dieser Unterlage, Wertung und Mitteilung ihres Inhalts nicht gestattet, soweit nicht ausdrücklich zugestanden. Zuwiderhandlungen verpflichten zu Schadenersatz. Alle Rechte vorbehalten, insbesondere für den Fall der Patenterteilung oder GM-Entragung.

Editor: Müller O.	17-Dec-97	Injection	HMC_V6
Version: a 153589 from 18.12.97		657765.49.06	
File: CHAP_7.DOC	650H0000	Sourcefile:07700301.00C	Page 31 / 121

Proprietary data, company confidential. All rights reserved. Contient des informations confidentielles. Tous droits réservés. Comunicado como segredo empresarial. Reservados todos os direitos. Confidado como secreto industrial. Nos reservamos todos los derechos.

Weitergabe sowie Vervielfältigung dieser Unterlage, Verwertung und Mitteilung ihres Inhalts nicht gestattet, soweit nicht ausdrücklich zugestanden. Zuwiderhandlungen verpflichten zu Schadenersatz. Alle Rechte vorbehalten, insbesondere für den Fall der Patenterteilung oder GM-Entragung.

1.2 Calculation of injection time corrections

1.2.1 Calculation of cranking injection time corrections

1.2.1.1 First injection time (TIPR_CST)

Output data:

Name	Mode	Hex. limits	Phys. limits	Resol.	Unit
TIPR_CST	-	0...FFFFH	0...262,14	4 µsec	msec
Pre injection time basic value.					

Input data:

LV_ES	LV_ST	TCO	LV_ST_ES
MAF_FAC_ALTI_MMV			

FUNCTION DESCRIPTION:

General information:

In order to improve engine cranking times, a pre injection takes place on each cylinder bank as soon as one tooth is detected.

(refer to chapter " Fuel injection output " in the major chapter " Outputs ")

Formula section:

$$TIPR_CST = IP_TIPR_CST(_AT)_TCO$$

In case of transition from start (LV_ST) to engine stopped (LV_ES) and therefore LV_ST_ES=1, the next pre injection time will be weighted by a multiplicative factor :

If LV_ST_ES = 1
then TIPR_CST = IP_TIPR_CST(_AT)_TCO * IP_TIPR_FAC_ST_ES_TCO

The pre-injection is corrected with the altitude correction factor MAF_FAC_ALTI_MMV. For total formula see chapter 1.1.1.1.2.

Editor: Müller O.	17-Dec-97	Injection	HMC_V6
Version: a 153589 from 18.12.97		657765.49.06	
File: CHAP_7.DOC	650H0000	Sourcefile:07700401.00F	Page 32 / 121

Calibration data:

Name	Dim	Hex. limits	Phys. limits	Resol.	Unit
IP_TIPR_CST(_AT)__TCO	8	0...FFFFH	0...262,14	4 µsec	msec
Pre injection time basic value.					
IP_TIPR_FAC_ST_ES(_AT)__TCO	8	80...FFH	0,5...0,9961	0,0039	-
Weighting factor of pre injection time basic value in case of transition from LV_ST to LV_ES.					
IP_TI_FAC_ALTI__MAF_FAC_ALTI_MMV	8	80...FFH	0,5...0,9961	0,0039	-
Weighting factor of pre injection time basic value due to altitude correction.					

Proprietary data, company confidential. All rights reserved.
 Contient des données confidentielles de la société. Tous droits réservés.
 Comunicado como secreto empresarial. Reservados todos los derechos.
 Confiado como secreto industrial. Nos reservamos todos los derechos.

Weitergabe sowie Vervielfältigung dieser Unterlage, Verwertung und Mitteilung ihres Inhalts nicht gestattet, soweit nicht ausdrücklich zugestanden. Zuwiderhandlungen verpflichten zu Schadensersatz. Alle Rechte vorbehalten, insbesondere für den Fall der Patenterteilung oder GM-Enttragung.

Editor: Müller O.	17-Dec-97	Injection	HMC_V6
Version: a 153589 from 18.12.97		657765.49.06	
File: CHAP_7.DOC	650H0000	Sourcefile:07700401.00F	Page 33 / 121

1.2.1.2 Injection time at start (TI_CST)

Output data:

Name	Mode	Hex. limits	Phys. limits	Resol.	Unit
TI_CST	-	0...FFFFH	0...262,14	4 µsec	msec
Cranking injection time basic value.					

Input data:

LV_ES	LV_ST	TCO_ST	LV_SYN_ENG
LV_TI_AST	N	TI_1	TI_2
CYCNR_ES_ST			

FUNCTION DESCRIPTION:

General information:

As soon as synchronisation is fulfilled in engine operating state start (LV_ST), each cylinder is supplied with a specific fuel quantity for starting. This quantity is weighted by a de-activation factor in order to avoid engine flooding.

Formula section:

If engine operating state start (LV_ST)
and LV_SYN_ENG = 1 (*synchronisation effective*)
then

$TI_CST = IP_TI_CST(_AT)_N_TCO_ST * IP_TI_DEAC_CST(_AT)_CYCNR_ES_ST_TCO_ST$

Remark :

- * CYCNR_ES_ST indicates the number of segments since engine stop; it is reset at transition from LV_ES to LV_ST.
- * The start fuel quantity (LV_ST) returned to the post - start fuel quantity (LV_TI_AST) is performed using change limitation IP_TI_LGRD_AST_TCO
 Like cranking injection time TI_i is identical for bank 1 & 2 during engine operating state start (LV_ST), the change limitation IP_TI_LGRD_AST_TCO is applied as " individual " correction for TI_i during post-start function (LV_TI_AST) because TI_1 ≠ TI_2.

Proprietary data, company confidential. All rights reserved. Contine a titre de secret d'entreprise. Tous droits réservés. Comunicado como segredo empresarial. Reservados todos os direitos. Confidado como secreto industrial. Nos reservamos todos los derechos.

Weitergabe sowie Vervielfältigung dieser Unterlage, Wertung und Mitteilung ihres Inhalts nicht gestattet, soweit nicht ausdrücklich zugestanden. Zuwiderhandlungen verpflichten zu Schadensersatz. Alle Rechte vorbehalten, insbesondere für den Fall der Patenterteilung oder GM-Entragung.

- * For case 1 of the restart strategy the CYCNR_ES_ST counter will start with the old value freezed at the previous transition LV_ST to LV_ES. _

The injection time at start is corrected with the altitude correction factor MAF_FAC_ALTI_MMV. For total formula see chapter 1.1.1.1.2.

Calibration data:

Name	Dim	Hex. limits	Phys. limits	Resol.	Unit
IP_TI_CST(AT)_N_TCO_ST	5 x 8	0...FFFFH	0...262,14	4 µsec	msec
Cranking injection time basic value.					
IP_TI_DEAC_CST(AT)_CYCNR_ES_ST_TCO_ST	4 x 6	00...FFH	0...0,997	3,895E-3	-
Cranking injection time deactivation factor.					
IP_TI_LGRD_AST_TCO	8	08...07F8H	0,0427...10,88	0,00533	msec
Change limitation between cranking injection time and nominal injection time (x Segment).					

Proprietary data, company confidential. All rights reserved. Contine a titre de secret d'entreprise. Tous droits réservés. Comunicado como segredo empresarial. Reservados todos os direitos. Confidado como secreto industrial. Nos reservamos todos los derechos.

Weitergabe sowie Vervielfältigung dieser Unterlage, Verwertung und Mitteilung ihres Inhalts nicht gestattet, soweit nicht ausdrücklich zugestanden. Zuwiderhandlungen verpflichten zu Schadensersatz. Alle Rechte vorbehalten, insbesondere für den Fall der Patenterteilung oder GM-Eintragung.

Editor: Müller O.	17-Dec-97	Injection	HMC_V6
Version: a 153589 from 18.12.97		657765.49.06	
File: CHAP_7.DOC	650H0000	Sourcefile:07700501.00H	Page 35 / 121

1.2.2 Calculation of nominal injection time corrections

1.2.2.1 Basic injection time (TIB)

Output data:

Name	Mode	Hex. limits	Phys. limits	Resol.	Unit
TIB	-	0...FFFFH	0...262,14	4 µsec	msec
Basic injection time.					

Input data:

LV_ES	LV_ST	N_32	MAF
-------	-------	------	-----

FUNCTION DESCRIPTION:

General information:

The basic injection time is depending on engine working point (N_32, MAF).
It is applied for nominal injection time calculation TI_i out of engine stopped (LV_ES) and out of start (LV_ST).

Application recurrence : **Segment**

Formula section:

$$TIB = IP_TIB_N_MAF$$

Calibration data:

Name	Dim	Hex. limits	Phys. limits	Resol.	Unit
IP_TIB_N_MAF	16 x 12	0F...FFFFH	0...262,14	4 µsec	msec
Basic injection time.					

Proprietary data, company confidential. All rights reserved.
 Contient des données confidentielles de la société. Tous droits réservés.
 Comunicado como segredo empresarial. Reservados todos os direitos.
 Confidado como secreto industrial. Nos reservamos todos los derechos.

Weitergabe sowie Vervielfältigung dieser Unterlage, Verbreitung und Mitteilung ihres Inhalts nicht gestattet, soweit nicht ausdrücklich zugestanden. Zuwiderhandlungen verpflichten zu Schadensersatz. Alle Rechte vorbehalten, insbesondere für den Fall der Patenterteilung oder GM-Entragung.

Editor: Müller O.	17-Dec-97	Injection	HMC_V6
Version: a 153589 from 18.12.97		657765.49.06	
File: CHAP_7.DOC	650H0000	Sourcefile:07700601.00C	Page 36 / 121

1.2.3 Injector dead time correction (TI_ADD_DLY)

Output data:

Name	Mode	Hex. limits	Phys. limits	Resol.	Unit
TI_ADD_DLY	-	0...FFH	0...8,16	0,0032	msec
Injector dead time correction.					

Input data:

TI_[CYL]	VB		
----------	----	--	--

FUNCTION DESCRIPTION:

General information:

The injection time TI_[CYL] applied to the corresponding injector, is weighted by an additive correction TI_ADD_DLY in order to compensate the battery voltage dependent injector pick-up time.

(refer to chapter " Fuel injection output " in major chapter " Outputs ")

Application recurrence : **10 msec.**

Formula section:

$$TI_ADD_DLY = IP_TI_ADD_DLY_VB$$

Calibration data:

Name	Dim	Hex. limits	Phys. limits	Resol.	Unit
IP_TI_ADD_DLY_VB	8	0...FFH	0...8,16	0,032	msec
Injector dead time correction.					

Proprietary data, company confidential. All rights reserved. Contient a titre de secret d'entreprise. Tous droits réservés. Comunicado como segredo empresarial. Reservados todos os direitos. Confidado como secreto industrial. Nos reservamos todos los derechos.

Weitergabe sowie Vervielfältigung dieser Unterlage, Wertung und Mitteilung ihres Inhalts nicht gestattet, soweit nicht ausdrücklich zugestanden. Zuwiderhandlungen verpflichten zu Schadensersatz. Alle Rechte vorbehalten, insbesondere für den Fall der Patenterteilung oder GM-Entragung.

Editor: Müller O.	17-Dec-97	Injection	HMC_V6
Version: a 153589 from 18.12.97		657765.49.06	
File: CHAP_7.DOC	650H0000	Sourcefile:07700801.00C	Page 37 / 121

1.2.3.1 Cold post-start correction (TI_CAST)

Output data:

Name	Mode	Hex. limits	Phys. limits	Resol.	Unit
TI_CAST	V	0...3F40H	0...3.953	16 / 65536	-
Cold post-start correction.					

Input data:

LV_TI_AST	LV_ST	TCO_ST	TIA
CYCNR_ST_AST			

FUNCTION DESCRIPTION:

General information:

This enrichment is performed following engine operating start (LV_ST) in order to ensure the first combustion in cold conditions.

Application recurrence : **Segment**

Formula section:

If LV_TI_AST = 1 (Active) *(cold post-start function active)*
then

$TI_CAST = IP_TI_CAST(_AT)_TIA_TCO_ST * IP_TI_DEAC_CAST(_AT)_CYCNR_ST_AST_TCO_ST * IP_TI_AST_REST_TCO$
--

Remark :

- * CYCNR_ST_AST indicates the number of segments since start; it is reset at the transition LV_ST to LV_TI_AST.
- * The post-start fuel quantity is initialized with the value coming from the interpolated table IP_TI_CAST(_AT)_TIA_TCO_ST as soon as LV_TI_AST = 1 (Active). Then, this initialized value is deactivated by IP_TI_DEAC_CAST(_AT)_CYCNR_ST_AST_TCO_ST.
- * IP_TI_AST_REST_TCO is applied to the post-start correction in case of restart.

Editor: Müller O.	17-Dec-97	Injection	HMC_V6
Version: a 153589 from 18.12.97		657765.49.06	
File: CHAP_7.DOC	650H0000	Sourcefile:07700901.00H	Page 38 / 121

Proprietary data, company confidential. All rights reserved. Contine a titre de secret d'entreprise. Tous droits réservés. Comunicado como segredo empresarial. Reservados todos os direitos. Confidado como secreto industrial. Nos reservamos todos los derechos.

Weitergabe sowie Vervielfältigung dieser Unterlage, Verwertung und Mitteilung ihres Inhalts nicht gestattet, soweit nicht ausdrücklich zugestanden. Zuwiderhandlungen verpflichten zu Schadensersatz. Alle Rechte vorbehalten, insbesondere für den Fall der Patenterteilung oder GM-Entragung.

Calibration data:

Name	Dim	Hex. limits	Phys. limits	Resol.	Unit
IP_TI_CAST(_AT)__TIA__TCO_ST	6 x 8	0...FFH	0...3.984	0.0156	-
Initialized value for post-start enrichment factor.					
IP_TI_DEAC_CAST(_AT)__CYCNR_ST_AS T__TCO_ST	6 x 8	0...FFH	0...0.9961	0.0039	-
Post-start enrichment deactivation factor.					
IP_TI_AST_REST__TCO	8	80...FFH	0.5...0.9961	0.0039	-
Restart correction factor .					

Proprietary data, company confidential. All rights reserved.
 Contient des données confidentielles de l'entreprise. Tous droits réservés.
 Comunicado como secreto empresarial. Reservados todos los derechos.
 Confiado como secreto industrial. Nos reservamos todos los derechos.

Weitergabe sowie Vervielfältigung dieser Unterlage, Wertung und Mitteilung ihres Inhalts nicht gestattet, soweit nicht ausdrücklich zugestanden. Zuwiderhandlungen verpflichten zu Schadensersatz. Alle Rechte vorbehalten, insbesondere für den Fall der Patenterteilung oder GM-Entragung

Editor: Müller O.	17-Dec-97	Injection	HMC_V6
Version: a 153589 from 18.12.97		657765.49.06	
File: CHAP_7.DOC	650H0000	Sourcefile:07700901.00H	Page 39 / 121

1.2.3.2 Warm-up correction (TI_WUP)

Output data:

Name	Mode	Hex. limits	Phys. limits	Resol.	Unit
TI_WUP	-	1000...2FC0H	1...2,9844	16 / 65536	-
Warm-up correction for nominal injection time.					

Input data:

LV_SCC_TQR	N_32	MAF	TCO
TCO_ST			

FUNCTION DESCRIPTION:

General information:

The warm-up injection time correction is performed when the corresponding warm-up phase is detected in order to ensure the increased fuel requirements for a cold engine.

Application recurrence : **Segment**

Formula section:

If LV_SCC_TQR = 0 (Passive) *(no fuel shut-off active due to ASR or GS)*

then TI_WUP = 1 + IP_TI_WUP(_AT)__N_32__MAF
 * IP_TI_TCO_WUP(_AT)__TCO__TCO_ST

If LV_SCC_TQR = 1 (Active) *(fuel shut-off active due to ASR or GS)*

then TI_WUP = 1 + IP_TI_WUP(_AT)__N_32__MAF
 * IP_TI_TCO_WUP_ASR__TCO__TCO_ST

Remark: For further information about torque intervention and effects on the system please refer to the chapter „Traction Control System“.

Calibration data:

Name	Dim	Hex. limits	Phys. limits	Resol.	Unit
IP_TI_WUP(_AT)__N_32__MAF	8 x 8	0...FFH	0...0,9961	0,0039	-
Warm-up correction versus engine operating point.					
IP_TI_TCO_WUP(_AT)__TCO__TCO_ST	8 x 3	0...FFH	0...1,9922	0,00782	-
Warm-up deactivation factor without TQR intervention.					
IP_TI_TCO_WUP_ASR__TCO__TCO_ST	6 x 6	0...FFH	0...1,9922	0,00782	-
Warm-up deactivation factor with TQR intervention.					

Editor: Müller O.	17-Dec-97	Injection	HMC_V6
Version: a 153589 from 18.12.97		657765.49.06	
File: CHAP_7.DOC	650H0000	Sourcefile:07700A01.00E	Page 40 / 121

Proprietary data, company confidential. All rights reserved. Contine a titre de secret d'entreprise. Tous droits réservés. Comunicado como segredo empresarial. Reservados todos os direitos. Confidado como secreto industrial. Nos reservamos todos los derechos.

Weitergabe sowie Vervielfältigung dieser Unterlage, Wertung und Mitteilung ihres Inhalts nicht gestattet, soweit nicht ausdrücklich zugestanden. Zuwiderhandlungen verpflichten zu Schadensersatz. Alle Rechte vorbehalten, insbesondere für den Fall der Patenterteilung oder GM-Entragung.

1.2.3.3 Catalyst heating correction (TI_CH)

Output data:

Name	Mode	Hex. limits	Phys. limits	Resol.	Unit
TI_CH	-	0800...37C0 H	0,5...3,4844	16 / 65536	-
Catalyst heating correction for nominal injection time.					

Input data:

LV_IS	TCO	T_AST	N_32
MAF	LV_TI_CH	LV_MAF_ERR	

FUNCTION DESCRIPTION:

General information:

The catalyst heating correction for nominal injection time is performed when the corresponding warm-up phase is detected (LV_TI_CH = 1) in order to ensure a catalyst warm-up as quickly as possible and to operate the engine with low emissions.

This is an alternative to the warm-up function.

The engine can run with a lean mixture at high loads and engine speeds, even in cold engine conditions.

Application recurrence : **Segment**

Formula section:

This Function is performed if LV_MAF_ERR = 0.

* In idle (LV_IS) :

$$TI_CH = IP_TI_CH_N_32_MAF * IP_TI_TCO_CH_IS_TCO + IP_TI_FAC_CH_TCO_T_AST$$

* Out of idle :

$$TI_CH = IP_TI_CH_N_32_MAF * IP_TI_TCO_CH_TCO + IP_TI_FAC_CH_TCO_T_AST$$

Remark :

The transition from idle to out of idle calculation is made without change limitation.

Proprietary data, company confidential. All rights reserved. Contine a titre de secret d'entreprise. Tous droits réservés. Comunicado como segredo empresarial. Reservados todos os direitos. Confidado como secreto industrial. Nos reservamos todos los derechos.

Weitergabe sowie Vervielfältigung dieser Unterlage, Verwertung und Mitteilung ihres Inhalts nicht gestattet, soweit nicht ausdrücklich zugestanden. Zuwiderhandlungen verpflichten zu Schadensersatz. Alle Rechte vorbehalten, insbesondere für den Fall der Patenterteilung oder GM-Entragung.

Editor: Müller O.	17-Dec-97	Injection	HMC_V6
Version: a 153589 from 18.12.97		657765.49.06	
File: CHAP_7.DOC	650H0000	Sourcefile:07700B01.00E	Page 41 / 121

Calibration data:

Name	Dim	Hex. limits	Phys. limits	Resol.	Unit
IP_TI_CH_N_32_MAF	8 x 8	0...FFH	0...0,9961	0,0039	-
Catalyst heating correction for nominal injection time versus engine operating point.					
IP_TI_TCO_CH_TCO	8	00...FFH	0...1,922	7,509E-3	-
Catalyst heating correction for nominal injection time versus coolant temperature out of idle.					
IP_TI_TCO_CH_IS_TCO	8	00...FFH	0...1,922	7,509E-3	-
Catalyst heating correction for nominal injection time versus coolant temperature in idle (LV_IS).					
IP_TI_FAC_CH_TCO_T_AST	8 x 8	0800...1800H	0,5...1,5	16 / 65536	-
Minimum value of catalyst heating correction for nominal injection time.					

Proprietary data, company confidential. All rights reserved. Contine a titre de secret d'entreprise. Tous droits réservés. Comunicado como segredo empresarial. Reservados todos os direitos. Confidado como secreto industrial. Nos reservamos todos los derechos.

Weitergabe sowie Vervielfältigung dieser Unterlage, Wertung und Mitteilung ihres Inhalts nicht gestattet, soweit nicht ausdrücklich zugestanden. Zuwiderhandlungen verpflichten zu Schadensersatz. Alle Rechte vorbehalten, insbesondere für den Fall der Patenterteilung oder GM-Eintragung.

Editor: Müller O.	17-Dec-97	Injection	HMC_V6
Version: a 153589 from 18.12.97		657765.49.06	
File: CHAP_7.DOC	650H0000	Sourcefile:07700B01.00E	Page 42 / 121

1.2.3.4 Catalyst overheating prevention (TI_COP)

Output data:

Name	Mode	Hex. limits	Phys. limits	Resol.	Unit
TI_COP	V	0...FFH	0...0,5	0,00196	-
Injection time correction for catalyst overheating prevention.					
LV_COP	V	0...01H	0...1	1	-
Boolean for catalyst overheating prevention detection - (Passive / Active).					
IGA_COP	V	80...00H	-48...0	0,375	°CRK
Ignition angle correction used as set point for catalyst overheating correction.					

Input data:

TCO	N_32	MAF	TCO_ST
ID_TCO_LAM_MIN__TCO_ST	TI_FAC_COR	LV_LSCL_1	LV_LSCL_2
IGA_TIA_TCO	C_TI_VS_MAX_COR	LV_VS_MAX	IGA_MV_KNK

FUNCTION DESCRIPTION:

General information:

The catalyst overheating prevention function is provided in order to avoid an overheating phenomena in the catalyst. The emission temperatures drop through mixture enrichment. The injection time correction is calculated depending on engine operating point and ignition through knock control (IGA_MV_KNK) and temperature (IGA_TIA_TCO) corrections.

Application recurrence : **720 °CRK**

Application conditions:

Activation:

The injection time correction TI_COP proceeds over a ramp for activation. Thus, TI_COP is increased with C_TI_COP_INC every 720 °CRK.

If engine operating state in part load (LV_PL)
and TCO > ID_TCO_LAM_MIN__TCO_ST
and MAF ≥ IP_MAF_MIN_COP__N_32__IGA_COP
and IGA_COP ≤ C_IGA_MIN_COP
then LV_COP = 1 (Active)

Deactivation:

The injection time correction TI_COP proceeds over a ramp for deactivation. Thus, TI_COP is decreased with C_TI_COP_INC every 720 °CRK.

If MAF < IP_MAF_MIN_COP__N_32__IGA_COP - C_MAF_MIN_HYS_COP
or IGA_COP > C_IGA_MIN_COP
then LV_COP = 0 (Passive) as soon as TI_COP = 0.

Editor: Müller O.	17-Dec-97	Injection	HMC_V6
Version: a 153589 from 18.12.97		657765.49.06	
File: CHAP_7.DOC	650H0000	Sourcefile:07700C01.00D	Page 43 / 121

Proprietary data, company confidential. All rights reserved. Contine a titre de secret d'entreprise. Tous droits réservés. Comunicado como segredo empresarial. Reservados todos os direitos. Confidado como secreto industrial. Nos reservamos todos los derechos.

Weitergabe sowie Vervielfältigung dieser Unterlage, Verwertung und Mitteilung ihres Inhalts nicht gestattet, soweit nicht ausdrücklich zugestanden. Zuwiderhandlungen verpflichten zu Schadensersatz. Alle Rechte vorbehalten, insbesondere für den Fall der Patenterteilung oder GM-Entragung.

Proprietary data, company confidential. All rights reserved.
 Contit a titre de secret d'entreprise. Tous droits réservés.
 Comunicado como secreto empresarial. Reservados todos os direitos.
 Confidado como secreto industrial. Nos reservamos todos los derechos.

Remark :

If LV_COP = 1 (Active) (*catalyst overheating prevention active*)
and engine operating state engine stopped (LV_ES)
or engine operating state start (LV_ST)
or engine operating state fuel cut-off (LV_PUC)
then TI_COP is decreased to 0 without change limitation.

Limitation :

$$0 \leq TI_COP \leq 0.5$$

Formula section:

$$TI_COP = IP_TI_COP_N_32_MAF + IP_TI_COP_IGA_IGA_COP$$

with :

$$IGA_COP = IGA_MV_KNK + IGA_TIA_TCO$$

Remark :

The global correction factor calculation TI_FAC_COR for the nominal injection time out of start is depending of the catalyst overheating prevention function :

If LV_COP = 1 (Active) (*catalyst overheating prevention active*)
and at least 1 cylinder in fuel shut-off
then
 If LV_VS_MAX = 0 (Passive) (*vehicle speed limitation passive*)
 then TI_FAC_COR = (1 - C_TI_COP_COR)
 else TI_FAC_COR = [1 - max (C_TI_COP_COR, C_TI_VS_MAX_COR)]

In this engine operating configuration, TI_COP is still updated but not used for injection time calculation, until regular TI_FAC_COR calculation will be performed again.

Weitergabe sowie Vervielfältigung dieser Unterlage, Verwertung und Mitteilung ihres Inhalts nicht gestattet, soweit nicht ausdrücklich zugestanden. Zuwiderhandlungen verpflichten zu Schadensersatz. Alle Rechte vorbehalten, insbesondere für den Fall der Patenterteilung oder GM-Entragung.

Editor: Müller O.	17-Dec-97	Injection	HMC_V6
Version: a 153589 from 18.12.97		657765.49.06	
File: CHAP_7.DOC	650H0000	Sourcefile:07700C01.00D	Page 44 / 121

Description:

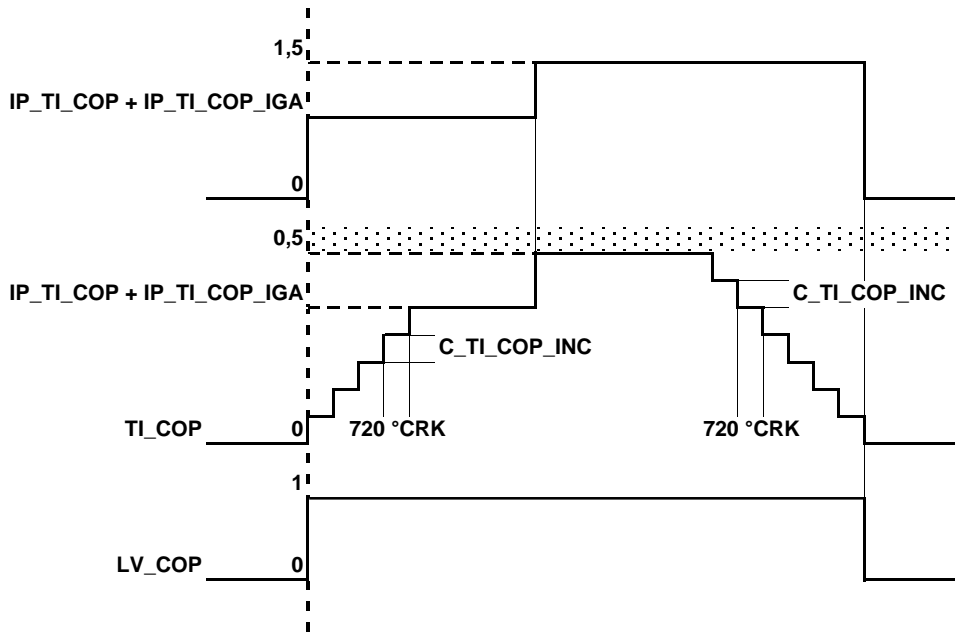

Proprietary data, company confidential. All rights reserved.
 Contine a titre de secret d'entreprise. Tous droits réservés.
 Comunicado como segredo empresarial. Reservados todos os direitos.
 Confidado como secreto industrial. Nos reservamos todos los derechos.

Weitergabe sowie Vervielfältigung dieser Unterlage, Verwertung und Mitteilung ihres Inhalts nicht gestattet, soweit nicht ausdrücklich zugestanden. Zuwiderhandlungen verpflichten zu Schadenersatz. Alle Rechte vorbehalten, insbesondere für den Fall der Patenterteilung oder GM-Enttragung.

Calibration data:

Name	Dim	Hex. limits	Phys. limits	Resol.	Unit
IP_MAF_MIN_COP__N_32__IGA_COP	6 x 4	0...FFH	0...1389	5,4471	mg/TDC
Minimum mass air flow threshold for catalyst overheating prevention activation.					
IP_TI_COP__N_32__MAF	6 x 6	0...FFH	0...0,996	0,0039	-
Injection time correction versus engine operating point for catalyst overheating prevention.					
IP_TI_COP_IGA__IGA_COP	4	0...FFH	-0,5...0,496	0,0039	-
Injection time correction versus ignition angle correction through knock control for catalyst overheating prevention.					
C_MAF_MIN_HYS_COP	1	0...FFH	0...1389	5,4471	mg/TDC
Hysteresis for minimum mass air flow threshold for catalyst overheating prevention deactivation.					
C_TI_COP_INC	1	0...80H	0...0,5	0,0039	-
Injection time change limitation in case of activation or deactivation of catalyst overheating prevention function.					
C_TI_COP_COR	1	0...1000H	0...1	0,000244 14	-
Injection time correction in case of catalyst overheating prevention activation with fuel shut-off out of vehicle speed limitation.					
C_IGA_MIN_COP	1	80...00H	-48...0	0,375	°CRK
Ignition angle correction threshold through knock control for catalyst overheating prevention deactivation.					

Editor: Müller O.	17-Dec-97	Injection	HMC_V6
Version: a 153589 from 18.12.97		657765.49.06	
File: CHAP_7.DOC	650H0000	Sourcefile:07700C01.00D	Page 45 / 121

1.2.3.5 Full load enrichment correction (TI_FL)

Output data:

Name	Mode	Hex. limits	Phys. limits	Resol.	Unit
TI_FL	V	0...FFH	0...0,9961	0,0039	-
Full load enrichment factor for nominal injection time.					

Input data:

LV_PL	LV_FL	N	
-------	-------	---	--

FUNCTION DESCRIPTION:

General information:

This enrichment is performed following engine operating state part load (LV_PL) with full load detected (LV_FL) in order improve performances and to ensure temperature limitation for outlet valves, catalyst converter and exhaust gas.

Application recurrence : **Segment** (when full load is detected : LV_FL = FL)

Formula section:

If LV_FL = 1 (FL) (full load function active)
then TI_FL = IP_TI_FL__N

If LV_FL = 0 (-) (full load function inactive)
then TI_FL = 0

Calibration data:

Name	Dim	Hex. limits	Phys. limits	Resol.	Unit
IP_TI_FL__N	16	00...FFH	0...0,997	3,895E-3	-
Full load enrichment factor for nominal injection time.					

Proprietary data, company confidential. All rights reserved. Contient a titre de secret d'entreprise. Tous droits réservés. Comunicado como segredo empresarial. Reservados todos os direitos. Confidado como secreto industrial. Nos reservamos todos los derechos.

Weitergabe sowie Vervielfältigung dieser Unterlage, Verwertung und Mitteilung ihres Inhalts nicht gestattet, soweit nicht ausdrücklich zugestanden. Zuwiderhandlungen verpflichten zu Schadenersatz. Alle Rechte vorbehalten, insbesondere für den Fall der Patenterteilung oder GM-Entragung.

Editor: Müller O.	17-Dec-97	Injection	HMC_V6
Version: a 153589 from 18.12.97		657765.49.06	
File: CHAP_7.DOC	650H0000	Sourcefile:07701001.00D	Page 46 / 121

1.2.3.6 Throttle acceleration enrichment correction (TI_TPS_AE)

Output data:

Name	Mode	Hex. limits	Phys. limits	Resol.	Unit
TI_TPS_AE	V	0...1FE0H	0...1,992	16 / 65536	-
Throttle acceleration enrichment factor for nominal injection time.					
LV_TPS_AE	V	0...01H	0...1	1	-
Boolean for the duration of throttle acceleration enrichment factor application - (Passive / Active).					

Input data:

ID_TPS_GRD_BOL_AE__N_32__TPS	TCO	MAF	N_32
ID_TPS_GRD_ADD_AE__TCO	TPS_GRD	LV_AE	

FUNCTION DESCRIPTION:

General information:

The acceleration quality is depending on the throttle position TPS taken during the transient phase and the throttle gradient TPS_GRD. When the engine load is changing during transient, there is a difference between the mass air flow measurement and the real mass air flow in the cylinders. The transient phase behaviour is depending on response time and fuel wall wetting phenomena.

The engine richness cannot be constant on each transient phase segment, that's why a temporary correction is applied on injection time. This correction TI_TPS_AE is quick and time limited to counteract the lean peak.

Application recurrence : **Segment**

Formula section:

* *First triggering - Initialisation :*

If LV_AE = 1 (AE) (acceleration enrichment function active)
then

$$TI_TPS_AE = IP_TI_TPS_FAC_AE(_AT)_TCO_TPS_GRD * ID_MAF_TPS_FAC_AE(_AT)_MAF$$

- and** initialisation of IP_TPS_SUM_CYCNR_AE (maximum duration for TI_TPS_AE re-triggering)
- and** initialisation of C_TPS_CYCNR_MIN_AE (timer for TI_TPS_AE re-triggering)
- and** initialisation of IP_TPS_CYCNR_AE(_AT)__N_32 (duration of TI_TPS_AE decrementation)
- and** LV_TPS_AE = 1 (Active)

Editor: Müller O.	17-Dec-97	Injection	HMC_V6
Version: a 153589 from 18.12.97		657765.49.06	
File: CHAP_7.DOC	650H0000	Sourcefile:07701101.00F	Page 47 / 121

Proprietary data, company confidential. All rights reserved. Contine a titre de secret d'entreprise. Tous droits réservés. Comunicado como segredo empresarial. Reservados todos os direitos. Confidado como secreto industrial. Nos reservamos todos los derechos.

Weitergabe sowie Vervielfältigung dieser Unterlage, Verbreitung und Mitteilung ihres Inhalts nicht gestattet, soweit nicht ausdrücklich zugestanden. Zuwiderhandlungen verpflichten zu Schadenersatz. Alle Rechte vorbehalten, insbesondere für den Fall der Patenterteilung oder GM-Entragung.

Remark :

The value from ID_MAF_TPS_FAC_AE(_AT)__MAF is set only when acceleration enrichment is detected for the first time.

Then, TI_TPS_AE is updated with IP_TI_TPS_FAC_AE(_AT)__TCO__TPS_GRD using the recurrence of TPS_GRD calculation (**Segment** recurrence if N < 2000 rpm else **10 msec.**).

* New triggering :

```

If          LV_AE = 1 (AE)                (acceleration enrichment function active)
and        LV_TPS_AE = 1 (Active)        ( TI_TPS_AE ≠ 0 )
and        IP_TPS_SUM_CYCNR_AE not elapsed
then
if         TPS_GRD ≥ ID_TPS_GRD_BOL_AE__N_32__TPS + ID_TPS_GRD_ADD_AE__TCO
and        TPS_GRD ≥ 0
and        TI_TPS_AEnew calculation ≥ TI_TPS_AE previous calculation
then
and        TI_TPS_AE new calculation is applied
and        C_TPS_CYCNR_MIN_AE is initialized again
else       TI_TPS_AE is performed until IP_TPS_SUM_CYCNR_AE is reached.
    
```

* Decrementation :

When IP_TPS_SUM_CYCNR_AE is reached, then TI_TPS_AE is in linear way decremented to 0 during IP_TPS_CYCNR_AE(_AT)__N_32 segments.

Remark :

When the re-triggering timer (set with C_TPS_CYCNR_MIN_AE) has elapsed and when the decrementation timer (set with IP_TPS_CYCNR_AE(_AT)__N_32) has also elapsed, then LV_TPS_AE = 0 (Passive) and TI_TPS_AE = 0.

Editor: Müller O.	17-Dec-97	Injection	HMC_V6
Version: a 153589 from 18.12.97		657765.49.06	
File: CHAP_7.DOC	650H0000	Sourcefile:07701101.00F	Page 48 / 121

Description:

Proprietary data, company confidential. All rights reserved.
 Contient des informations confidentielles. Tous droits réservés.
 Confidantele informatie van de onderneming. Alle rechten voorbehouden.
 Comunicado como secreto empresarial. Reservados todos los derechos.
 Confiado como secreto industrial. Nos reservamos todos los derechos.

Weitergabe sowie Vervielfältigung dieser Unterlage, Verwertung und Mitteilung ihres Inhalts ist gestattet, soweit nicht ausdrücklich zugestanden. Zuwiderhandlungen verpflichten zu Schadensersatz. Alle Rechte vorbehalten, insbesondere für den Fall der Patenterteilung oder GM-Eintragung.

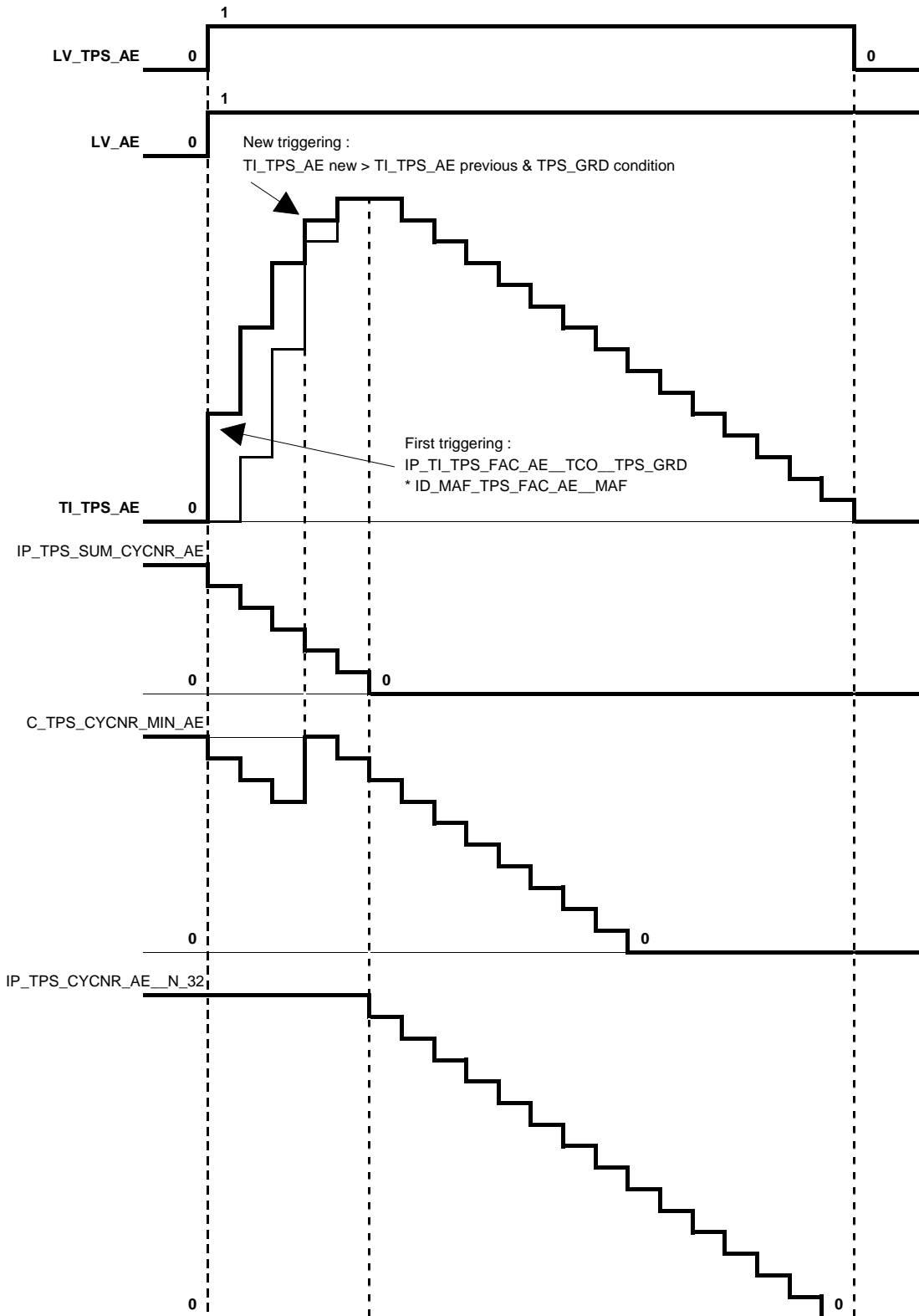

Editor: Müller O.	17-Dec-97	Injection	HMC_V6
Version: a 153589 from 18.12.97		657765.49.06	
File: CHAP_7.DOC	650H0000	Sourcefile:07701101.00F	Page 49 / 121

Calibration data:

Name	Dim	Hex. limits	Phys. limits	Resol.	Unit
IP_TI_TPS_FAC_AE(_AT)__TCO__TPS_GRD	6 x 6	00...FFH	0...3,98	1,562E-2	-
Basic factor for throttle acceleration enrichment correction.					
ID_MAF_TPS_FAC_AE(_AT)__MAF	4	00...FFH	0...0,997	3,895E-3	-
Initialisation value versus MAF for acceleration enrichment correction calculation.					
IP_TPS_CYCNR_AE(_AT)__N_32	4	01...FFH	1...255	1	-
Duration of TI_TPS_AE reset.					
C_TPS_CYCNR_MIN_AE	1	01...FFH	1...255	1	-
Re-triggering timer for throttle acceleration enrichment correction.					
IP_TPS_SUM_CYCNR_AE__N_32	4	01...20H	1...32	1	-
Maximum duration of TI_TPS_AE updating calculation.					

Proprietary data, company confidential. All rights reserved.
 Contient des données confidentielles de la société. Tous droits réservés.
 Comunicado como segredo empresarial. Reservados todos los derechos.
 Confidado como secreto industrial. Nos reservamos todos los derechos.

Weitergabe sowie Vervielfältigung dieser Unterlage, Verwertung und Mitteilung ihres Inhalts ist gestattet, soweit nicht ausdrücklich zugestanden. Zuwiderhandlungen verpflichten zu Schadensersatz. Alle Rechte vorbehalten, insbesondere für den Fall der Patenterteilung oder GM-Eintragung.

Editor: Müller O.	17-Dec-97	Injection	HMC_V6
Version: a 153589 from 18.12.97		657765.49.06	
File: CHAP_7.DOC	650H0000	Sourcefile:07701101.00F	Page 50 / 121

1.2.3.7 Load acceleration enrichment correction (TI_MAF_AE)

Output data:

Name	Mode	Hex. limits	Phys. limits	Resol.	Unit
TI_MAF_AE	V	0...FDFFH	0...15,8745	16 / 65536	-
Load acceleration enrichment factor correction for nominal injection time.					

Input data:

MAF_RATIO_AE	TCO	ID_TPS_GRD_ADD_AE_TCO	MAF
TPS_GRD	TPS	ID_TPS_GRD_BOL_AE_N_32_TPS	LV_AE
N_32			

FUNCTION DESCRIPTION:

General information:

The acceleration quality is depending on the wall wetting phenomena and the injection time correction factor TI_MAF_AE is representative of it.

The engine richness cannot be constant on each transient phase segment, that's why a temporary correction is applied on injection time. This correction TI_MAF_AE is working together with the throttle acceleration enrichment correction and must compensate the lean trail.

Application recurrence : **Segment**

Formula section:

* *First triggering - Initialisation :*

If LV_AE = 1 (AE) *(acceleration enrichment function active)*
then the corresponding mass air flow filtering factor MAF_CRLC is set
and the calculation of MAF_RATIO_AE is performed
and

$TI_MAF_AE = IP_TI_FAC_AE(AT)_N_32_MAF * IP_TI_FAC_TRA_AE(AT)_MAF_RATIO_AE_TCO$

and TI_CYCNR_AE = 0 - Initialisation
 (timer for TI_MAF_AE re-triggering - CYC calculation)
and initialisation of IP_TI_FAC_x_AE_RST_CYC
 (deactivation factor of TI_MAF_AE)
If TCO < C_TCO_AE_RST
then IP_TI_FAC_x_AE_RST_CYC = IP_TI_FAC_1_AE_RST(AT)_CYC
else IP_TI_FAC_x_AE_RST_CYC = IP_TI_FAC_2_AE_RST(AT)_CYC

Proprietary data, company confidential. All rights reserved. Contine a titre de secret d'entreprise. Tous droits réservés. Comunicado como segredo empresarial. Reservados todos os direitos. Confidado como secreto industrial. Nos reservamos todos los derechos.

Weitergabe sowie Vervielfältigung dieser Unterlage, Verwertung und Mitteilung ihres Inhalts nicht gestattet, soweit nicht ausdrücklich zugestanden. Zuwiderhandlungen verpflichten zu Schadensersatz. Alle Rechte vorbehalten, insbesondere für den Fall der Patenterteilung oder GM-Entragung.

Remark :

* The value from IP_TI_FAC_AE(AT)_N_32_MAF is set only on the first triggering of the load acceleration enrichment correction.
Then, TI_MAF_AE is updated with IP_TI_FAC_TRA_AE(AT)_MAF_RATIO_AE_TCO using the segment recurrence.

* The timer for TI_MAF_AE re-triggering is calculating as following :

$$CYC_n = 1 - TI_CYCNR_AE_n / IP_TI_CYCNR_AE(AT)_N_32_TCO$$

The value from IP_TI_CYCNR_AE(AT)_N_32_TCO is set only on the first triggering of the load acceleration enrichment correction.

* New triggering :

If LV_AE = 1 (AE) *(acceleration enrichment function active)*
and CYC_n ≤ C_CYC_MAX_AE
then
if TPS_GRD ≥ ID_TPS_GRD_BOL_AE_N_32_TPS+ ID_TPS_GRD_ADD_AE_TCO
and TPS_GRD ≥ 0
and TI_MAF_AE new calculation ≥ TI_MAF_AE previous calculation
then the first triggering is performed again with TI_MAF_AE new calculation
else TI_MAF_AE is continuously calculated as following :

$$TI_MAF_AE = IP_TI_FAC_AE(AT)_N_32_MAF * IP_TI_FAC_TRA_AE(AT)_MAF_RATIO_AE_TCO * IP_TI_FAC_x_AE_RST_CYC$$

and TI_CYCNR_AE_n = TI_CYCNR_AE_{n-1} + 1
 (n is the segment recurrence)
 until TI_MAF_AE = 0 is reached

Proprietary data, company confidential. All rights reserved. Contient a titre de secret d'entreprise. Tous droits réservés. Comunicado como secreto empresarial. Reservados todos os direitos. Confidado como secreto industrial. Nos reservamos todos los derechos.

Weitergabe sowie Vervielfältigung dieser Unterlage, Wertung und Mitteilung ihres Inhalts nicht gestattet, soweit nicht ausdrücklich zugestanden. Zuwiderhandlungen verpflichten zu Schadensersatz. Alle Rechte vorbehalten, insbesondere für den Fall der Patenterteilung oder GM-Entragung.

Editor: Müller O.	17-Dec-97	Injection	HMC_V6
Version: a 153589 from 18.12.97		657765.49.06	
File: CHAP_7.DOC	650H0000	Sourcefile:07701201.00E	Page 52 / 121

Description:

Proprietary data, company confidential. All rights reserved.
 Contit a titre de secret d'entreprise. Tous droits réservés.
 Comunicado como segredo empresarial. Reservados todos os direitos.
 Confidado como secreto industrial. Nos reservamos todos los derechos.

Weitergabe sowie Vervielfältigung dieser Unterlage, Ver-
 wertung und Mitteilung ihres Inhalts nicht gestattet, soweit
 nicht ausdrücklich zugestanden. Zuwiderhandlungen ver-
 pflichten zu Schadensersatz. Alle Rechte vorbehalten, insbe-
 sondere für den Fall der Patenterteilung oder GM-Entragung

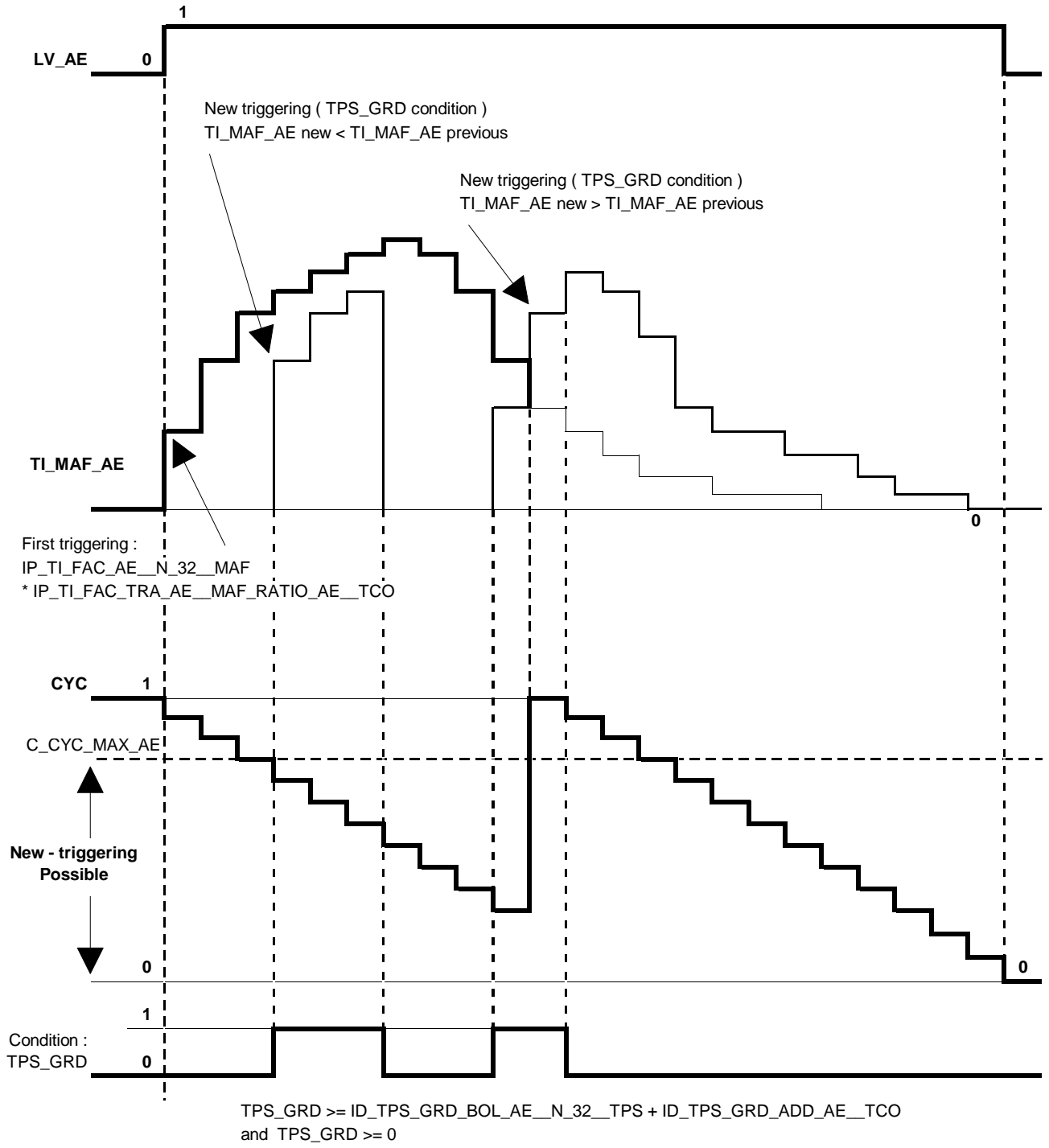

Editor: Müller O.	17-Dec-97	Injection	HMC_V6
Version: a 153589 from 18.12.97		657765.49.06	
File: CHAP_7.DOC	650H0000	Sourcefile:07701201.00E	Page 53 / 121

Calibration data:

Name	Dim	Hex. limits	Phys. limits	Resol.	Unit
IP_TI_FAC_AE(_AT)__N_32__MAF	4 x 4	0...FFH	0...1,9922	2 / 256	-
Initialisation factor for load acceleration enrichment correction, versus engine operating point.					
IP_TI_FAC_TRA_AE(_AT)__MAF_RATIO_AE__TCO	4 x 6	0...7FFFH	0...7,9995	8 / 32768	-
Basic factor for load acceleration enrichment correction.					
IP_TI_CYCNR_AE(_AT)__N_32__TCO	4 x 6	01...FFFFH	1...65535	1	-
Re-triggering timer for load acceleration enrichment correction.					
IP_TI_FAC_1_AE_RST(_AT)__CYC	6	00...FFH	0...0,997	3,895E-3	-
Load acceleration enrichment deactivation factor if TCO < C_TCO_AE_RST.					
IP_TI_FAC_2_AE_RST(_AT)__CYC	6	00...FFH	0...0,997	3,895E-3	-
Load acceleration enrichment deactivation factor if TCO (C_TCO_AE_RST.					
C_TCO_AE_RST	1	0...FEH	-48...142,5	0,75	-
Coolant temperature threshold for selection of load acceleration enrichment deactivation factor.					
C_CYC_MAX_AE	1	00...FFH	0...0,997	3,895E-3	-
CYC value threshold for TI_MAF_AE re-triggering authorization.					

Proprietary data, company confidential. All rights reserved. Contient des informations confidentielles de la société Siemens. Toute réimpression ou utilisation non autorisée sans la permission écrite de la société est formellement interdite. Reservados todos los derechos. No se permite la explotación económica ni la transformación de esta obra. Queda permitida la impresión en su totalidad. Reservados todos los derechos. No se permite la explotación económica ni la transformación de esta obra. Queda permitida la impresión en su totalidad.

Weitergabe sowie Vervielfältigung dieser Unterlage, Verwertung und Mitteilung ihres Inhalts ist gestattet, soweit nicht ausdrücklich zugestanden. Zuwiderhandlungen verpflichten zu Schadensersatz. Alle Rechte vorbehalten, insbesondere für den Fall der Patenterteilung oder GM-Entragung.

Editor: Müller O.	17-Dec-97	Injection	HMC_V6
Version: a 153589 from 18.12.97		657765.49.06	
File: CHAP_7.DOC	650H0000	Sourcefile:07701201.00E	Page 54 / 121

1.2.3.8 Trailing throttle fuel reduction correction (TI_PUR)

Output data:

Name	Mode	Hex. limits	Phys. limits	Resol.	Unit
TI_PUR	V	0...0FD0H	0...0,9883	16 / 65536	-
Trailing throttle fuel reduction correction for nominal injection time.					

Input data:

LV_PUR	N_32	TCO	MAF
MAF_RATIO_PUR			

FUNCTION DESCRIPTION:

General information:

In trailing throttle, a richness peak is sometimes met. That's why, in order to keep the engine richness 1, the injection time is reduced to compensate the increased fuel film evaporation due to decreased intake manifold pressure.

This function is similar to the load acceleration enrichment correction but takes place during decelerations instead of accelerations.

Application recurrence : **Segment**

Formula section:

* *First triggering - Initialisation :*

If LV_PUR = 1 (PUR) *(trailing throttle fuel reduction function active)*
then the corresponding mass air flow filtering factor MAF_CRLC is set
and the calculation of MAF_RATIO_PUR is performed
and

$TI_PUR = IP_TI_FAC_PUR_N_32_MAF * IP_TI_FAC_TRA_PUR(AT)_MAF_RATIO_PUR_TCO$
--

and TI_CYCNR_PUR = 0 - Initialisation
 (timer for TI_PUR re-triggering - CYC calculation)
and initialisation of IP_TI_FAC_PUR_RST(AT)_CYC
 (deactivation factor of TI_PUR)

Proprietary data, company confidential. All rights reserved. Contine a titre de secret d'entreprise. Tous droits réservés. Comunicado como segredo empresarial. Reservados todos os direitos. Confidado como secreto industrial. Nos reservamos todos los derechos.

Weitergabe sowie Vervielfältigung dieser Unterlage, Verbreitung und Mitteilung ihres Inhalts nicht gestattet, soweit nicht ausdrücklich zugestanden. Zuwiderhandlungen verpflichten zu Schadensersatz. Alle Rechte vorbehalten, insbesondere für den Fall der Patenterteilung oder GM-Entragung.

Editor: Müller O.	17-Dec-97	Injection	HMC_V6
Version: a 153589 from 18.12.97		657765.49.06	
File: CHAP_7.DOC	650H0000	Sourcefile:07701301.00D	Page 55 / 121

Proprietary data, company confidential. All rights reserved. Contine a titre de secret d'entreprise. Tous droits réservés. Comunicado como segredo empresarial. Reservados todos os direitos. Confidado como secreto industrial. Nos reservamos todos los derechos.

Weitergabe sowie Vervielfältigung dieser Unterlage, Wertung und Mitteilung ihres Inhalts nicht gestattet, soweit nicht ausdrücklich zugestanden. Zuwiderhandlungen verpflichten zu Schadensersatz. Alle Rechte vorbehalten, insbesondere für den Fall der Patenterteilung oder GM-Entragung

Remark :

* The value from IP_TI_FAC_PUR__N_32__MAF is set only on the first triggering of the trailing throttle fuel reduction function.

Then, TI_PUR is updated with IP_TI_FAC_TRA_PUR(_AT)__MAF_RATIO_PUR__TCO using the segment recurrence.

* The timer for TI_PUR re-triggering is calculating as following :

$$CYC_n = 1 - TI_CYCNR_PUR_n / IP_TI_CYCNR_PUR_(_AT)_N_32_TCO$$

The value from IP_TI_CYCNR_PUR(_AT)__N_32__TCO is set only on the first triggering of the trailing throttle fuel reduction function.

* New triggering :

If LV_PUR = 1 (PUR) *(trailing throttle fuel reduction function active)*
then TI_PUR is continuously calculated as following :

TI_PUR = IP_TI_FAC_PUR__N_32__MAF
 * IP_TI_FAC_TRA_PUR(_AT)__MAF_RATIO_PUR__TCO
 * IP_TI_FAC_PUR_RST(_AT)__CYC

and TI_CYCNR_PUR_n = TI_CYCNR_PUR_{n-1} + 1
 until TI_PUR = 0 is reached (n is the segment recurrence)

Editor: Müller O.	17-Dec-97	Injection	HMC_V6
Version: a 153589 from 18.12.97		657765.49.06	
File: CHAP_7.DOC	650H0000	Sourcefile:07701301.00D	Page 56 / 121

Description:

Proprietary data, company confidential. All rights reserved.
 Contitue a titre de secret d'entreprise. Tous droits réservés.
 Comunicado como secreto empresarial. Reservados todos os direitos.
 Confidado como secreto industrial. Nos reservamos todos los derechos.

Weitergabe sowie Vervielfältigung dieser Unterlage, Verwertung und Mitteilung ihres Inhalts nicht gestattet, soweit nicht ausdrücklich zugestanden. Zuwiderhandlungen verpflichten zu Schadensersatz. Alle Rechte vorbehalten, insbesondere für den Fall der Patenterteilung oder GM-Eintragung.

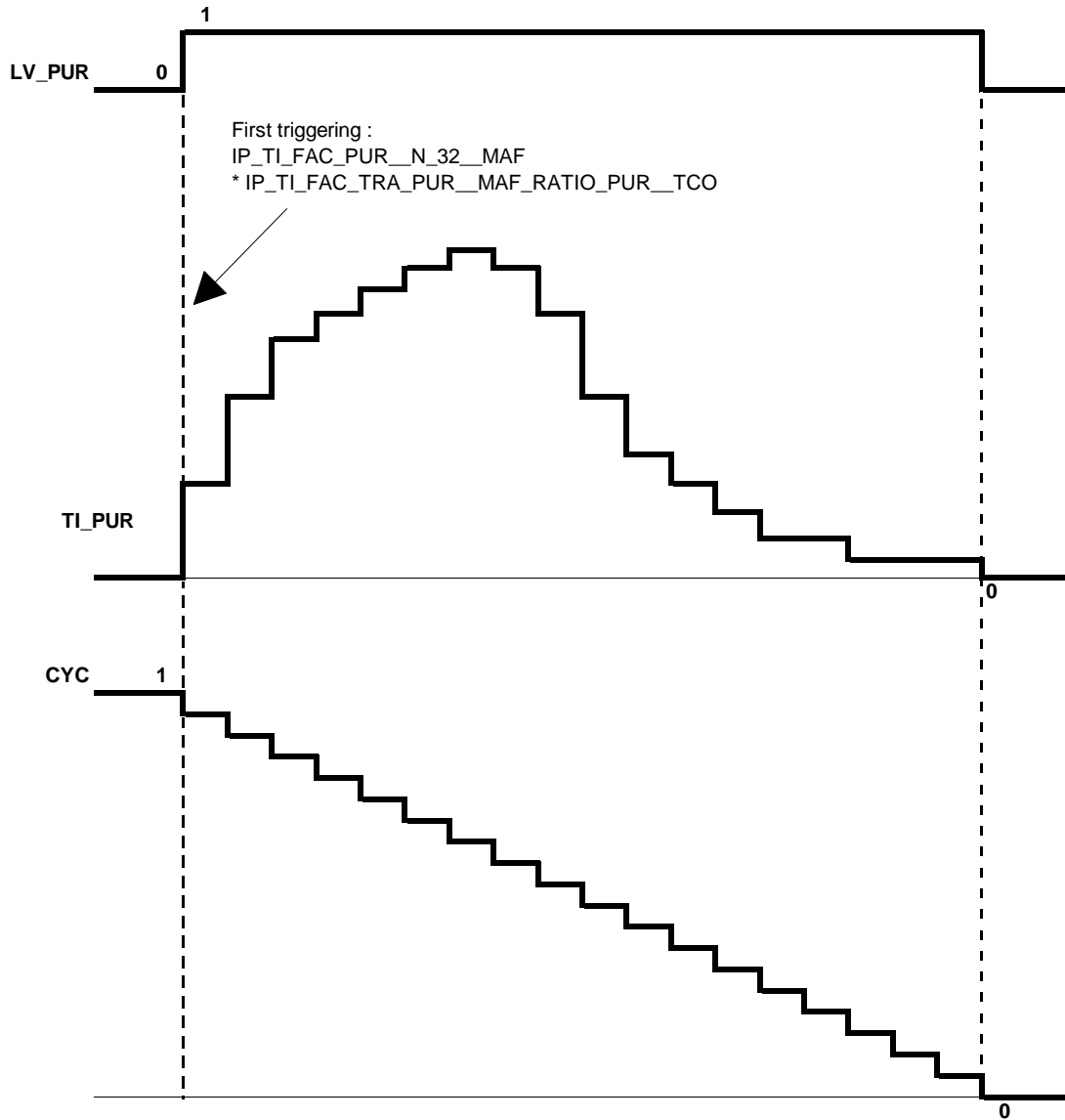

Editor:	Müller O.	17-Dec-97	Injection	HMC_V6
Version:	a 153589 from 18.12.97		657765.49.06	
File:	CHAP_7.DOC	650H0000	Sourcefile:07701301.00D	Page 57 / 121

Calibration data:

Name	Dim	Hex. limits	Phys. limits	Resol.	Unit
IP_TI_FAC_PUR(_AT)__N_32__MAF	4 x 4	0...FFH	0...0,9961	1 / 256	-
Initialisation factor for trailing throttle fuel reduction correction, versus engine operating point.					
IP_TI_FAC_TRA_PUR(_AT)__MAF_RATIO_PUR__TCO	4 x 6	0...03FCH	0...3,9844	1 / 256	-
Basic factor for trailing throttle fuel reduction correction.					
IP_TI_CYCNR_PUR(_AT)__N_32__TCO	4 x 4	01...FFFFH	1...65535	1	-
Re-triggering timer for trailing throttle fuel reduction correction.					
IP_TI_FAC_PUR_RST(_AT)__CYC	6	0...FFH	0...0,9961	1 / 256	-
Trailing throttle fuel reduction deactivation factor.					

Proprietary data, company confidential. All rights reserved. Contient a titre de secret d'entreprise. Tous droits réservés. Comunicado como segredo empresarial. Reservados todos os direitos. Confidado como secreto industrial. Nos reservamos todos los derechos.

Weitergabe sowie Vervielfältigung dieser Unterlage, Wertung und Mitteilung ihres Inhalts nicht gestattet, soweit nicht ausdrücklich zugestanden. Zuwiderhandlungen verpflichten zu Schadensersatz. Alle Rechte vorbehalten, insbesondere für den Fall der Patenterteilung oder GM-Eintragung.

Editor: Müller O.	17-Dec-97	Injection	HMC_V6
Version: a 153589 from 18.12.97		657765.49.06	
File: CHAP_7.DOC	650H0000	Sourcefile:07701301.00D	Page 58 / 121

1.2.3.9 Idle speed correction (TI_IS)

Output data:

Name	Mode	Hex. limits	Phys. limits	Resol.	Unit
TI_IS	V	0...FFH	-0,5...0,496	1 / 256	-
Idle speed correction for nominal injection time.					

Input data:

LV_IS	LV_ISAPWM_IS_ACT	N_DIF_COR	
-------	------------------	-----------	--

FUNCTION DESCRIPTION:

General information:

In order to achieve an engine speed stabilization at idle (LV_IS), a mixture correction is performed as soon as the idle speed regulation is active.

Application recurrence : **Segment**

Formula section:

If engine operating state idle (LV_IS) active
and LV_ISAPWM_IS_ACT = 1 (Active) (*idle speed regulation correction active*)
then TI_IS = IP_TI_IS__N_DIF_COR
else TI_IS = 0

Calibration data:

Name	Dim	Hex. limits	Phys. limits	Resol.	Unit
IP_TI_IS__N_DIF_COR	6	0...FFH	-0,5...0,496	1 / 256	-
Idle speed correction for nominal injection time.					

Proprietary data, company confidential. All rights reserved. Contine a titre de secret d'entreprise. Tous droits réservés. Comunicado como segredo empresarial. Reservados todos os direitos. Confidado como secreto industrial. Nos reservamos todos los derechos.

Weitergabe sowie Vervielfältigung dieser Unterlage, Verwertung und Mitteilung ihres Inhalts nicht gestattet, soweit nicht ausdrücklich zugestanden. Zuwiderhandlungen verpflichten zu Schadenersatz. Alle Rechte vorbehalten, insbesondere für den Fall der Patenterteilung oder GM-Eintragung

Editor: Müller O.	17-Dec-97	Injection	HMC_V6
Version: a 153589 from 18.12.97		657765.49.06	
File: CHAP_7.DOC	650H0000	Sourcefile:07701401.00D	Page 59 / 121

1.2.3.10 Altitude correction factor (TI_FAC_ALTI)

Output data:

Name	Mode	Hex. limits	Phys. limits	Resol.	Unit
TI_FAC_ALTI	-	80...FFH	0,5...0,9961	0,0039	-
Altitude injection time correction factor.					

Input data:

MAF_FAC_ALTI_MMV			
------------------	--	--	--

FUNCTION DESCRIPTION:

General information:

The pre-injection time and injection time at start is corrected with the altitude correction factor TI_FAC_ALTI, which depends on the mass air flow correction factor MAF_FAC_ALTI_MMV. For total formula see chapters 1.1.1.1.1. and 1.1.1.1.2.

Formula section:

$$TI_FAC_ALTI = IP_TI_FAC_ALTI_MAF_FAC_ALTI_MMV$$

Calibration data:

Name	Dim	Hex. limits	Phys. limits	Resol.	Unit
IP_TI_FAC_ALTI__MAF_FAC_ALTI_MMV	8	80...FFH	0,5...0,9961	0,0039	-
Weighting factor of pre injection time basic value due to altitude correction.					

Proprietary data, company confidential. All rights reserved. Contient a titre de secret d'entreprise. Tous droits réservés. Comunicado como segredo empresarial. Reservados todos os direitos. Confidado como secreto industrial. Nos reservamos todos los derechos.

Weitergabe sowie Vervielfältigung dieser Unterlage, Verwertung und Mitteilung ihres Inhalts nicht gestattet, soweit nicht ausdrücklich zugestanden. Zuwiderhandlungen verpflichten zu Schadensersatz. Alle Rechte vorbehalten, insbesondere für den Fall der Patenterteilung oder GM-Entragung.

Editor: Müller O.	17-Dec-97	Injection	HMC_V6
Version: a 153589 from 18.12.97		657765.49.06	
File: CHAP_7.DOC	650H0000	Sourcefile:07702001.00A	Page 60 / 121

1.2.3.11 Acceleration enrichment correction (TI_AE)

Output data:

Name	Mode	Hex. limits	Phys. limits	Resol.	Unit
TI_AE	V	0...FFFFH	0...15,9998	16 / 65536	-
Acceleration enrichment factor correction for nominal injection time.					

Input data:

TI_TPS_AE	TI_MAF_AE	LV_AE	
-----------	-----------	-------	--

FUNCTION DESCRIPTION:

General information:

The acceleration quality is depending on measurement response time and fuel wall wetting phenomena.

The injection time correction factor TI_AE is representative of them.

The engine richness cannot be constant on each transient phase segment, that's why this temporary correction is applied on nominal injection time. This correction TI_AE is the result of the throttle acceleration enrichment correction TI_TPS_AE and the load acceleration enrichment correction TI_MAF_AE.

Application recurrence : **Segment**

Formula section:

TI_AE = TI_TPS_AE + TI_MAF_AE

Remark :

The calculation is made independently of the acceleration enrichment information (LV_AE).

Proprietary data, company confidential. All rights reserved. Contine a titre de secret d'entreprise. Tous droits réservés. Comunicado como segredo empresarial. Reservados todos os direitos. Confidado como secreto industrial. Nos reservamos todos los derechos.

Weitergabe sowie Vervielfältigung dieser Unterlage, Verwertung und Mitteilung ihres Inhalts nicht gestattet, soweit nicht ausdrücklich zugestanden. Zuwiderhandlungen verpflichten zu Schadensersatz. Alle Rechte vorbehalten, insbesondere für den Fall der Patenterteilung oder GM-Entragung.

Editor: Müller O.	17-Dec-97	Injection	HMC_V6
Version: a 153589 from 18.12.97		657765.49.06	
File: CHAP_7.DOC	650H0000	Sourcefile:07701601.00B	Page 61 / 121

1.2.4 Cylinder fuel shut-off

Output data:

Name	Mode	Hex. limits	Phys. limits	Resol.	Unit
PAT_INH_IV	V	00...maxH	0...max	1	-
Fuel shut-off pattern index - max = NC_INI_INH_SWI_IV_SHIFT_NR.					
INH_SWI_IV	-	0...1FFFH	0...8191	1	-
Fuel shut-off pattern for 6 cylinders engine.					

Input data:

PAT_INH_IV_VS_MAX	PAT_INH_IV_N_MAX	PAT_INH_IV_TQR	LV_IGK
PAT_INH_IV_PUC_REAC			

FUNCTION DESCRIPTION:

General information:

For the following auxiliary functions injection must be disabled for individual cylinders :

- engine speed limitation
- vehicle speed limitation
- torque reduction requested by TCS (Traction Control System).
- Fuel cut-off
- Rewetting in Part Load

(refer to the chapter " Fuel injection output " in the major chapter " Outputs ")

Application recurrence : **Segment**

Formula section:

If ignition key is detected off (LV_IGK = 0 (Passive))
then PAT_INH_IV_n = NC_INI_INH_SWI_IV_SHIFT_NR
else PAT_INH_IV_n = max { PAT_INH_IV_N_MAX, (engine speed limitation)
 PAT_INH_IV_VS_MAX, (vehicle speed limitation)
 PAT_INH_IV_TQR (torque red. req. by TCS or TCU)
 PAT_INH_IV_PUC_REAC (Progressive PUC Phase
 and Rewetting in PL)

If PAT_INH_IV_n > PAT_INH_IV_{n-1}
then INH_SWI_IV = ID_PAT_INH_IV__PAT_INH_IV_n + 8000H
else INH_SWI_IV = ID_PAT_INH_IV__PAT_INH_IV_n

Editor: Müller O.	17-Dec-97	Injection	HMC_V6
Version: a 153589 from 18.12.97		657765.49.06	
File: CHAP_7.DOC	650H0000	Sourcefile:07701701.00B	Page 62 / 121

Description:

Proprietary data, company confidential. All rights reserved.
 Contient des informations confidentielles. Tous droits réservés.
 Comunicado como segredo empresarial. Reservados todos os direitos.
 Confidado como secreto industrial. Nos reservamos todos los derechos.

Pattern Index	Pattern Decimal	Pattern Binary												Firing order for 6 cyl. engine											
		1	2	3	4	5	6	1	2	3	4	5	6	1	2	3	4	5	6	1	2				
0	0	0	0	0	0	0	0	0	0	0	0	0	0	0	0	0	0	0	0	0	0	0			
1	4096	1	0	0	0	0	0	0	0	0	0	0	0	0	0	0	0	0	0	0	0	0			
2	4160	1	0	0	0	0	0	1	0	0	0	0	0	0	0	1	0	0	0	0	0	0			
3	4368	1	0	0	0	1	0	0	0	1	0	0	0	0	1	0	0	0	1	0	0	0			
4	4680	1	0	0	1	0	0	1	0	0	1	0	0	0	1	0	0	1	0	0	0	0			
5	4682	1	0	0	1	0	0	1	0	0	1	0	1	0	1	0	1	0	1	0	1	0			
6	5290	1	0	1	0	0	1	0	1	0	1	0	1	0	1	0	1	0	1	0	1	0			
7	5461	1	0	1	0	1	0	1	0	1	0	1	0	1	0	1	0	1	0	1	0	1			
8	6617	1	1	0	0	1	1	1	0	1	1	0	1	1	0	0	1	1	0	0	1	1			
9	7021	1	1	0	1	1	0	1	1	0	1	1	0	1	1	0	1	1	0	1	1	0			
10	7095	1	1	0	1	1	1	0	1	1	0	1	1	0	1	1	0	1	1	0	1	1			
11	7927	1	1	1	1	0	1	1	1	1	0	1	1	1	1	0	1	1	1	1	1	1			
12	8190	1	1	1	1	1	1	1	1	1	1	1	1	1	1	0	1	1	1	1	1	0			
13	8191	1	1	1	1	1	1	1	1	1	1	1	1	1	1	1	1	1	1	1	1	1			

Calibration data:

Weitergabe sowie Vervielfältigung dieser Unterlage, Verwertung und Mitteilung ihres Inhalts nicht gestattet, soweit nicht ausdrücklich zugestanden. Zuwiderhandlungen verpflichten zu Schadensersatz. Alle Rechte vorbehalten, insbesondere für den Fall der Patenterteilung oder GM-Entragung.

Name	Dim	Hex. limits	Phys. limits	Resol.	Unit
ID_PAT_INH_IV__PAT_INH_IV	14	0...1FFFH	0...8191	1	-
Fuel shut-off pattern for 6 cylinders engine.					
NC_INI_INH_SWI_IV_SHIFT_NR	1	0...FFH	0...255	1	-
Non adjustable calibration - Length of the pattern for fuel injection shut-off.					

Applicative Value :

NC_INI_INH_SWI_IV_SHIFT_NR = 0DH = 13 dec.

Editor: Müller O.	17-Dec-97	Injection	HMC_V6
Version: a 153589 from 18.12.97		657765.49.06	
File: CHAP_7.DOC	650H0000	Sourcefile:07701701.00B	Page 63 / 121

1.2.4.1 Progressive fuel cut-off (PUC) and rewetting in Part Load (PL)

Output data:

Name	Mode	Hex. limits	Phys. limits	Resol.	Unit
PAT_INH_IV_PUC_REAC	V	00...maxH	0...max	1	-
Fuel shut-off pattern for progressive fuel cut-off phase (PUC) and rewetting in Part Load (PL)					

Input data:

LV_PUC	NC_CYL_NO	NC_INI_INH_SWI_IV_SHIF T_NR	N_32
LV_PU	LV_PL	GR_MT	TCO
LV_TCO_ERR			

FUNCTION DESCRIPTION:

General information:

In order to have smooth decelerations and accelerations, cylinders are progressively:

- switched OFF when “Trailing Throttle Fuel Cut Off (PUC)” is detected.
- switched ON when a transition “Trailing Throttle Fuel Cut Off (PUC)” to Part Load (PL) is detected.

Progressive cylinder cut-off and rewetting mainly depends on Engine Speed and Gear Ratio.

Formula section:

- Progressive cylinder shut-off :

If Transition LV_PU -> LV_PUC is detected

Then Following sequence is started:

1. PAT_INH_IV_PUC_REAC = ID_PAT_INH_IV_PUC_1__N_32
during 2 * NC_CYL_NO segments
2. PAT_INH_IV_PUC_REAC = ID_PAT_INH_IV_PUC_2__N_32
during 2 * NC_CYL_NO segments
3. PAT_INH_IV_PUC_REAC = NC_INI_SWI_IV_SHIFT_NR

Proprietary data, company confidential. All rights reserved.
 Contit a titre de secret d'entreprise. Tous droits réservés.
 Comunicado como segredo empresarial. Reservados todos os direitos.
 Confidado como secreto industrial. Nos reservamos todos los derechos.

Weitergabe sowie Vervielfältigung dieser Unterlage, Verwertung und Mitteilung ihres Inhalts nicht gestattet, soweit nicht ausdrücklich zugestanden. Zuwiderhandlungen verpflichten zu Schadensersatz. Alle Rechte vorbehalten, insbesondere für den Fall der Patenterteilung oder GM-Entragung.

Editor: Müller O.	17-Dec-97	Injection	HMC_V6
Version: a 153589 from 18.12.97		657765.49.06	
File: CHAP_7.DOC	650H0000	Sourcefile:07701701.00B	Page 64 / 121

Proprietary data, company confidential. All rights reserved.
 Contiene datos de la empresa, reservados todos los derechos.
 Contiene a titre de secret d'entreprise. Tous droits réservés.
 Comunicado como secreto empresarial. Reservados todos os direitos.
 Confidado como secreto industrial. Nos reservamos todos los derechos.

Weitergabe sowie Vervielfältigung dieser Unterlage, Verwertung und Mitteilung ihres Inhalts nicht gestattet, soweit nicht ausdrücklich zugestanden. Zuwiderhandlungen verpflichten zu Schadensersatz. Alle Rechte vorbehalten, insbesondere für den Fall der Patenterteilung oder GM-Entragung

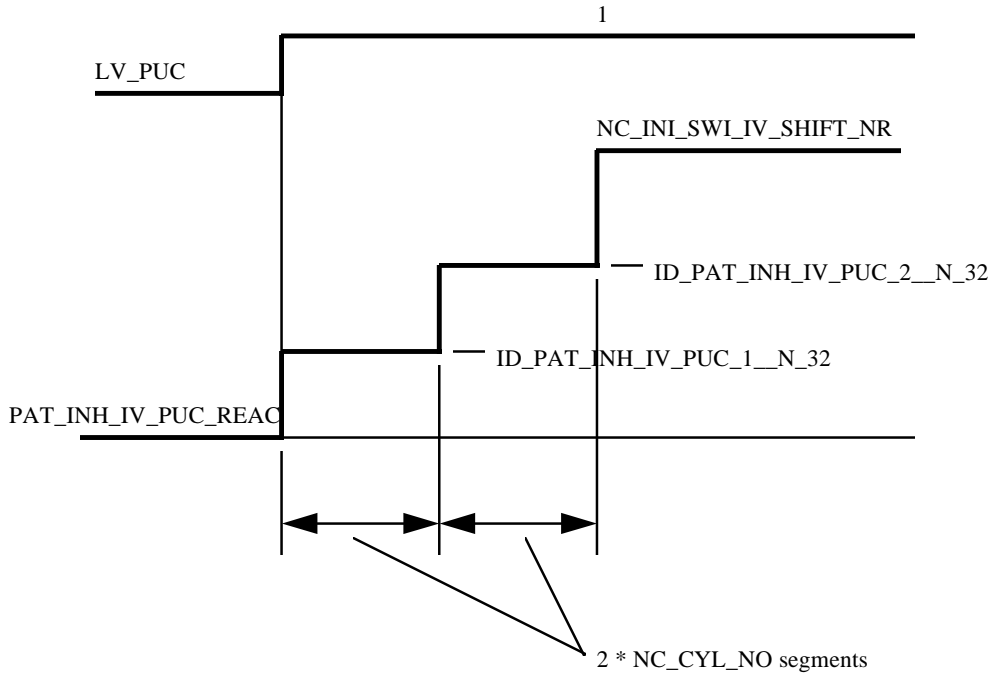

- Progressive cylinder rewetting :

If Transition LV_PUC -> LV_PL is detected
and TCO > C_TCO_PAT_REAC_MIN
and LV_TCO_ERR = 0

Then Following sequence is started **and** active if LV_PL = 1

1. PAT_INH_IV_PUC_REAC is set to ID_PAT_INH_IV_REAC__N_32__GR_MT during ID_PAT_CYCNR_REAC_N_32__GR_MT segments
2. PAT_INH_IV_PUC_REAC = 0

Else
 PAT_INH_IV_PUC_REAC = 0 immediately

Editor: Müller O.	17-Dec-97	Injection	HMC_V6
Version: a 153589 from 18.12.97		657765.49.06	
File: CHAP_7.DOC	650H0000	Sourcefile:07701701.00B	Page 65 / 121

Proprietary data, company confidential. All rights reserved.
 Contine a titre de secret d'entreprise. Tous droits réservés.
 Comunicado como segredo empresarial. Reservados todos os direitos.
 Confidado como secreto industrial. Nos reservamos todos los derechos.

Weitergabe sowie Vervielfältigung dieser Unterlage, Verwertung und Mitteilung ihres Inhalts nicht gestattet, soweit nicht ausdrücklich zugestanden. Zuwiderhandlungen verpflichten zu Schadenersatz. Alle Rechte vorbehalten, insbesondere für den Fall der Patenterteilung oder GM-Enttragung

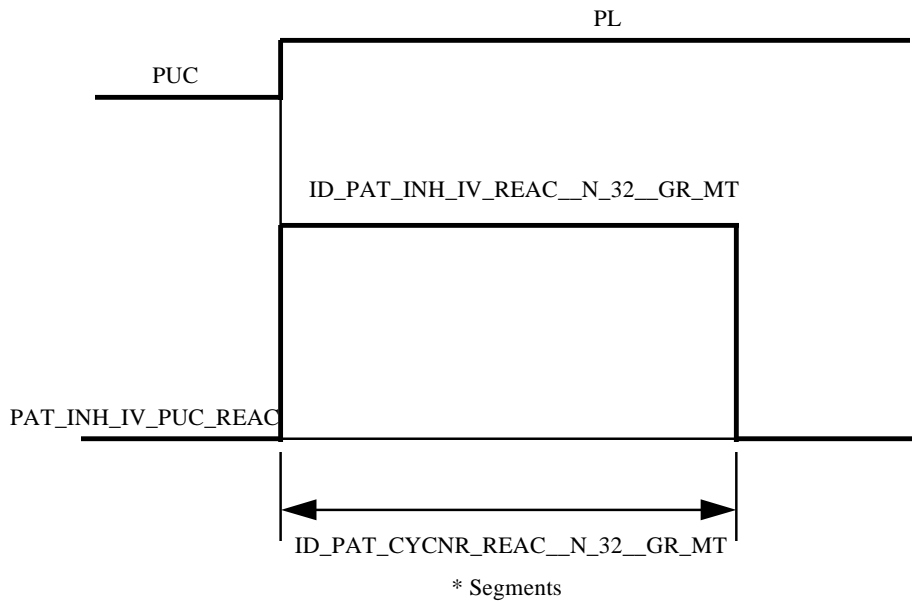

Calibration data:

Name	Dim	Hex. limits	Phys. limits	Resol.	Unit
ID_PAT_INH_IV_PUC_1__N_32	6	0...maxH	0...max	1	-
Fuel shut-off pattern in case of "Trailing Throttle Fuel Cut-Off - max = NC_INI_INH_SWI_IV_SHIFT_NR					
ID_PAT_INH_IV_PUC_2__N_32	6	0...maxH	0...8191	1	-
Fuel shut-off pattern in case of "Trailing Throttle Fuel Cut-Off - max = NC_INI_INH_SWI_IV_SHIFT_NR					
ID_PAT_INH_IV_REAC_N_32_GR_MT	6*6	0...maxH	0...max	1	-
Fuel shut-off pattern in case of transition PUC->PL - max = NC_INI_INH_SWI_IV_SHIFT_NR					
ID_PAT_CYCNR_REAC_N_32_GR_MT	6*6	0...FFH	0...255	1	Segment
Number of cycles to activate Fuel shut-off pattern in case of transition PUC->PL					
C_TCO_PAT_REAC_MIN	1	0...FEH	-48...142,5	0,75	°C
Minimum coolant temperature to activate progressive injection rewetting at transition to PL					

Editor: Müller O.	17-Dec-97	Injection	HMC_V6
Version: a 153589 from 18.12.97		657765.49.06	
File: CHAP_7.DOC	650H0000	Sourcefile:07701701.00B	Page 66 / 121

1.2.5 Individual cylinder re-start fuel feed (TI_ADD_REAC_SCC_[CYL])

Output data:

Name	Mode	Hex. limits	Phys. limits	Resol.	Unit
TI_ADD_REAC_SCC_[CYL]	V	8000...7FFFH	-131,072 ...131,068	4 µsec	msec
Individual cylinder re-start fuel feed.					

Input data:

TCO	N_32	TIB	
-----	------	-----	--

FUNCTION DESCRIPTION:

General information:

This function is provided to make sure that the cylinder fuel feed which is re-started after an individual fuel shut-off begins to ignite safely and without misfires ensuring a fast torque build-up. The corresponding cylinder must be supplied with an additional fuel quantity for the following reasons :

- increased cylinder fill due to lack of residual exhaust gas
- removal of the wall-applied fuel film during cylinder shut-off.

There is no differentiation as to whether fuel feed is re-started after any one of the engine operating states.

(refer to the chapter " Fuel injection output " in the major chapter " Outputs ")

Application recurrence : **Segment**

Formula section:

* Simulation of wall - applied fuel film removal (calculation) :

TI_DIF_WF_[CYL] is set only if cylinder individual **fuel shut-off** is requested from basis software layer.

It works like a **negative offset** for TI_ADD_REAC_SCC_[CYL] and performs the simulation of wall - applied fuel film removal.

$$TI_DIF_WF_ [CYL] = TIB * ID_TI_TCO_NEG_WF_TCO$$

As long as the corresponding cylinder is in fuel shut-off, an engine speed related additional fuel quantity ID_TI_INC_WF__N_32 is incremented cyclically at intervals of **720°** CRK until the cylinder fuel shut-off is terminated or TI_DIF_WF_[CYL] = 0.

Proprietary data, company confidential. All rights reserved. Contient a titre de secret d'entreprise. Tous droits réservés. Comunicado como segredo empresarial. Reservados todos os direitos. Confidado como secreto industrial. Nos reservamos todos los derechos.

Weitergabe sowie Vervielfältigung dieser Unterlage, Verwertung und Mitteilung ihres Inhalts nicht gestattet, soweit nicht ausdrücklich zugestanden. Zuwiderhandlungen verpflichten zu Schadensersatz. Alle Rechte vorbehalten, insbesondere für den Fall der Patenterteilung oder GM-Entragung.

* Additional injection quantity for re-starting fuel feed (application) :

TI_REAC_WF_[CYL] is set only if cylinder re-start **fuel feed** is requested from basis software layer.

It works like a **positive offset** for TI_ADD_REAC_SCC_[CYL] and performs the wall - applied fuel film, which is not not completely removed.

Due to residual exhaust gas, an additive injection time compensation is performed only during the first triggering of the re-start fuel feed.

$$TI_REAC_WF_ [CYL] = TIB * ID_TI_TCO_POS_WF_TCO + ID_TI_N_POS_RG_N_32$$

For reduction, an engine speed related decrement ID_TI_DEC_WF_N_32 is used until TI_ADD_REAC_SCC_[CYL] = 0.

Description:

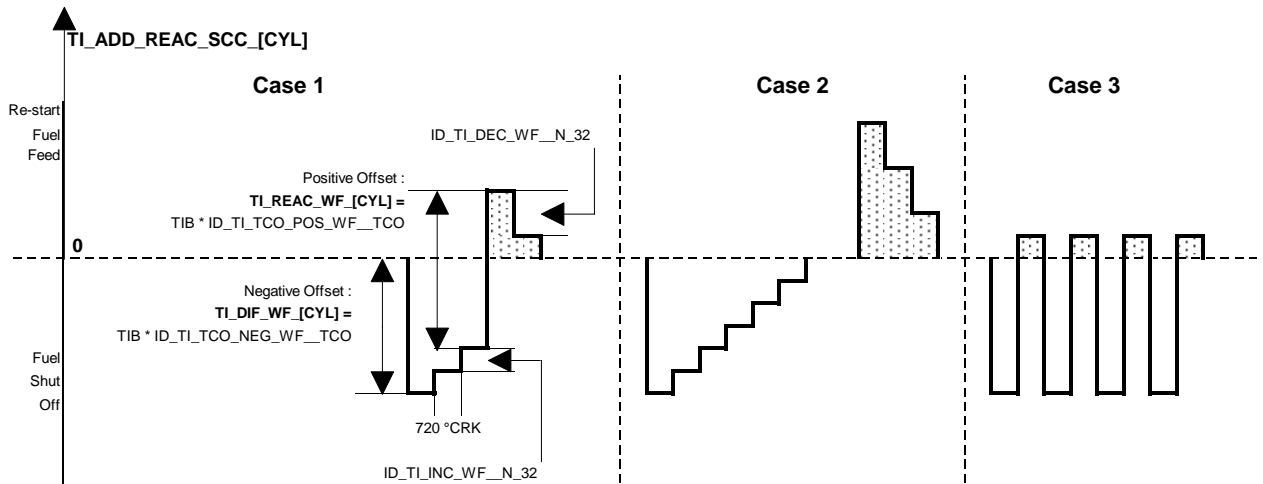

Proprietary data, company confidential. All rights reserved. Contine a titre de secret d'entreprise. Tous droits réservés. Comunicado como segredo empresarial. Reservados todos os direitos. Confidado como secreto industrial. Nos reservamos todos los derechos.

Weitergabe sowie Vervielfältigung dieser Unterlage, Verwertung und Mitteilung ihres Inhalts nicht gestattet, soweit nicht ausdrücklich zugestanden. Zuwiderhandlungen verpflichten zu Schadenersatz. Alle Rechte vorbehalten, insbesondere für den Fall der Patenterteilung oder GM-Entragung.

Editor: Müller O.	17-Dec-97	Injection	HMC_V6
Version: a 153589 from 18.12.97		657765.49.06	
File: CHAP_7.DOC	650H0000	Sourcefile:07701901.00D	Page 68 / 121

Proprietary data, company confidential. All rights reserved. Contine a titre de secret d'entreprise. Tous droits réservés. Comunicado como secreto empresarial. Reservados todos os direitos. Confidado como secreto industrial. Nos reservamos todos los derechos.

Weitergabe sowie Vervielfältigung dieser Unterlage, Verwertung und Mitteilung ihres Inhalts nicht gestattet, soweit nicht ausdrücklich zugestanden. Zuwiderhandlungen verpflichten zu Schadenersatz. Alle Rechte vorbehalten, insbesondere für den Fall der Patenterteilung oder GM-Entragung.

Case 1 : Re-start fuel feed is performed after 3 x 720 °CRK in fuel shut-off. The wall - applied fuel film has not been removed totally.

The re-starting fuel quantity TI_ADD_REAC_SCC_[CYL] starts with the negative value TI_DIF_WF_[CYL]. The additional injection is defined by the positive offset TI_REAC_WF_[CYL]:

$$TI_ADD_REAC_SCC_ [CYL] = TI_REAC_WF_ [CYL]$$

The additional injection quantity is reset after 2 x 720 °CRK.

Case 2 : Following cylinder fuel shut-off, the wall - applied fuel film has been totally removed.

The re-starting fuel quantity TI_ADD_REAC_SCC_[CYL] is performed with the maximum value possible with TI_REAC_WF_[CYL]:

$$TI_ADD_REAC_SCC_ [CYL] = TI_REAC_WF_ [CYL]$$

The re-starting fuel feed injection is reset after 3 x 720 °CRK.

Case 3 : It shows alternating cylinder operation.

An additional injection quantity is supplied every combustion cycle (720 °CRK).

Calibration data:

Name	Dim	Hex. limits	Phys. limits	Resol.	Unit
ID_TI_TCO_NEG_WF__TCO	8	0...FFFFH	0...3,9999	4 / 65536	-
Basic amount of wall - applied fuel film.					
ID_TI_TCO_POS_WF__TCO	8	0...FFFFH	0...3,9999	4 / 65536	-
Basic amount of fuel at fuel feed re-starting					
ID_TI_N_POS_RG__N_32	8	0...FFFFH	0...262,14	4 µsec	msec
First triggering fuel offset on re-start fuel feed for residual exhaust gas compensation.					
ID_TI_INC_WF__N_32	8	0...FFFFH	0...262,14	4 µsec	msec
Incrementation for wall - applied fuel film removing simulation.					
ID_TI_DEC_WF__N_32	8	0...FFFFH	0...262,14	4 µsec	msec
Fuel decrementation after re-starting fuel feed.					

Editor: Müller O.	17-Dec-97	Injection	HMC_V6
Version: a 153589 from 18.12.97		657765.49.06	
File: CHAP_7.DOC	650H0000	Sourcefile:07701901.00D	Page 69 / 121

1.3 Lambda control (A/F regulation loop)

1.3.1 General

The lambda control adjusts the air-fuel mixture applied to the engine to the stoichiometric ratio corresponding to $\lambda = 1$.

The lambda controller TI_LAM_i is a **P / I** controller. The reference variable for this controller is supplied by an exhaust gas probe, the oxygen sensor.

1.3.1.1 Conditions for lambda control

Output data:

Name	Mode	Hex. limits	Phys. limits	Resol.	Unit
LV_LSCL_i	V	0...01H	0...1	1	-
Boolean for close loop enabled for bank n° 1/2 - (OFF / ON).					
LV_LAM_ACT_i	V	0...01H	0...1	1	-
Boolean for lambda controller operability in its own limits for bank n° 1/2 - (Passive / Active).					
LV_LAM_i_READY	V	0...01H	0...1	1	-
Boolean for lambda controller non operability for bank n° 1/2 - (Passive / Active).					
LV_AUTH_LAM_CYCNR	V	0...01H	0...1	1	-
Boolean for lambda controller authorized again following A/F regulation in open loop - (Passive / Active).					

Input data:

LV_ES	LV_ST	LV_PUC	LV_FL
LV_TI_AST	LV_COP	LV_LEARN_CP	LV_SCC_LAM_ASR
LV_LSH_PHA_MAX_RATE	LV_IGA_AST	LV_AUTH_LAM_SA	LV_OPL_VS_MAX
LV_VLS_UP_i_ERR	LV_CPS_ERR	LV_DUR_IGC_[CYL]_ERR	LV_STATE_A_MIS
LV_TCO_ERR	LV_MAF_ERR	LV_LSH_UP_i_ERR	LV_IV_[CYL]_ERR
LV_CPS_ERR	LV_CPS_MECHA_ERR	LV_LAM_LIM_i_ERR	N_32
TI_LAM_i	MAF_KGH	TCO	TI_AD_FAC_MMV_i
LAM_MV_i	CPPWM	TI_AD_ADD_MMV_REL_i	LAM_MV_DYW_i
LV_AFR_i	C_T_MIN_LS	C_T_LAM_MAX_STATE	PAT_INH_IV
LV_LS_i	L_INH_IV_[CYL]		

Proprietary data, company confidential. All rights reserved.
 Contient des données confidentielles de la société. Tous droits réservés.
 Comunicado como secreto empresarial. Reservados todos los derechos.
 Confidado como secreto industrial. Nos reservamos todos los derechos.

Weitergabe sowie Vervielfältigung dieser Unterlage, Verwertung und Mitteilung ihres Inhalts nicht gestattet, soweit nicht ausdrücklich zugestanden. Zuwiderhandlungen verpflichten zu Schadensersatz. Alle Rechte vorbehalten, insbesondere für den Fall der Patenterteilung oder GM-Entragung.

Editor: Müller O.	17-Dec-97	Injection	HMC_V6
Version: a 153589 from 18.12.97		657765.49.06	
File: CHAP_7.DOC	650H0000	Sourcefile:07701B01.00E	Page 70 / 121

1.3.1.1.1 Closing conditions

Application conditions:

The conditions to close the A/F regulation loop for a cylinder bank n° i are :

```

If          LV_ES = 0                               (engine stopped inactive)
and         LV_ST = 0                               (engine operating state start inactive)
and         LV_LSH_PHA_MAX_RATE = 1                 (O2 sensor full rate heating phase finished)
and         LV_TI_AST = LV_IGA_AST = 0 (Passive)    (auxiliary function post start inactive)
and         LV_AUTH_LAM_SA = 0 (Passive)           (secondary air function inactive)
then
if          LV_VLS_UP_i_ERR = 0                    (no error currently present on O2 sensor signal acquisition)
and         LV_IV_[CYL]_ERR = 0                    (no error currently present on injection power stage)
and         LV_DUR_IGC_[CYL]_ERR = 0               (no error concerning the corresponding ignition output)
and         LV_STATE_A_MIS = 0                     (no misfire status CARB A (catalyst damage))
and         MAF_KGH > C_LAM_MAF_KGH_MIN_DIAG
or          LV_LSH_UP_i_ERR = 0                    (no error currently present on upstream O2-sensor heater power stage)
then
if          L_INH_IV_[CYL] = 0                     (no fuel shut-off)
and         PAT_INH_IV = 0                         (fuel shut-off pattern index state)
and         LV_SCC_LAM_ASR = 0                     (no ASR intervention)
and         LV_FL = 0 (Passive)                    (auxiliary function full load inactive)
and         LV_OPL_VS_MAX = 0 (Passive)            (no A/F regulation loop opened due to vehicle speed limitation)
then       C_LAM_CYCNR initialisation
    
```

Proprietary data, company confidential. All rights reserved.
 Contient des informations confidentielles. Tous droits réservés.
 Comunicado como secreto empresarial. Reservados todos os direitos.
 Confidado como secreto industrial. Nos reservamos todos los derechos.

Weitergabe sowie Veröffentlichung dieser Unterlage, Wertung und Mitteilung ihres Inhalts nicht gestattet, soweit nicht ausdrücklich zugestanden. Zuwiderhandlungen verpflichten zu Schadensersatz. Alle Rechte vorbehalten, insbesondere für den Fall der Patenterteilung oder GM-Enttragung.

Editor:	Müller O.	17-Dec-97	Injection	HMC_V6
Version:	a 153589 from 18.12.97		657765.49.06	
File:	CHAP_7.DOC	650H0000	Sourcefile:07701B01.00E	Page 71 / 121

Proprietary data, company confidential. All rights reserved.
 Contine a titre de secret d'entreprise. Tous droits réservés.
 Comunicado como segredo empresarial. Reservados todos os direitos.
 Confidado como secreto industrial. Nos reservamos todos los derechos.

```

If      N_32 > C_LAM_N_MIN
and    LV_AUTH_LAM_CYCNR = 0 (Passive)
          (timer C_LAM_CYCNR has elapsed after A/F regulation in open loop)
and    TCO > ID_TCO_LAM_MIN_IS__TCO_ST      in idle (LV_IS)
or     TCO > ID_TCO_LAM_MIN__TCO_ST        out of idle
          (condition checked only once)
then

if     LV_COP = 0 (Passive)
          (catalyst overheating prevention function inactive)
and    LV_LS_i = 1 (Active)
          (A/F regulation oxygen sensor operability
          effective)
or     C_T_MIN_LS expired
          (A/F regulation loop closed and LV_LS_i = 0)
then
    
```

LV_LSCL_i = 1 (ON) (A/F regulation loop closed)

Weitergabe sowie Vervielfältigung dieser Unterlage, Verwertung und Mitteilung ihres Inhalts nicht gestattet, soweit nicht ausdrücklich zugestanden. Zuwiderhandlungen verpflichten zu Schadensersatz. Alle Rechte vorbehalten, insbesondere für den Fall der Patenterteilung oder GM-Enttragung.

1.3.1.1.2 Lambda controller status definition following A/F regulation in open loop (LV_AUTH_LAM_CYCNR)

General information:

This boolean information (LV_AUTH_LAM_CYCNR) is used as condition for closing again the A/F regulation loop following the A/F regulation previously opened.

Application conditions:

The A/F regulation loop will be closed again when C_LAM_CYCNR seconds have been performed following the conditions to leave LV_LSCL_i = 0 (OFF).

Thus, the lambda controller will be authorized again only if N_32 > C_LAM_N_MIN.

Editor: Müller O.	17-Dec-97	Injection	HMC_V6
Version: a 153589 from 18.12.97		657765.49.06	
File: CHAP_7.DOC	650H0000	Sourcefile:07701B01.00E	Page 72 / 121

1.3.1.1.3 Lambda controller status definition relative to the A/F regulation loop (LV_LAM_ACT_i, LV_LAM_i_READY)

General information:

Two boolean information (LV_LAM_ACT_i and LV_LAM_i_READY) are built using the boolean information LV_LSCL_i relative to the A/F regulation loop.

- The first one (LV_LAM_ACT_i) indicates an A/F regulation loop closed and a lambda controller TI_LAM_i running in its own limitation.

- The second one (LV_LAM_i_READY) indicates the operability status of the lambda controller TI_LAM_i

Application conditions:

Activation:

if LV_LSCL_i = 1 (ON) (A/F regulation loop closed)
and LV_LAM_LIM_i_ERR = 1 (error currently present on lambda controller)
then LV_LAM_i_READY = 0 (Passive)

Deactivation :

if LV_LSCL_i = 0 (OFF) (A/F regulation loop opened)
or (LV_LSCL_i = 1 (ON) (A/F regulation loop closed)
and LV_AFR_i = 0 (Lean) → 1 (Rich)
or LV_AFR_i = 1 (Rich) → 0 (Lean)
and LV_LAM_LIM_i_ERR = 0)
 (no error currently present on lambda controller)
then LV_LAM_i_READY = 1 (Active)

Formula section:

if LV_LSCL_i = 1 (ON) (A/F regulation loop closed)
and LV_LAM_i_READY = 1 (Active) (lambda controller ready to operate)
then LV_LAM_ACT_i = 1 (Active)
else LV_LAM_ACT_i = 0 (Passive)

Proprietary data, company confidential. All rights reserved. Contine a titre de secret d'entreprise. Tous droits réservés. Comunicado como segredo empresarial. Reservados todos os direitos. Confidado como secreto industrial. Nos reservamos todos los derechos.

Weitergabe sowie Vervielfältigung dieser Unterlage, Verwertung und Mitteilung ihres Inhalts nicht gestattet, soweit nicht ausdrücklich zugestanden. Zuwiderhandlungen verpflichten zu Schadensersatz. Alle Rechte vorbehalten, insbesondere für den Fall der Patenterteilung oder GM-Entragung.

Editor: Müller O.	17-Dec-97	Injection	HMC_V6
Version: a 153589 from 18.12.97		657765.49.06	
File: CHAP_7.DOC	650H0000	Sourcefile:07701B01.00E	Page 73 / 121

1.3.1.1.4 Opening conditions

Application conditions:

The conditions to open the A/F regulation loop for a cylinder bank **n° i** are :

- If** LV_ES = 1 *(engine stopped active)*
- or** LV_ST = 1 *(engine operating state start active)*
- or** LV_LSH_PHA_MAX_RATE = 0 *(O2 sensor full rate heating phase not expired)*
- or** LV_TI_AST = 1 (Active) *(auxiliary function post start (TI correction) active)*
- or** LV_IGA_AST = 1 (Active) *(auxiliary function post start (IGA correction) active)*
- or** LV_AUTH_LAM_SA = 1 (Active) *(secondary air function active)*

then

LV_LSCL_i = 0 (OFF) *(A/F regulation loop opened)*

and

TI_LAM_i reaches its default value (**0** dec : **8000H**),
using the last **I** - component calculated.

else

- If** LV_VLS_UP_i_ERR = 1 *(error currently present on O2 sensor signal acquisition)*
- or** LV_IV_[CYL]_ERR = 1 *(error currently present on corresponding injection power stage)*
- or** LV_DUR_IGC_[CYL]_ERR = 1 *(error currently present on the corresponding ignition output)*
- or** LV_STATE_A_MIS = 1 *(misfire status CARB A (catalyst damage))*
- or** MAF_KGH ≤ C_LAM_MAF_KGH_MIN_DIAG **and** LV_LSH_UP_i_ERR = 1 *(error currently present on upstream O2 sensor heater power stage)*

then

LV_LSCL_i = 0 (OFF) *(A/F regulation loop opened)*

and

Proprietary data, company confidential. All rights reserved. Contine a titre de secret d'entreprise. Tous droits réservés. Comunicado como segredo empresarial. Reservados todos os direitos. Confidado como secreto industrial. Nos reservamos todos los derechos.

Weitergabe sowie Veröffentlichung dieser Unterlage, Wertung und Mitteilung ihres Inhalts nicht gestattet, soweit nicht ausdrücklich zugestanden. Zuwiderhandlungen verpflichten zu Schadenersatz. Alle Rechte vorbehalten, insbesondere für den Fall der Patenterteilung oder GM-Entragung.

Editor: Müller O.	17-Dec-97	Injection	HMC_V6
Version: a 153589 from 18.12.97		657765.49.06	
File: CHAP_7.DOC	650H0000	Sourcefile:07701B01.00E	Page 74 / 121

Proprietary data, company confidential. All rights reserved.
 Contient a titre de secret d'entreprise. Tous droits réservés.
 Comunicado como secreto empresarial. Reservados todos os direitos.
 Confidado como secreto industrial. Nos reservamos todos los derechos.

Weitergabe sowie Vervielfältigung dieser Unterlage, Verwertung und Mitteilung ihres Inhalts nicht gestattet, soweit nicht ausdrücklich zugestanden. Zuwiderhandlungen verpflichten zu Schadenersatz. Alle Rechte vorbehalten, insbesondere für den Fall der Patenterteilung oder GM-Entragung.

```

if      LV_MAF_ERR = 1
          (error currently present on mass air flow sensor)
or     LV_MAF_PLAUS_ERR = 1
          (error currently present on mass air flow signal)
or     LV_LAM_LIM_i_ERR = 1
          (error currently present on lambda controller)
or     LV_VLS_UP_i_ERR = 1
          (error currently present on O2 sensor signal acquisition)
or     LV_TCO_ERR = 1
          (error currently present on coolant temperature sensor)
or     LV_TCO_PLAUS_ERR = 1
          (error currently present on coolant temperature signal)
or     LV_CPS_ERR = 1
          (error currently present on evaporative emission control valve
          power stage)
or     LV_DUR_IGC_[CYL]_ERR = 1
          (error currently present on the corresponding ignition output)
or     LV_IV_[CYL]_ERR = 1
          (error currently present on corresponding injection power stage)
or     LV_STATE_A_MIS = 1
          (misfire status CARB A (catalyst damage))
or     LV_CPS_MECHA_ERR = 1
          (control valve mechanical error during evaporative system
          monitoring)
    
```

then

```

          TI_LAM_i_n = TI_LAM_i_n-1 + (TI_AD_FAC_MMV_i_n-1+ TI_AD_ADD_MMV_REL_i_n-1)
and
          LAM_MV_i_n = LAM_MV_i_n-1 + (TI_AD_FAC_MMV_i_n-1+ TI_AD_ADD_MMV_REL_i_n-1)
and
          LAM_MV_DYW_i_n = LAM_MV_DYW_i_n-1 + (TI_AD_FAC_MMV_i_n-1+ TI_AD_ADD_MMV_REL_i_n-1)
    
```

else

TI_LAM_i reaches its default value (**0 dec : 8000H**),
using the last I - component calculated.

else

Editor: Müller O.	17-Dec-97	Injection	HMC_V6
Version: a 153589 from 18.12.97		657765.49.06	
File: CHAP_7.DOC	650H0000	Sourcefile:07701B01.00E	Page 75 / 121

Proprietary data, company confidential. All rights reserved.
 Contient des informations confidentielles. Tous droits réservés.
 Comunicado como segredo empresarial. Reservados todos os direitos.
 Confidado como secreto industrial. Nos reservamos todos los derechos.

Weitergabe sowie Vervielfältigung dieser Unterlage, Verwertung und Mitteilung ihres Inhalts nicht gestattet, soweit nicht ausdrücklich zugestanden. Zuwiderhandlungen verpflichten zu Schadenersatz. Alle Rechte vorbehalten, insbesondere für den Fall der Patenterteilung oder GM-Entragung.

```

if          L_INH_IV_[CYL] = 1                (fuel shut-off active)
or         PAT_INH_IV ≠ 0                    (fuel shut-off pattern index)
or         LV_SCC_LAM_ASR = 1                (ASR intervention)
or         LV_FL = 1 (Active)                (auxiliary function full load active)
or         LV_OPL_VS_MAX = 1 (Active)        (A/F regulation loop opened due
                                                to VS limitation)
    
```

```

then
if          LV_LEARN_CP = 1
              (LEARNING mode from evaporative emission control in process (CPPWM ≠ 0))
then
              RAMP opening mode and LEARNING mode are aborted
and        C_T_LAM_MAX_STATE is started
else
    
```

```

LV_LSCL_i = 0 (OFF)                (A/F regulation loop opened)
    
```

```

and        C_LAM_CYCNR is initialized
and
    
```

```

if          LV_PUC = 1                (trailing throttle fuel cut-off active)
then        TI_LAM_i = 0 dec. ( 8000H )
    
```

```

Endif
    
```

```

else
if          N_32 ≤ C_LAM_N_MIN
or         C_LAM_CYCNR not expired
or         TCO ≤ ID_TCO_LAM_MIN_IS__TCO_ST in idle (LV_IS)
or         TCO ≤ ID_TCO_LAM_MIN__TCO_ST out of idle
then
    
```

```

LV_LSCL_i = 0 (OFF)                (A/F regulation loop opened)
    
```

```

and
    
```

```

TI_LAM_i reaches its default value (0 dec : 8000H),
using the last I - component calculated.
    
```

Calibration data:

Name	Dim	Hex. limits	Phys. limits	Resol.	Unit
ID_TCO_LAM_MIN_IS__TCO_ST	6	0...FEH	-48...142,5	0,75	°C
Minimum coolant temperature to close the A/F regulation loop in idle.					
ID_TCO_LAM_MIN__TCO_ST	6	0...FEH	-48...142,5	0,75	°C
Minimum coolant temperature to close the A/F regulation loop out of idle					
C_LAM_N_MIN	1	0...FFH	0...8160	32	rpm
Minimum engine speed to close the A/F regulation loop.					
C_LAM_MAF_KGH_MIN_DIAG	1	0...FFFFH	0...16383,75	0,25	kg/h
Minimum mass air flow threshold for validation of the upstream O2 sensor heater power stage.					
C_LAM_CYCNR	1	01...FFFFH	0,01...655,35	0,01	sec
Authorization delay for closing again the A/F regulation loop following A/F regulation loop opened.					

Editor: Müller O.	17-Dec-97	Injection	HMC_V6
Version: a 153589 from 18.12.97		657765.49.06	
File: CHAP_7.DOC	650H0000	Sourcefile:07701B01.00E	Page 76 / 121

1.3.2 Variables related to A/F regulation oxygen sensors signal voltages (VLS_i)

Output data:

Name	Mode	Hex. limits	Phys. limits	Resol.	Unit
VLS_MMV_MAX_i	V	0...FFH	0...4,9805	5 / 256	V.
Moving mean maximum oxygen sensor n° 1 voltage.					
VLS_MMV_MIN_i	V	0...FFH	0...4,9805	5 / 256	V.
Moving mean minimum oxygen sensor n° 1 voltage.					
VLS_TOL_i	V	0...FFH	0...4,9805	5 / 256	V.
VLS_MMV_MIN_i corrected voltage.					
VLS_BOL_i	V	0...FFH	0...4,9805	5 / 256	V.
VLS_MMV_MAX_i corrected voltage.					

Input data:

VLS_i	TI_LAM_i	LV_ES	TCO
LV_LS_i	LV_VLS_UP_i_ERR	LV_FL	LV_LSCL_i
LV_LAM_ACT_i			

FUNCTION DESCRIPTION:

General information:

The different variables are calculated using the oxygen sensor voltage VLS_i in order to :

- define the lean / rich thresholds
- manage the A/F regulation oxygen sensor heater controller.

Remark : **i = 1** for injection bank n° 1
i = 2 for injection bank n° 2

Application recurrence : **20 msec.**

Formula section:

* *Initialisation :*

```

If          engine stopped (LV_ES) active
and        TCO ≥ C_LAM_TCO_VLS_MIN_INI
then       VLS_MMV_MAX_i = VLS_MMV_MIN_i = VLS_TOL_i = VLS_BOL_i
              = C_VLS_INI_MIN
else       VLS_MMV_MAX_i = VLS_MMV_MIN_i = VLS_TOL_i = VLS_BOL_i
              = C_VLS_INI
    
```

Proprietary data, company confidential. All rights reserved. Contient des informations confidentielles. Tous droits réservés. Comunicado como segredo empresarial. Reservados todos os direitos. Confidado como secreto industrial. Nos reservamos todos los derechos.

Weitergabe sowie Vervielfältigung dieser Unterlage, Verwertung und Mitteilung ihres Inhalts ist gestattet, soweit nicht ausdrücklich zugestanden. Zuwiderhandlungen verpflichten zu Schadenersatz. Alle Rechte vorbehalten, insbesondere für den Fall der Patenterteilung oder GM-Entragung.

Editor: Müller O.	17-Dec-97	Injection	HMC_V6
Version: a 153589 from 18.12.97		657765.49.06	
File: CHAP_7.DOC	650H0000	Sourcefile:07701C03.00F	Page 77 / 121

* Calculation :

```

if engine stopped (LV_ES) not active
    and LV_VLS_UP_i_ERR = 0 (no error currently present on oxygen
        sensor signal acquisition)
    then
        if LV_LS_i = 0 (oxygen sensor non operability for A/F
            regulation)
            then no calculation
            else
                if VLS_TOL_i ≤ VLS_i ≤ VLS_BOL_i
                    (case n° 2 - refer to the following " Description ")
                    or LV_LAM_ACT_i = 0
                    (the condition for lambda controller active (LV_LSCL_i = 1)
                    and injection time correction ( TI_LAM_i ) not on limit is not
                    fulfilled)
                    then no calculation
                    else
                        if VLS_i < VLS_TOL_i
                            (case n° 1 - refer to the following " Description ")
                            then
    
```

$$VLS_MMV_MIN_i_n = VLS_MMV_MIN_i_{n-1} * (1 - C_VLS_CRLC) + VLS_i_n * C_VLS_CRLC$$

$$VLS_TOL_i_n = VLS_MMV_MIN_i_n + C_VLS_MMV_HYS$$

```

    else
        if VLS_i > VLS_BOL_i
            (case n° 3 - refer to the following " Description ")
            then
    
```

$$VLS_MMV_MAX_i_n = VLS_MMV_MAX_i_{n-1} * (1 - C_VLS_CRLC) + VLS_i_n * C_VLS_CRLC$$

$$VLS_BOL_i_n = VLS_MMV_MAX_i_n - C_VLS_MMV_HYS$$

(special treatment in case of full load detection (LV_FL))

```

    if VLS_BOL_i ≤ VLS_TOL_i
    then
    
```

$$VLS_BOL_i = VLS_TOL_i = (VLS_MMV_MAX_i + VLS_MMV_MIN_i) / 2$$

Editor: Müller O.	17-Dec-97	Injection	HMC_V6
Version: a 153589 from 18.12.97		657765.49.06	
File: CHAP_7.DOC	650H0000	Sourcefile:07701C03.00F	Page 78 / 121

* Special treatment in case of full load detection :

In this case, VLS_MMV_MAX_i cannot be calculated and a correction is made on VLS_BOL_i determination after leaving full load operation.

If LV_FL = 1 (FL) during at least C_T_VLS_FL seconds
then when exiting (LV_FL)
 $VLS_BOL_i_n = VLS_BOL_i_{n-1} - C_VLS_SUBT_BOL_FL$

(C_VLS_SUBT_BOL_FL will be removed using change limitation
 C_VLS_LGRD_DEC_FL)

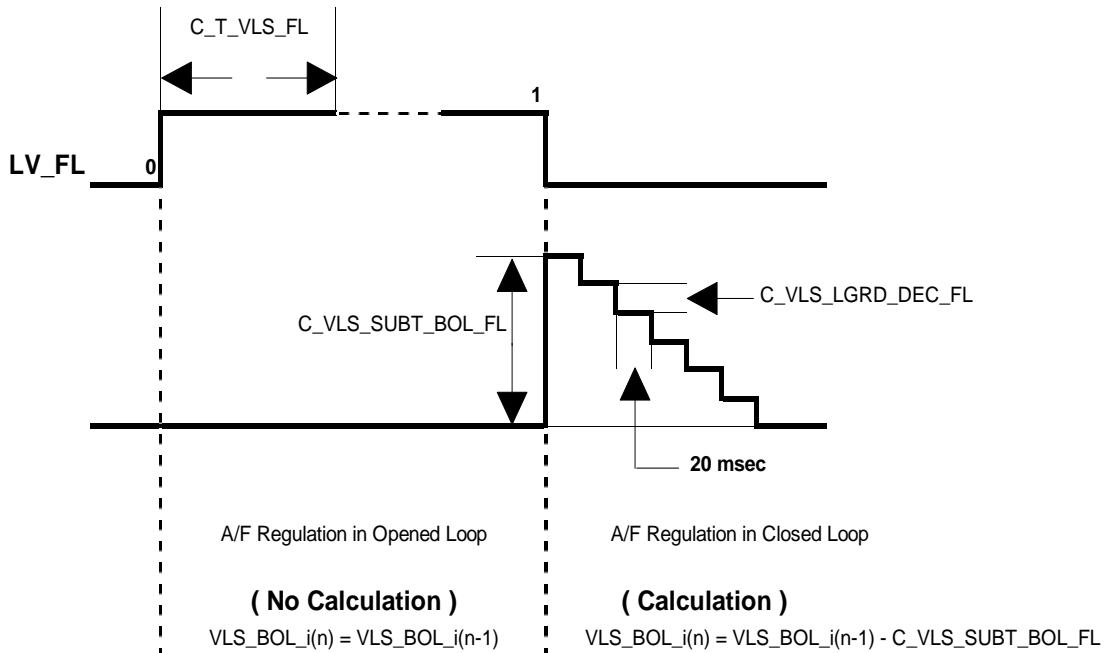

Proprietary data, company confidential. All rights reserved. Contine a titre de secret d'entreprise. Tous droits réservés. Comunicado como segredo empresarial. Reservados todos os direitos. Confidado como secreto industrial. Nos reservamos todos los derechos.

Weitergabe sowie Veröffentlichung dieser Unterlage, Verwertung und Mitteilung ihres Inhalts nicht gestattet, soweit nicht ausdrücklich zugestanden. Zuwiderhandlungen verpflichten zu Schadensersatz. Alle Rechte vorbehalten, insbesondere für den Fall der Patenterteilung oder GM-Eintragung.

Editor: Müller O.	17-Dec-97	Injection	HMC_V6
Version: a 153589 from 18.12.97		657765.49.06	
File: CHAP_7.DOC	650H0000	Sourcefile:07701C03.00F	Page 79 / 121

Description:

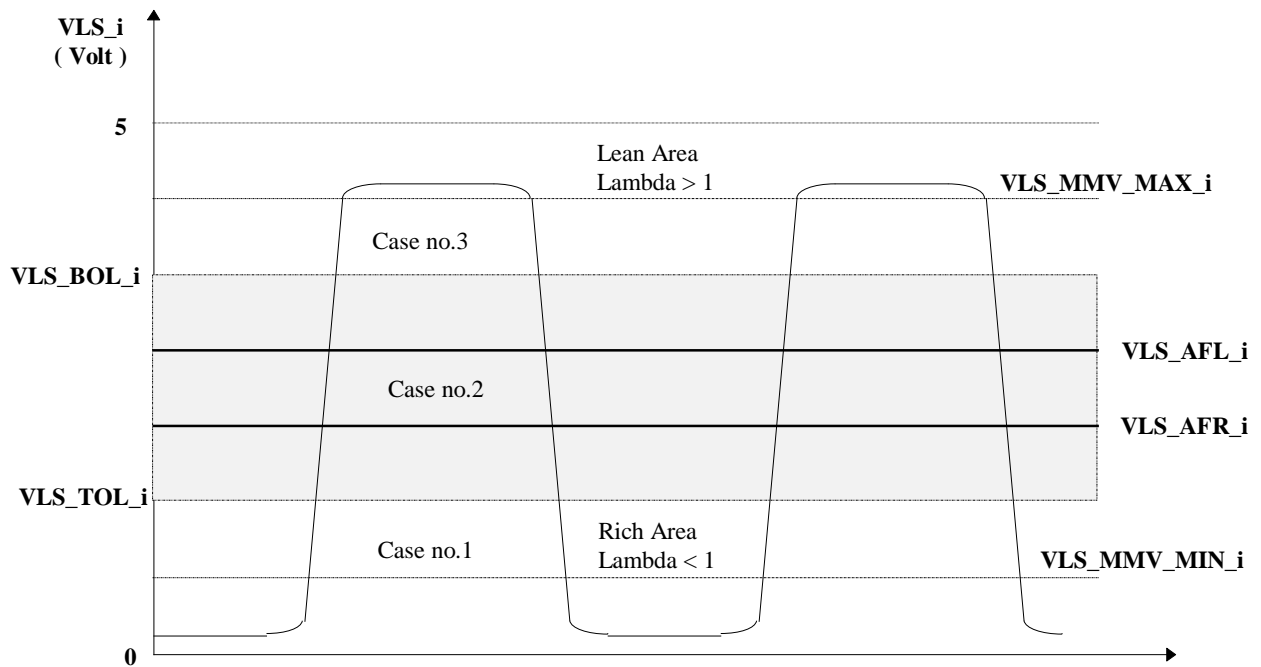

Proprietary data, company confidential. All rights reserved. Contine a titre de secret d'entreprise. Tous droits réservés. Comunicado como segredo empresarial. Reservados todos os direitos. Confidado como secreto industrial. Nos reservamos todos los derechos.

Weitergabe sowie Vervielfältigung dieser Unterlage, Verwertung und Mitteilung ihres Inhalts nicht gestattet, soweit nicht ausdrücklich zugestanden. Zuwiderhandlungen verpflichten zu Schadenersatz. Alle Rechte vorbehalten, insbesondere für den Fall der Patenterteilung oder GM-Entragung.

Calibration data:

Name	Dim	Hex. limits	Phys. limits	Resol.	Unit
C_LAM_TCO_VLS_MIN_INI	1	0...FFH	-48...142,5	0,75	°C
Coolant temperature threshold for initialisation of the variables related to AF regulation oxygen sensors signal voltages.					
C_VLS_INI_MIN	1	0...FFH	0...4,9805	5 / 256	V.
Initialization of VLS_MMV_MAX_i, VLS_MMV_MIN_i, VLS_BOL_i, VLS_TOL_i depending on coolant temperature threshold.					
C_VLS_INI	1	0...FFH	0...4,9805	5 / 256	V.
Initialization of VLS_MMV_MAX_i, VLS_MMV_MIN_i, VLS_BOL_i, VLS_TOL_i depending on coolant temperature threshold.					
C_VLS_CRLC	1	00...FFH	0...0,997	3,895E-3	-
Correlation factor for VLS_MMV_MAX_i and VLS_MMV_MIN_i calculation.					
C_VLS_MMV_HYS	1	0...FFH	0...4,9805	5 / 256	V.
Hysteresis for VLS_TOL_i and VLS_BOL_i calculation.					
C_T_VLS_FL	1	01...FFH	1...255	1	sec.
Minimum duration of full load (LV_FL) for VLS_BOL_i correction application.					
C_VLS_SUBT_BOL_FL	1	0...FFH	0...4,9805	5 / 256	V.
Offset applied on VLS_BOL_i calculation when exiting from full load (LV_FL).					
C_VLS_LGRD_DEC_FL	1	01...FFH	0,0195...4,9805	5 / 256	V.
Change limitation for C_VLS_SUBT_BOL_FL removing.					

Editor: Müller O.	17-Dec-97	Injection	HMC_V6
Version: a 153589 from 18.12.97		657765.49.06	
File: CHAP_7.DOC	650H0000	Sourcefile:07701C03.00F	Page 80 / 121

1.3.2.1 Rich and lean mixture voltage thresholds (VLS_AFR_i, VLS_AFL_i)

Output data:

Name	Mode	Hex. limits	Phys. limits	Resol.	Unit
VLS_AFR_i	V	0...FFH	0...4,9805	5 / 256	V.
Oxygen sensor voltage threshold for rich mixture detection.					
VLS_AFL_i	V	0...FFH	0...4,9805	5 / 256	V.
Oxygen sensor voltage threshold for lean mixture detection.					
LV_AFR_i	V	0...01H	0...1	1	-
Boolean for A/F ratio state for oxygen sensor i - (Lean / Rich).					

Input data:

VLS_MMV_MIN_i	VLS_MMV_MAX_i	C_LAM_TCO_VLS_MIN_INI	TCO
VLS_i	LV_VLS_LIM_i_ERR	C_VLS_INI	C_VLS_INI_MIN
LV_VLS_UP_i_ERR			

FUNCTION DESCRIPTION:

General information:

Application recurrence : **20 msec.**

Formula section:

* *Initialisation :*

If engine stopped (LV_ES) active
and $TCO \geq C_LAM_TCO_VLS_MIN_INI$
then $VLS_AFR_i = VLS_AFL_i = C_VLS_INI_MIN$
else $VLS_AFR_i = VLS_AFL_i = C_VLS_INI$

* *Calculation :*

The calculation is performed as soon as all the conditions for calculation of the variables related to A/F regulation oxygen sensor signal voltage are met.

If $LV_VLS_LIM_i_ERR = 0$
(no error currently present on oxygen sensor signal voltage excursion diagnosis)
and $LV_VLS_UP_i_ERR = 0$
(no error currently present on oxygen sensor signal voltage diagnosis)
then

$$VLS_AFR_i = VLS_MMV_MIN_i + (VLS_MMV_MAX_i - VLS_MMV_MIN_i) * C_VLS_FAC_AFR$$

$$VLS_AFL_i = VLS_MMV_MIN_i + (VLS_MMV_MAX_i - VLS_MMV_MIN_i) * C_VLS_FAC_AFL$$

Editor: Müller O.	17-Dec-97	Injection	HMC_V6
Version: a 153589 from 18.12.97		657765.49.06	
File: CHAP_7.DOC	650H0000	Sourcefile:07701C03.00F	Page 81 / 121

* Rich or Lean mixture detection :

If { LV_AFR_i = 1 (Rich) **and** VLS_i > VLS_AFL_i }
then LV_AFR_i = 0 (Lean) → Lambda > 1

If { LV_AFR_i = 0 (Lean) **and** VLS_i < VLS_AFR_i }
then LV_AFR_i = 1 (Rich) → Lambda < 1

Description:

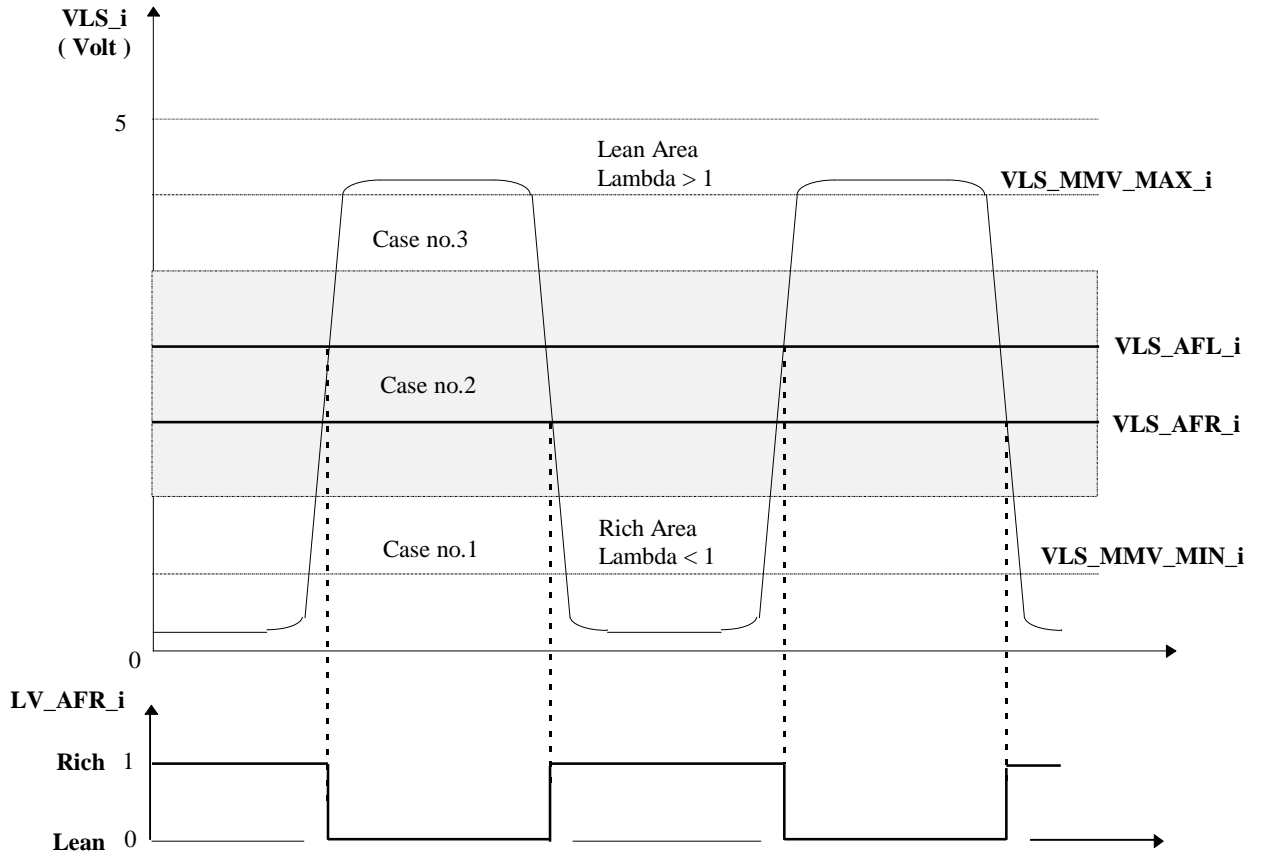

Calibration data:

Name	Dim	Hex. limits	Phys. limits	Resol.	Unit
C_VLS_FAC_AFR	1	00...FFH	0...0,997	3,895E-3	-
Weighting factor to calculate oxygen sensors signal voltages VLS_AFR_i for rich mixture detection.					
C_VLS_FAC_AFL	1	00...FFH	0...0,997	3,895E-3	-
Weighting factor to calculate oxygen sensors signal voltages VLS_AFL_i for lean mixture detection.					

Editor: Müller O.	17-Dec-97	Injection	HMC_V6
Version: a 153589 from 18.12.97		657765.49.06	
File: CHAP_7.DOC	650H0000	Sourcefile:07701C03.00F	Page 82 / 121

Proprietary data, company confidential. All rights reserved.
 Contient des données confidentielles de la société. Tous droits réservés.
 Comunicado como secreto empresarial. Reservados todos los derechos.
 Confiado como secreto industrial. Nos reservamos todos los derechos.

Weitergabe sowie Vervielfältigung dieser Unterlage, Verwertung und Mitteilung ihres Inhalts ist nicht gestattet, soweit nicht ausdrücklich zugestanden. Zuwiderhandlungen verpflichten zu Schadensersatz. Alle Rechte vorbehalten, insbesondere für den Fall der Patenterteilung oder GM-Eintragung.

1.3.2.2 A/F regulation oxygen sensors operability (LV_LS_i)

Output data:

Name	Mode	Hex. limits	Phys. limits	Resol.	Unit
LV_LS_i	V	0...01H	0...1	1	-
Boolean for A/F regulation oxygen sensor operability - (0 / 1).					

Input data:

LV_ES	TCO	LV_VLS_LIM_i_ERR	LV_VLS_UP_i_ERR
TI_LAM_i	C_VLS_INI	C_LAM_MAX	C_VLS_INI_MIN
C_LAM_TCO_VLS_MIN_INI			

FUNCTION DESCRIPTION:

General information:

In engine operating state engine stopped (LV_ES), the A/F regulation oxygen sensors are initialized to non operable condition (LV_LS_i = 0).

As soon as the engine operating state engine stopped is exited, the system checks whether the oxygen sensors signal voltages have dropped below a voltage threshold.

Application recurrence : **20 msec.**

Formula section:

* *Non operability :*

If engine stopped (LV_ES) active
or LV_VLS_LIM_i_ERR = 1
 (error currently present on oxygen sensor signal voltage excursion diagnosis)
then LV_LS_i = 0

* *Operability :*

If engine stopped (LV_ES) not active
and LV_VLS_UP_i_ERR = 0
 (no error currently present on oxygen sensors signal voltages acquisition diagnosis)
and VLS_i signal voltage has dropped below :
or C_VLS_INI **if** TCO < C_LAM_TCO_VLS_MIN_INI
 C_VLS_INI_MIN **if** TCO ≥ C_LAM_TCO_VLS_MIN_INI
then LV_LS_i = 1

Proprietary data, company confidential. All rights reserved. Contine a titre de secret d'entreprise. Tous droits réservés. Comunicado como segredo empresarial. Reservados todos os direitos. Confidado como secreto industrial. Nos reservamos todos los derechos.

Weitergabe sowie Vervielfältigung dieser Unterlage, Verwertung und Mitteilung ihres Inhalts ist gestattet, soweit nicht ausdrücklich zugestanden. Zuwiderhandlungen verpflichten zu Schadensersatz. Alle Rechte vorbehalten, insbesondere für den Fall der Patenterteilung oder GM-Enttragung.

Editor: Müller O.	17-Dec-97	Injection	HMC_V6
Version: a 153589 from 18.12.97		657765.49.06	
File: CHAP_7.DOC	650H0000	Sourcefile:07701C03.00F	Page 83 / 121

Remark : Special treatment if LV_LSCL_i = 1 (ON) and LV_LS_i = 0 (Passive)

If one of the oxygen sensor is not operable (LV_LS_i = 0) when the timer C_T_MIN_LS has elapsed (C_T_MIN_LS starts when the preliminary heating phase for oxygen sensor is finished) and if the A/F regulation loop is authorized to be closed, then the corresponding lambda controller TI_LAM_i is started with the maximum limit C_LAM_INI_MAX instead of C_LAM_MAX

Following the first lean to rich transition of the corresponding oxygen sensor, this limit is set again to C_LAM_MAX and LV_LS_i = 1 (Active).

The condition $C_LAM_INI_MAX \leq C_LAM_MAX$ must be met.

Calibration data:

Name	Dim	Hex. limits	Phys. limits	Resol.	Unit
C_T_MIN_LS	1	01...FFH	1...255	1	sec
Minimum duration before closing the A/F regulation loop if the oxygen sensors are not ready.					
C_LAM_INI_MAX	1	8000...D000H	0...31,25	100 / 65536	%
Maximum value of the lambda controller TI_LAM_i when LV_LSCL_i = 1 (ON) and LV_LS_i = 0 (Passive).					

Proprietary data, company confidential. All rights reserved. Contine a titre de secret d'entreprise. Tous droits réservés. Comunicado como secreto empresarial. Reservados todos os direitos. Confidado como secreto industrial. Nos reservamos todos los derechos.

Weitergabe sowie Vervielfältigung dieser Unterlage, Wertung und Mitteilung ihres Inhalts nicht gestattet, soweit nicht ausdrücklich zugestanden. Zuwiderhandlungen verpflichten zu Schadensersatz. Alle Rechte vorbehalten, insbesondere für den Fall der Patenterteilung oder GM-Entragung.

Editor: Müller O.	17-Dec-97	Injection	HMC_V6
Version: a 153589 from 18.12.97		657765.49.06	
File: CHAP_7.DOC	650H0000	Sourcefile:07701C03.00F	Page 84 / 121

1.3.3 Variables related to A/F regulation oxygen sensors heater (LSHPWM_i)

Output data:

Name	Mode	Hex. limits	Phys. limits	Resol.	Unit
LSHPWM_i	V	00...FFH	0...99.609	0.3891	%
Upstream oxygen sensors heating duty cycle.					
LSHPWM_LGRD_i	V	0...FFFFH	0...99.6	0.0015	%
Basic upstream oxygen sensors heating duty cycle with gradient limitation.					
VLS_DIF_i	V	0...FFH	-5...4.9609	10 / 256	V.
Variable representative of the upstream oxygen sensors tip-temperature.					
LSHPWM_FAC_i	V	00...FFH	0...1.992	7.782E-3	-
Upstream oxygen sensors heater controller.					
LSHPWM_CYCNR	V	0...FFH	0...65535	1	-
Time delay for limited heating after Start (LV_ST).					
LV_LSH_PHA_AST	V	0...01H	0...1	1	-
Boolean for oxygen sensor preliminary heating phase (after start).					
LV_LSH_PHA_MAX_RATE	V	0...01H	0...1	1	-
Boolean for oxygen sensor full rate heating phase.					

Input data:

LV_ES	LV_ST	LV_PUC	TIA_ST
VLS_MMV_MAX_i	LV_LS_i	LV_LAM_ACT_i	TI_LAM_i
VLS_MMV_MIN_i	LV_LSH_UP_i_ERR	LV_VB_JUMP	C_T_MIN_LS
MAF_KGH	VB	C_VB_MIN_JUMP	N_32
MAF	TCO_ST		

FUNCTION DESCRIPTION:

General information:

The control of each heater is performed individually.

In order to avoid big temperature gradients after start, the oxygen sensors are heated preliminary => factor applied on the normal heating.

Following this pre-heating phase, the sensors are fully heated in order to reach their service temperature.

Then, the normal duty cycles LSHPWM_i are based on:

- a pre-control value (cylinder bank individual) weighted by battery voltage
- a heater controller (cylinder bank individual) based on the moving mean minimum and maximum oxygen sensors voltages.

- Application recurrence :

- Engine stopped: **100 msec.** to start pre-heating phase
- Engine running: **1 sec.** for pre-heating phase duration
- C_T_PER_LSH sec.** for LSHPWM_i calculation

Editor: Müller O.	17-Dec-97	Injection	HMC_V6
Version: a 153589 from 18.12.97		657765.49.06	
File: CHAP_7.DOC	650H0000	Sourcefile:07701D01.00H	Page 85 / 121

Proprietary data, company confidential. All rights reserved.
 Contient des données confidentielles. Tous droits réservés.
 Comunicado como segredo empresarial. Reservados todos os direitos.
 Confidado como secreto industrial. Nos reservamos todos los derechos.

Weitergabe sowie Vervielfältigung dieser Unterlage, Verwertung und Mitteilung ihres Inhalts ist gestattet, soweit nicht ausdrücklich zugestanden. Zuwiderhandlungen verpflichten zu Schadensersatz. Alle Rechte vorbehalten, insbesondere für den Fall der Patenterteilung oder GM-Entragung.

1.3.3.1 Initialization

Application conditions:

If engine stopped (LV_ES) active
or LV_VB_JUMP = 1 (Active) (battery over voltage at start detected)
then LSHPWM_i = NC_LSHPWM_MIN_DIAG
and LSHPWM_FAC_i = C_LSHPWM_FAC_INI
and LSHPWM_CYCNR = 0
and A/F regulation - P jump counter (C_LSHPWM_LAM_P_SUM_FAC) is reset.

Remark :

Following over voltage event (LV_VB_JUMP = 1 (Active) → 0 (Passive)) detected at start, the oxygen sensor preliminary heating phase is performed again.

1.3.3.2 Oxygen sensors duty cycle gradient limitation (LSHPWM_LGRD_i)

General information:

The target duty cycle LSHPWM_i to be applied to the oxygen sensor heater is:

$$LSHPWM_LGRD_i = IP_LSHPWM_i_N_32_MAF * IP_LSHPWM_VB_FAC_VB$$

If the engine operating point (N_32, MAF) or VB change, a gradient limitation is applied to the previous value to reach the new value.

If the new value is lower, then IP_LSHPWM_LGRD_NEG_MAF_KGH is used; else if the new value is higher, then IP_LSHPWM_LGRD_POS_MAF_KGH is used.

Therefore, the internal variable LSHPWM_LGRD_i is used temporary by the software for calculation of the duty cycle LSHPWM_i.

At transition engine stop (LV_ES) to engine start (LV_ST) LSHPWM_LGRD_i is initialized with C_LSHPWM_INI_i :

$$LSHPWM_LGRD_i = C_LSHPWM_INI_i$$

Description:

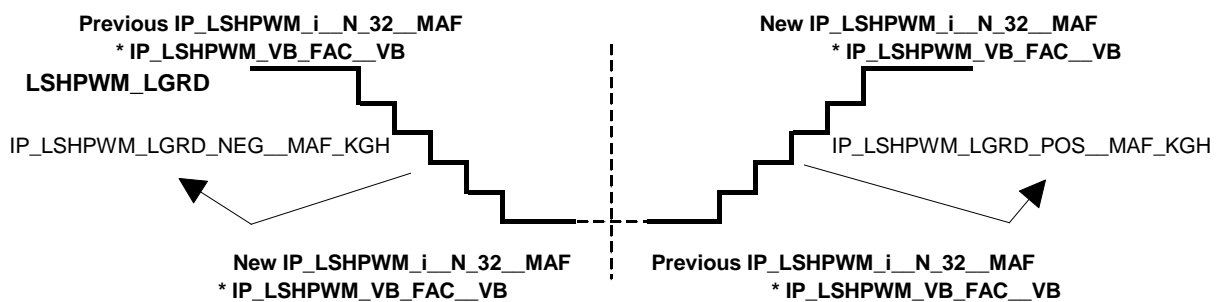

Editor: Müller O.	17-Dec-97	Injection	HMC_V6
Version: a 153589 from 18.12.97		657765.49.06	
File: CHAP_7.DOC	650H0000	Sourcefile:07701D01.00H	Page 86 / 121

Proprietary data, company confidential. All rights reserved.
 Contient des informations confidentielles. Tous droits réservés.
 Comunicado como secreto empresarial. Reservados todos los derechos.
 Confidado como secreto industrial. Nos reservamos todos los derechos.

Weitergabe sowie Veröffentlichung dieser Unterlage, Verwertung und Mitteilung ihres Inhalts nicht gestattet, soweit nicht ausdrücklich zugestanden. Zuwiderhandlungen verpflichten zu Schadensersatz. Alle Rechte vorbehalten, insbesondere für den Fall der Patenterteilung oder GM-Enttragung.

1.3.3.3 Oxygen sensors preliminary heating phase (LV_LSH_PHA_AST)

Application conditions:

Activation:

if LV_ES → LV_ST
 (transition from engine stopped to start)
or LV_VB_JUMP = 1 (Active) → 0 (Passive)
 (battery over voltage at start removed)
then LSHPWM_CYCNR = IP_LSHPWM_CYCNR__TIA_ST
 (timer initialization)

$$LSHPWM_CYCNR_n = LSHPWM_CYCNR_{n-1} - IP_DEC_CYCNR_LSH_MAF_KGH$$

(timer decrementation)

and

$$LSHPWM_i = LSHPWM_LGRD_i * C_LSHPWM_T_FAC + C_LSHPWM_i_AS$$

Remark :

During oxygen sensor preliminary heating phase, the weighting factor LSHPWM_FAC_i (calculation of LSHPWM_i in basis heating phase) is kept with its initialization value C_LSHPWM_FAC_INI.

- *Deactivation :*

if engine stopped (LV_ES) detected
or LV_VB_JUMP = 0 (Passive) → 1 (Active)
or LSHPWM_CYCNR = 0
then LV_LSH_PHA_AST = 1

- *Limitation :*

$$NC_LSHPWM_MIN_DIAG \leq LSHPWM_i \leq NC_LSHPWM_MAX_DIAG$$

Proprietary data, company confidential. All rights reserved. Contine a titre de secret d'entreprise. Tous droits réservés. Comunicado como segredo empresarial. Reservados todos os direitos. Confidado como secreto industrial. Nos reservamos todos los derechos.

Weitergabe sowie Vervielfältigung dieser Unterlage, Verwertung und Mitteilung ihres Inhalts nicht gestattet, soweit nicht ausdrücklich zugestanden. Zuwiderhandlungen verpflichten zu Schadensersatz. Alle Rechte vorbehalten, insbesondere für den Fall der Patenterteilung oder GM-Entragung

Editor: Müller O.	17-Dec-97	Injection	HMC_V6
Version: a 153589 from 18.12.97		657765.49.06	
File: CHAP_7.DOC	650H0000	Sourcefile:07701D01.00H	Page 87 / 121

1.3.3.4 Oxygen sensors full rate heating phase (LV_LSH_PHA_MAX_RATE)

Application conditions:

Activation:

if LV_LSH_PHA_AST = 0 → 1
then the timer IP_T_MAX_LSH_ST__TCO_ST is started
and the timer C_T_MIN_LS is started
 (refer to chapter“ A/F regulation oxygen sensors operability (LV_LS_i) “)
and

LSHPWM_i = NC_LSHPWM_MAX_DIAG

Deactivation:

if IP_T_MAX_LSH_ST__TCO_ST has elapsed
then LV_LSH_PHA_MAX_RATE = 1
and A/F regulation - P jump counter
 (C_LSHPWM_LAM_P_SUM_FAC) initialized.
and

LSHPWM_i = LSHPWM_LGRD_i + C_LSHPWM_i_AS

(without weighting factor C_LSHPWM_T_FAC).

1.3.3.5 Oxygen sensors heater controller

1.3.3.5.1 A/F regulation in open loop (LV_LSCL_i = 0 (OFF))

if LV_LAM_ACT_i = 0 (Passive)
 (*lambda controller TI_LAM_i not ready to operate*)
or LV_LSH_i_ERR = 1
 (*error currently present on upstream oxygen sensor heater power stage*)
or A/F regulation - P jump counter
 (C_LSHPWM_LAM_P_SUM_FAC) in process
or LSHPWM_LGRD_i < NC_LSHPWM_LGRD_MIN
then the weighting factor LSHPWM_FAC_i of the heater controller
 LSHPWM_i reaches the default value 1 using change limitation
 C_LSHPWM_DIF_PUC

Proprietary data, company confidential. All rights reserved.
 Contine a titre de secret d'entreprise. Tous droits réservés.
 Comunicado como segredo empresarial. Reservados todos os direitos.
 Confidado como secreto industrial. Nos reservamos todos los derechos.

Weitergabe sowie Vervielfältigung dieser Unterlage, Verwertung und Mitteilung ihres Inhalts nicht gestattet, soweit nicht ausdrücklich zugestanden. Zuwiderhandlungen verpflichten zu Schadensersatz. Alle Rechte vorbehalten, insbesondere für den Fall der Patenterteilung oder GM-Entragung.

Editor: Müller O.	17-Dec-97	Injection	HMC_V6
Version: a 153589 from 18.12.97		657765.49.06	
File: CHAP_7.DOC	650H0000	Sourcefile:07701D01.00H	Page 88 / 121

1.3.3.5.2 AF regulation in closed loop (LV_LSCL_i = 1 (ON))

if LV_LAM_ACT_i = 1 (Active)
(A/F regulation loop closed and lambda controller TI_LAM_i running)
and LV_LSH_UP_i_ERR = 0
(no error currently present on upstream oxygen sensor heater power stage)
and A/F regulation - P jump counter
 (C_LSHPWM_LAM_P_SUM_FAC) has reached 0
and LSHPWM_LGRD_i ≥ NC_LSHPWM_LGRD_MIN
then

$$VLS_DIF_i = (VLS_MMV_MAX_i + VLS_MMV_MIN_i) - C_VLS_SP$$

(representative value of oxygen sensor probe temperature)

and

if VLS_DIF_i < 0
then LSHPWM_FAC_i_n = LSHPWM_FAC_i_n-1 - IP_LSHPWM_DIF_I_i_VLS_DIF_i
if VLS_DIF_i > 0
then LSHPWM_FAC_i_n = LSHPWM_FAC_i_n-1 + IP_LSHPWM_DIF_I_i_VLS_DIF_i

Remark :

- *Limitation :*

$$C_LSHPWM_FAC_MIN \leq LSHPWM_FAC_i \leq C_LSHPWM_FAC_MAX$$

Formula section:

- *Duty cycle LSHPWM_i calculation :*

$$LSHPWM_i = LSHPWM_LGRD_i * LSHPWM_FAC_i + C_LSHPWM_i_AS$$

Remark :

- If LSHPWM_i reaches the maximum value, then the last calculated LSHPWM_FAC_i component is maintained while the heater controller moves in the opening direction.
- If LSHPWM_i reaches the minimum value, then the last calculated LSHPWM_FAC_i component is maintained while the heater controller moves in the closing direction.

Proprietary data, company confidential. All rights reserved. Contient a titre de secret d'entreprise. Tous droits réservés. Comunicado como segredo empresarial. Reservados todos os direitos. Confidado como secreto industrial. Nos reservamos todos los derechos.

Weitergabe sowie Vervielfältigung dieser Unterlage, Verwertung und Mitteilung ihres Inhalts nicht gestattet, soweit nicht ausdrücklich zugestanden. Zuwiderhandlungen verpflichten zu Schadensersatz. Alle Rechte vorbehalten, insbesondere für den Fall der Patenterteilung oder GM-Entragung.

Editor: Müller O.	17-Dec-97	Injection	HMC_V6
Version: a 153589 from 18.12.97		657765.49.06	
File: CHAP_7.DOC	650H0000	Sourcefile:07701D01.00H	Page 89 / 121

Description:

Proprietary data, company confidential. All rights reserved.
 Contient des informations confidentielles. Tous droits réservés.
 Comunicado como secreto empresarial. Reservados todos os direitos.
 Confidado como secreto industrial. Nos reservamos todos los derechos.

Weitergabe sowie Vervielfältigung dieser Unterlage, Verwertung und Mitteilung ihres Inhalts ist gestattet, soweit nicht ausdrücklich zugestanden. Zuwiderhandlungen verpflichten zu Schadensersatz. Alle Rechte vorbehalten, insbesondere für den Fall der Patenterteilung oder GM-Entragung.

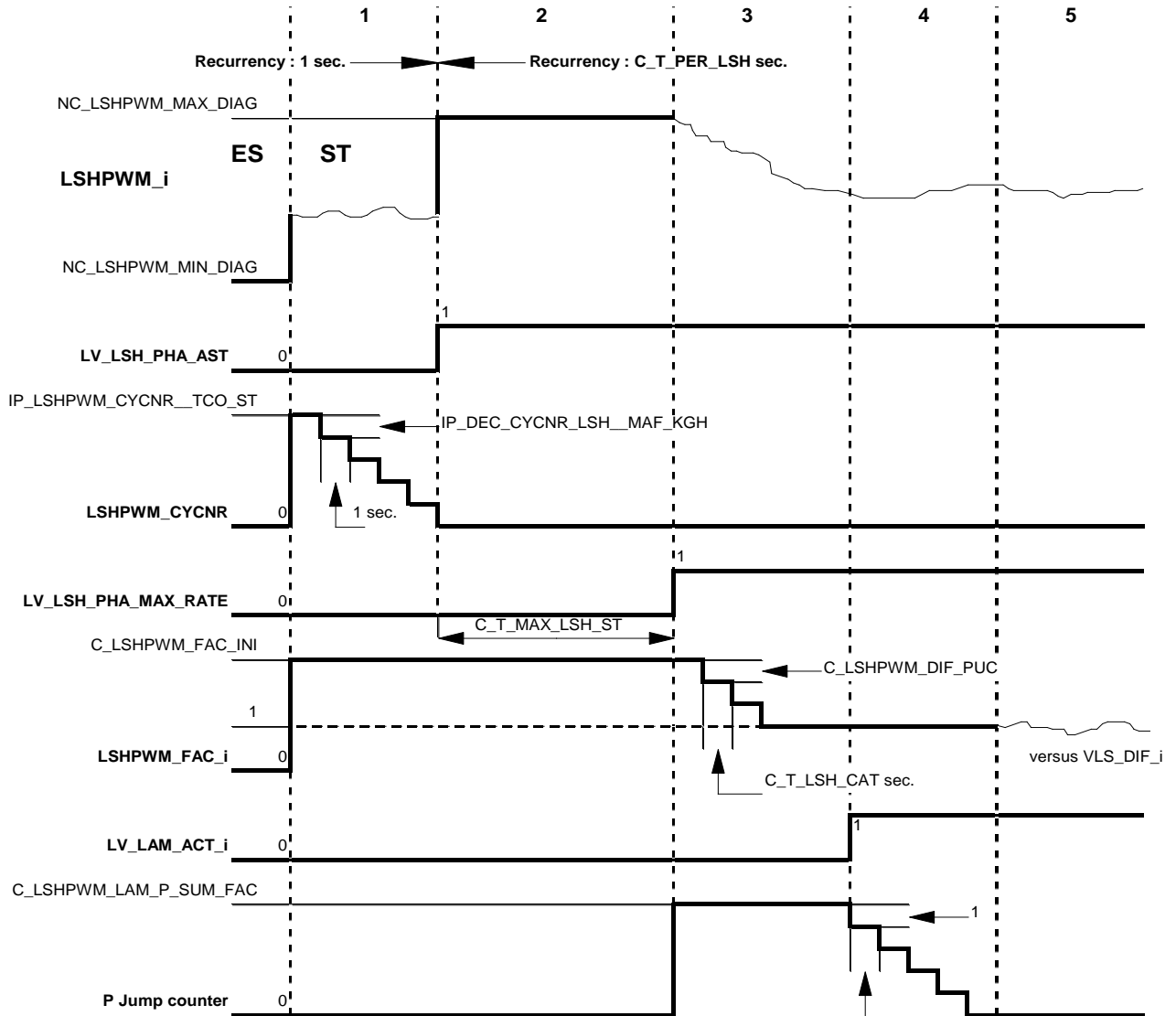

- 1 : $LSHPWM_i = LSHPWM_LGRD_i * C_LSHPWM_T_FAC + C_LSHPWM_i_AS$
- 2 : $LSHPWM_i = NC_LSHPWM_MAX_DIAG$
- 3, 4 : $LSHPWM_i = LSHPWM_LGRD_i * 1 + C_LSHPWM_i_AS$
- 5 : $LSHPWM_i = LSHPWM_LGRD_i * LSHPWM_FAC_i + C_LSHPWM_i_AS$

Editor: Müller O.	17-Dec-97	Injection	HMC_V6
Version: a 153589 from 18.12.97		657765.49.06	
File: CHAP_7.DOC	650H0000	Sourcefile:07701D01.00H	Page 90 / 121

Calibration data:

Name	Dim	Hex. limits	Phys. limits	Resol.	Unit
IP_LSHPWM_CYCNR__TIA_ST	6	0...FFFFH	0...65535	1	-
Cycle counter for preliminary heating phase.					
IP_DEC_CYCNR_LSH__MAF_KGH	6	0...FFFFH	0...65535	1	-
Decrementation of the cycle counter for preliminary heating phase.					
IP_LSHPWM_1__N_32__MAF	6 x 6	0...FFH	0...99.61	100 / 256	%
Basic upstream O2 sensor heating Bank n°1					
IP_LSHPWM_2__N_32__MAF	6 x 6	0...FFH	0...99.61	100 / 256	%
Basic upstream O2 sensor heating Bank n°2					
IP_LSHPWM_VB_FAC__VB	6	0...FFH	0...3.9844	0.0156	-
Battery voltage weighting factor for basic upstream O2 sensors heating					
IP_LSHPWM_LGRD_POS__MAF_KGH	6	01...FFFFH	0.0015...99.998	0.0015	%
Gradient limitation for upstream O2 sensors heating in increasing direction.					
IP_LSHPWM_LGRD_NEG__MAF_KGH	6	01...FFFFH	0.0015...99.998	0.0015	%
Gradient limitation for upstream O2 sensor heating in decreasing direction.					
IP_LSHPWM_DIF_I_1__VLS_DIF_1	8	00...FFH	0...1.922	7.509E-3	-
LSHPWM_FAC_i integral correction for upstream O2 sensor Bank n° 1.					
IP_LSHPWM_DIF_I_2__VLS_DIF_2	8	00...FFH	0...1.922	7.509E-3	-
LSHPWM_FAC_i integral correction for upstream O2 sensor Bank n° 2.					
C_LSHPWM_DIF_PUC	1	00...FFH	0...1.992	7.782E-3	-
LSHPWM_FAC_i gradient limitation in case of un-controlled oxygen sensor heater.					
C_LSHPWM_FAC_MIN	1	0...80H	0...1.9922	2 / 256	-
LSHPWM_FAC_i minimum limit.					
C_LSHPWM_FAC_MAX	1	80...FFH	1...1.9922	2 / 256	-
LSHPWM_FAC_i maximum limit.					
C_VLS_SP	1	0...FFH	0...9.96	10 / 256	V.
VLS_i variation target value for heating regulation.					
C_T_PER_LSH	1	01...32H	0.1...5	0.1	sec
LSHPWM_i calculation recurrence.					
IP_T_MAX_LSH_ST__TCO_ST	6	01...FFH	1...255	1	sec
Time counter for full rating heating (LSHPWM_i = NC_LSHPWM_MAX_DIAG %) following pre-heating phase.					
C_LSHPWM_T_FAC	1	0...80H	0...0.9961	2 / 256	-
Weighting factor for basic control duty cycle during preliminary heating phase.					
C_LSHPWM_1_AS	1	80...7FH	-50...49.609	0.3891	%
Specific heating duty cycle by application system for oxygen sensor n° 1.					
C_LSHPWM_2_AS	1	80...7FH	-50...49.609	0.3891	%
Specific heating duty cycle by application system for oxygen sensor n° 2.					
C_LSHPWM_INI_1	1	00...FFH	0...99.6	0.3891	%
Initialisation-value of LSHPWM_LGRD_1 at transition LV_ES to LV_ST.					
C_LSHPWM_INI_2	1	00...FFH	0...99.6	0.3891	%
Initialisation-value of LSHPWM_LGRD_2 at transition LV_ES to LV_ST.					
C_LSHPWM_LAM_P_SUM_FAC	1	0...FFH	0...255	1	-
Number of P jumps from TI_LAM_i to start oxygen sensor controller.					

Proprietary data, company confidential. All rights reserved.
 Contit a titre de secret d'entreprise. Tous droits réservés.
 Comunicado como segredo empresarial. Reservados todos os direitos.
 Confidado como secreto industrial. Nos reservamos todos los derechos.

Weitergabe sowie Vervielfältigung dieser Unterlage, Verwertung und Mitteilung ihres Inhalts nicht gestattet, soweit nicht ausdrücklich zugestanden. Zuwiderhandlungen verpflichten zu Schadenersatz. Alle Rechte vorbehalten, insbesondere für den Fall der Patenterteilung oder GM-Entragung.

Editor: Müller O.	17-Dec-97	Injection	HMC_V6
Version: a 153589 from 18.12.97		657765.49.06	
File: CHAP_7.DOC	650H0000	Sourcefile:07701D01.00H	Page 91 / 121

Calibration data:

Name	Dim	Hex. limits	Phys. limits	Resol.	Unit
C_LSHPWM_FAC_INI	1	40...C0H	0.5...1.5	2 / 256	-
LSHPWM_FAC_i initialization value.					
NC_LSHPWM_MIN_DIAG	1	0...FFH	0...99.610	100 / 256	%
Minimum O2 sensor heater duty cycle - Non applicative value.					
NC_LSHPWM_MAX_DIAG	1	0...FFH	0...99.610	100 / 256	%
Maximum O2 sensor heater duty cycle - Non applicative value.					
NC_LSHPWM_LGRD_MIN	1	0...FFH	0...99.610	100 / 256	%
Minimum gradient limitation O2 sensor heater duty cycle - Non applicative value.					

Applicative Values :

NC_LSHPWM_MIN_DIAG = **06H** = 2,3438 %
 NC_LSHPWM_MAX_DIAG = **F9H** = 97,2656 %
 NC_LSHPWM_LGRD_MIN = **19H** = 9,7652 %

Proprietary data, company confidential. All rights reserved.
 Contient des informations confidentielles. Tous droits réservés.
 Comunicado como secreto empresarial. Reservados todos los derechos.
 Confidado como secreto industrial. Nos reservamos todos los derechos.

Weitergabe sowie Vervielfältigung dieser Unterlage, Verwertung und Mitteilung ihres Inhalts nicht gestattet, soweit nicht ausdrücklich zugestanden. Zuwiderhandlungen verpflichten zu Schadensersatz. Alle Rechte vorbehalten, insbesondere für den Fall der Patenterteilung oder GM-Entragung.

Editor: Müller O.	17-Dec-97	Injection	HMC_V6
Version: a 153589 from 18.12.97		657765.49.06	
File: CHAP_7.DOC	650H0000	Sourcefile:07701D01.00H	Page 92 / 121

1.3.4 Lambda control (TI_LAM_i)

Output data:

Name	Mode	Hex. limits	Phys. limits	Resol.	Unit
TI_LAM_1	V	0...FFH	-50...49.609	0.3891	%
Lambda control injection time correction for bank 1					
TI_LAM_2	V	0...FFH	-50...49.609	0.3891	%
Lambda control injection time correction for bank 2					
T_LAM_DLY_POS_1	V	8000...7FFFH	-2560...2559.9	0.078	ms
Total LAM-p-jump delay time from lean to rich transition for bank 1					
T_LAM_DLY_POS_2	V	8000...7FFFH	-2560...2559.9	0.078	ms
Total LAM-p-jump delay time from lean to rich transition for bank 2					
T_LAM_DLY_NEG_1	V	8000...7FFFH	-2560...2559.9	0.078	ms
Total LAM-p-jump delay time from rich to lean transition for bank 1					
T_LAM_DLY_NEG_2	V	8000...7FFFH	-2560...2559.9	0.078	ms
Total LAM-p-jump delay time from rich to lean transition for bank 2					

Input data:

N	MAF	LV_IS	LV_PL
LV_LSCL_1	LV_LSCL_2	T_LAM_DLY_1	T_LAM_DLY_2
T_DLY_PUC_1	T_DLY_PUC_2	LV_AFR_1	LV_AFR_2
LV_SLOP_CP			

FUNCTION DESCRIPTION:

General information:

The A/F regulation loop adjusts the air / fuel mixture to richness 1. The lambda controller uses a P / I strategy. It is adjusted to produce a leaner or a richer mixture according to the oxygen sensor information of each cylinder bank.

The P / I values are different in idle (LV_IS) and out of idle.

- Application recurrence : **10 msec.**

After entry in idle (LV_IS) from any other engine operating state, the P / I component of the lambda controller is switched to the P / I value for idle (LV_IS) after an adjustable number C_LAM_SUM_P_IS of P jumps.

Editor: Müller O.	17-Dec-97	Injection	HMC_V6
Version: a 153589 from 18.12.97		657765.49.06	
File: CHAP_7.DOC	650H0000	Sourcefile:07701E01.00H	Page 93 / 121

Description:

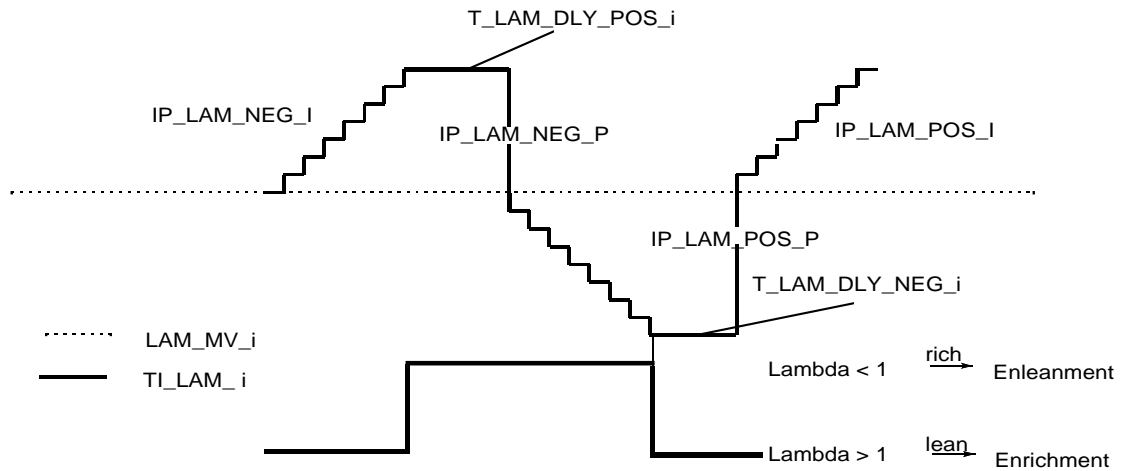

Proprietary data, company confidential. All rights reserved. Contine a titre de secret d'entreprise. Tous droits réservés. Comunicado como segredo empresarial. Reservados todos os direitos. Confidado como secreto industrial. Nos reservamos todos los derechos.

Weitergabe sowie Vervielfältigung dieser Unterlage, Verwertung und Mitteilung ihres Inhalts nicht gestattet, soweit nicht ausdrücklich zugestanden. Zuwiderhandlungen verpflichten zu Schadensersatz. Alle Rechte vorbehalten, insbesondere für den Fall der Patenterteilung oder GM-Enttragung

Application conditions:

Activation:

A/F regulation loop closed (**LV_LSCL_i = 1 (ON)**)

Deactivation:

A/F regulation loop opened (**LV_LSCL_i = 0 (OFF)**)

Formula section:

- *Initialisation :*

From engine stopped (LV_ES) to start (LV_ST) or during system reset, the lambda controller TI_LAM_i is set to **0**.

- *In idle (LV_IS) :*

P component for transition from **lambda > 1 (Lean) ----> lambda < 1 (Rich) :**

$$TI_LAM_i_n = TI_LAM_i_{n-1} - C_LAM_NEG_P_IS * C_LAM_FAC_P$$

P-jump delay time for transition from **lambda > 1 (Lean) ----> lambda < 1 (Rich) :**

```

if          T_LAM_DLY_NEG_i > 0
then       T_LAM_DLY_POS_i = C_T_LAM_DLY_POS_IS
else       T_LAM_DLY_POS_i = C_T_LAM_DLY_POS_IS -
                C_T_LAM_DLY_NEG_IS + T_DLY_PUC_i + T_LAM_DLY_i
    
```

Editor:	Müller O.	17-Dec-97	Injection	HMC_V6
Version:	a 153589 from 18.12.97		657765.49.06	
File:	CHAP_7.DOC	650H0000	Sourcefile:07701E01.00H	Page 94 / 121

Proprietary data, company confidential. All rights reserved.
 Contient des données confidentielles. Tous droits réservés.
 Comunicado como secreto empresarial. Reservados todos los derechos.
 Confidado como secreto industrial. Nos reservamos todos los derechos.

Weitergabe sowie Vervielfältigung dieser Unterlage, Verwertung und Mitteilung ihres Inhalts nicht gestattet, soweit nicht ausdrücklich zugestanden. Zuwiderhandlungen verpflichten zu Schadenersatz. Alle Rechte vorbehalten, insbesondere für den Fall der Patenterteilung oder GM-Entragung.

I component for **lambda < 1 (Rich)** :

$$TI_LAM_i_n = TI_LAM_i_{n-1} - C_LAM_NEG_I_IS * C_LAM_FAC_I_i$$

Exception:

If LV_SLOP_CP = 1 (Canister purge in Ramp-mode)

then $TI_LAM_i_n = TI_LAM_i_{n-1} - IP_LAM_NEG_I_N_MAF * C_LAM_FAC_I_i$

P component for transition from **lambda < 1 (Rich) ----> lambda > 1 (Lean)** :

$$TI_LAM_i_n = TI_LAM_i_{n-1} + C_LAM_POS_P_IS * C_LAM_FAC_P$$

P-jump delay time for transition from **lambda < 1 (Rich) ----> lambda > 1 (Lean)** :

$$T_LAM_DLY_NEG_i = C_T_LAM_DLY_NEG_IS - T_DLY_PUC_i - T_LAM_DLY_i$$

T_LAM_DLY_NEG_i minimum limit is 0.

I component for **lambda > 1 (Lean)** :

$$TI_LAM_i_n = TI_LAM_i_{n-1} + C_LAM_POS_I_IS * C_LAM_FAC_I_i$$

Exception:

If LV_SLOP_CP = 1 (Canister purge in Ramp-mode)

then $TI_LAM_i_n = TI_LAM_i_{n-1} - IP_LAM_POS_I_N_MAF * C_LAM_FAC_I_i$

- *Out of idle* :

P component for transition from **lambda > 1 (Lean) ----> lambda < 1 (Rich)** :

$$TI_LAM_i_n = TI_LAM_i_{n-1} - IP_LAM_NEG_P_N_MAF * C_LAM_FAC_P$$

P-jump delay time for transition from **lambda > 1 (Lean) ----> lambda < 1 (Rich)** :

If T_LAM_DLY_NEG_i > 0

then T_LAM_DLY_POS_i = IP_T_LAM_DLY_POS_N_MAF

else T_LAM_DLY_POS_i = IP_T_LAM_DLY_POS_N_MAF -

$$IP_T_LAM_DLY_NEG_N_MAF + T_DLY_PUC_i + T_LAM_DLY_i$$

I component for **lambda < 1 (Rich)** :

$$TI_LAM_i_n = TI_LAM_i_{n-1} - IP_LAM_NEG_I_N_MAF * C_LAM_FAC_I_i$$

P component for transition from **lambda < 1 (Rich) ----> lambda > 1 (Lean)** :

$$TI_LAM_i_n = TI_LAM_i_{n-1} + IP_LAM_POS_P_N_MAF * C_LAM_FAC_P$$

P-jump delay time for transition from **lambda < 1 (Rich) ----> lambda > 1 (Lean)** :

$$T_LAM_DLY_NEG_i = IP_T_LAM_DLY_NEG_N_MAF - T_DLY_PUC_i - T_LAM_DLY_i$$

T_LAM_DLY_NEG_i minimum limit is 0.

I component for **lambda > 1 (Lean)** :

$$TI_LAM_i_n = TI_LAM_i_{n-1} + IP_LAM_POS_I_N_MAF * C_LAM_FAC_I_i$$

Remark :

The interpolated table IP_LAM_xx_yy_N_MAF have common list of data points.

Editor:	Müller O.	17-Dec-97	Injection	HMC_V6
Version:	a 153589 from 18.12.97		657765.49.06	
File:	CHAP_7.DOC	650H0000	Sourcefile:07701E01.00H	Page 95 / 121

Calibration data:

Name	Dim	Hex. limits	Phys. limits	Resol.	Unit
IP_LAM_POS_P_N_MAF	8 * 8	0...7FH	0...0.49609	1 / 256	-
Basic value of TI_LAM proportional component out of idle during transition lambda < 1 (Rich) --> lambda > 1 (Lean).					
IP_LAM_NEG_P_N_MAF	8 * 8	0...7FH	0...0.49609	1 / 256	-
Basic value of TI_LAM proportional component out of idle during transition lambda > 1 (Lean) --> lambda < 1 (Rich).					
IP_LAM_POS_I_N_MAF	8 * 8	0...7FH	0...0.49609	1 / 256	-
Basic value of TI_LAM integral component out of idle when lambda > 1 (Lean).					
IP_LAM_NEG_I_N_MAF	8 * 8	0...7FH	0...0.49609	1 / 256	-
Basic value of TI_LAM integral component out idle when lambda < 1 (Rich).					
C_LAM_FAC_P	1	00...FFH	0...0.997	3.895E-3	-
Scale factor for TI_LAM proportional component.					
C_LAM_FAC_I_1	1	00...FFH	0...0.997	3.895E-3	-
Scale factor for TI_LAM integral component for bank n° 1					
C_LAM_FAC_I_2	1	00...FFH	0...0.997	3.895E-3	-
Scale factor for TI_LAM integral component for bank n° 2					
C_LAM_POS_P_IS	1	0...7FH	0...0.49609	1 / 256	-
Basic value of TI_LAM proportional component in idle during transition lambda < 1 (Rich) --> lambda > 1 (Lean).					
C_LAM_NEG_P_IS	1	0...7FH	0...0.49609	1 / 256	-
Basic value of TI_LAM proportional component in idle during transition lambda > 1 (Lean) --> lambda < 1 (Rich).					
C_LAM_POS_I_IS	1	0...7FH	0...0.49609	1 / 256	-
Basic value of TI_LAM integral component in idle when lambda > 1 (Lean).					
C_LAM_NEG_I_IS	1	0...7FH	0...0.49609	1 / 256	-
Basic value of TI_LAM integral component in idle when lambda < 1 (Rich).					
C_LAM_SUM_P_IS	1	0...FFH	0...255	1	-
Lambda controller P jump delay to have idle P/I values.					
IP_T_LAM_DLY_POS_N_MAF	8*8	0...3FFFH	0...1279.9	0.078	ms
Basic LAM-p-jump delay for transition from lean to rich					
IP_T_LAM_DLY_NEG_N_MAF	8*8	0...3FFFH	0...1279.9	0.078	ms
Basic LAM-p-jump delay for transition from rich to lean					
C_T_LAM_DLY_POS_IS	1	0...3FFFH	0...1279.9	0.078	ms
Basic LAM-p-jump delay for transition from lean to rich in idle					
C_T_LAM_DLY_NEG_IS	1	0...3FFFH	0...1279.9	0.078	ms
Basic LAM-p-jump delay for transition from rich to lean in idle					

Proprietary data, company confidential. All rights reserved.
 Contine a titre de secret d'entreprise. Tous droits réservés.
 Comunicado como segredo empresarial. Reservados todos los derechos.
 Confidado como secreto industrial. Nos reservamos todos los derechos.

Weitergabe sowie Vervielfältigung dieser Unterlage, Verwertung und Mitteilung ihres Inhalts nicht gestattet, soweit nicht ausdrücklich zugestanden. Zuwiderhandlungen verpflichten zu Schadenersatz. Alle Rechte vorbehalten, insbesondere für den Fall der Patenterteilung oder GM-Entragung.

Editor: Müller O.	17-Dec-97	Injection	HMC_V6
Version: a 153589 from 18.12.97		657765.49.06	
File: CHAP_7.DOC	650H0000	Sourcefile:07701E01.00H	Page 96 / 121

1.3.4.1 Lambda controller limits

Output data:

Name	Mode	Hex. limits	Phys. limits	Resol.	Unit
TI_LAM_MAX_1	-	0...FFH	-50...49.609	0.3891	%
Upper lambda controller limit for bank 1					
TI_LAM_MAX_2	-	0...FFH	-50...49.609	0.3891	%
Upper lambda controller limit for bank 2					
TI_LAM_MIN_1	-	0...FFH	-50...49.609	0.3891	%
Lower lambda controller limit for bank 1					
TI_LAM_MIN_2	-	0...FFH	-50...49.609	0.3891	%
Lower lambda controller limit for bank 2					

Input data:

TI_AD_FAC_MMV_1	TI_AD_FAC_MMV_2	LV_LEARN_CP	CPPWM
-----------------	-----------------	-------------	-------

FUNCTION DESCRIPTION:

General information:

The limits for the lambda controller are C_LAM_MAX and C_LAM_MIN.
If the lambda adaptation value TI_AD_FAC_MMV_i ≠ 0, these limits are changed.

Formula section:

$TI_AD_FAC_MMV_i > 0 :$

- TI_LAM_MIN_i = C_LAM_MIN
- TI_LAM_MAX_i :
 - if** LV_LEARN_CP = 1
(LEARNING mode from evaporative emission control in process (CPPWM ≠ 0))
 - then** TI_LAM_MAX_i = C_LAM_MAX
 - else**
 - if** TI_AD_FAC_MMV_i < C_LAM_MAX
 - then** TI_LAM_MAX_i = C_LAM_MAX - TI_AD_FAC_MMV_i
 - else** TI_LAM_MAX_i = 0

$TI_AD_FAC_MMV_i < 0 :$

- TI_LAM_MAX_i = C_LAM_MAX
- TI_LAM_MIN_i :
 - if** LV_LEARN_CP = 1
(LEARNING mode from evaporative emission control in process (CPPWM ≠ 0))
 - then** TI_LAM_MIN_i = C_LAM_MIN
 - else**
 - if** C_LAM_MIN < TI_AD_FAC_MMV_i
 - then** TI_LAM_MIN_i = C_LAM_MIN - TI_AD_FAC_MMV_i
 - else** TI_LAM_MIN_i = 0

Editor: Müller O.	17-Dec-97	Injection	HMC_V6
Version: a 153589 from 18.12.97		657765.49.06	
File: CHAP_7.DOC	650H0000	Sourcefile:07701E01.00H	Page 97 / 121

Proprietary data, company confidential. All rights reserved.
 Contine a titre de secret d'entreprise. Tous droits réservés.
 Comunicado como segredo empresarial. Reservados todos os direitos.
 Confidado como secreto industrial. Nos reservamos todos los derechos.

Weitergabe sowie Vervielfältigung dieser Unterlage, Verwertung und Mitteilung ihres Inhalts nicht gestattet, soweit nicht ausdrücklich zugestanden. Zuwiderhandlungen verpflichten zu Schadensersatz. Alle Rechte vorbehalten, insbesondere für den Fall der Patenterteilung oder GM-Entragung.

Calibration data:

Name	Dim	Hex. limits	Phys. limits	Resol.	Unit
C_LAM_MIN	1	3000...8000H	-31.25...0	100 / 65536	%
Minimum TI_LAM value.					
C_LAM_MAX	1	8000...D000H	0...31.25	100 / 65536	%
Maximum TI_LAM value.					

Editor: Müller O.	17-Dec-97	Injection	HMC_V6
Version: a 153589 from 18.12.97		657765.49.06	
File: CHAP_7.DOC	650H0000	Sourcefile:07701E01.00H	Page 98 / 121

1.3.4.2 LAM_i and LAM_MV_i calculation

Output data:

Name	Mode	Hex. limits	Phys. limits	Resol.	Unit
LAM_1	-	0...FFH	-50...49.609	100 / 256	%
TI_LAM value after a P jump for bank n° 1					
LAM_2	-	0...FFH	-50...49.609	100 / 256	%
TI_LAM value after a P jump for bank n° 2					
LAM_MV_1	V	0...FFH	-50...49.609	100 / 256	%
TI_LAM average value for bank n° 1					
LAM_MV_2	V	0...FFH	-50...49.609	100 / 256	%
TI_LAM average value for bank n° 2					

Input data:

TI_LAM_1	TI_LAM_2	LV_AFR_1	LV_AFR_2
----------	----------	----------	----------

FUNCTION DESCRIPTION:

General information:

Various functions, e.g. lambda adaptation and control of the evaporative emissions control system, require the lambda controller mean value LAM_MV_i.

LAM_i (used for LAM_MV_ calculation) is the TI_LAM_i value after each P jump of the lambda controller.

- Application recurrence : **P Jump**

Proprietary data, company confidential. All rights reserved. Contient des informations confidentielles. Tous droits réservés. Comunicado como segredo empresarial. Reservados todos os direitos. Confidado como secreto industrial. Nos reservamos todos los derechos.

Weitergabe sowie Vervielfältigung dieser Unterlage, Verwertung und Mitteilung ihres Inhalts ist gestattet, soweit nicht ausdrücklich zugestanden. Zuwiderhandlungen verpflichten zu Schadensersatz. Alle Rechte vorbehalten, insbesondere für den Fall der Patenterteilung oder GM-Entragung.

Editor: Müller O.	17-Dec-97	Injection	HMC_V6
Version: a 153589 from 18.12.97		657765.49.06	
File: CHAP_7.DOC	650H0000	Sourcefile:07701E01.00H	Page 99 / 121

Description:

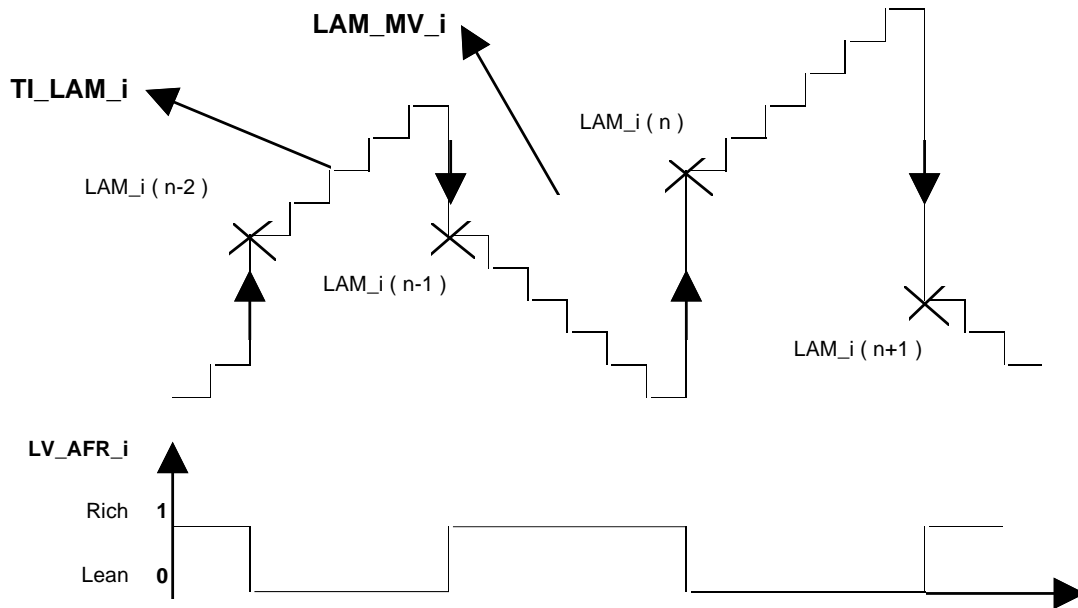

Formula section:

$$LAM_MV_i_n = (LAM_i_{n-1} + LAM_i_n) / 2$$

Proprietary data, company confidential. All rights reserved. Contine a titre de secret d'entreprise. Tous droits réservés. Comunicado como segredo empresarial. Reservados todos os direitos. Confidado como secreto industrial. Nos reservamos todos los derechos.

Weitergabe sowie Vervielfältigung dieser Unterlage, Verwertung und Mitteilung ihres Inhalts nicht gestattet, soweit nicht ausdrücklich zugestanden. Zuwiderhandlungen verpflichten zu Schadensersatz. Alle Rechte vorbehalten, insbesondere für den Fall der Patenterteilung oder GM-Eintragung.

Editor:	Müller O.	17-Dec-97	Injection	HMC_V6
Version:	a 153589 from 18.12.97		657765.49.06	
File:	CHAP_7.DOC	650H0000	Sourcefile:07701E01.00H	Page 100 / 121

1.3.4.3 Conditions for limited dynamics

Output data:

Name	Mode	Hex. limits	Phys. limits	Resol.	Unit
MAF_MV_1	V	0...FFH	0...1389	5.45	mg/TDC
MAF average value for bank n° 1					
MAF_MV_2	V	0...FFH	0...1389	5.45	mg/TDC
MAF average value for bank n° 2					
N_MV_1	V	0...FFH	0..8160	32	rpm
N average value for bank n° 1					
N_MV_2	V	0...FFH	0..8160	32	rpm
N average value for bank n° 2					
LAM_MV_DYW_1	V	00...FFH	-50...49.609	0.3891	%
LAM_MV average value for bank n° 1					
LAM_MV_DYW_2	V	00...FFH	-50...49.609	0.3891	%
LAM_MV average value for bank n° 2					
LV_N_MAF_DYW_1	V	0...01H	0..1	1	-
Boolean for limited dynamics N, MAF for bank n° 1 - (Passive / Active).					
LV_N_MAF_DYW_2	V	0...01H	0..1	1	-
Boolean for limited dynamics N, MAF for bank n° 2 - (Passive / Active).					
LV_LAM_DYW_1	V	0...01H	0..1	1	-
Boolean for limited dynamics LAM for bank n° 1 - (Passive / Active).					
LV_LAM_DYW_2	V	0...01H	0..1	1	-
Boolean for limited dynamics LAM for bank n° 2 - (Passive / Active).					

Input data:

MAF	N	LAM_MV_1	LAM_MV_2
LV_LEARN_CP			

FUNCTION DESCRIPTION:

General information:

Limited dynamics conditions for a variable exist if the current value stays around its mean value within a tolerance window. This check is made each P jump of the lambda controller.

Variables checked :

MAF
N
LAM_MV_i

Mean variables :

MAF_MV_i
N_MV_i
LAM_MV_DYW_i

Editor: Müller O.	17-Dec-97	Injection	HMC_V6
Version: a 153589 from 18.12.97		657765.49.06	
File: CHAP_7.DOC	650H0000	Sourcefile:07701E01.00H	Page 101 / 121

Proprietary data, company confidential. All rights reserved.
 Contit a titre de secret d'entreprise. Tous droits réservés.
 Comunicado como secreto empresarial. Reservados todos os direitos.
 Confidado como secreto industrial. Nos reservamos todos los derechos.

Weitergabe sowie Vervielfältigung dieser Unterlage, Verwertung und Mitteilung ihres Inhalts nicht gestattet, soweit nicht ausdrücklich zugestanden. Zuwiderhandlungen verpflichten zu Schadenersatz. Alle Rechte vorbehalten, insbesondere für den Fall der Patenterteilung oder GM-Entragung

Formula section:

- Limited dynamics conditions for engine operating point (N, MAF) :

```

if          | MAF - MAF_MV_i | < C_MAF_DYW
      and     | N - N_MV_i | < C_N_DYW
      then    LV_N_MAF_DYW_i = 1 (Active)
      else    LV_N_MAF_DYW_i = 0 (Passive)
      and     MAF_MV_i = MAF
      and     N_MV_i = N
      and     LAM_MV_DYW_i = LAM_MV_i
Endif.
    
```

- Limited dynamics conditions for lambda controller (LAM_MV_i) :

```

if          | LAM_MV_i - LAM_MV_DYW_i | < C_LAM_MV_DYW
      and     LV_LEARN_CP = 0
              (LEARNING mode from evaporative emission control over)
      then    LV_LAM_DYW_i = 1 (Active)
      else    LV_LAM_DYW_i = 0 (Passive)
      and     LAM_MV_DYW_i = LAM_MV_i
      and     MAF_MV_i = MAF
      and     N_MV_i = N
Endif.
    
```

Calibration data:

Name	Dim	Hex. limits	Phys. limits	Resol.	Unit
C_MAF_DYW	1	0...FFH	0...1389	5.45	mg/TDC
MAF window for limited dynamics.					
C_N_DYW	1	0...1FE0H	0...8160	1	rpm
N window for limited dynamics.					
C_LAM_MV_DYW	1	00...FFH	0...99.609	0.3891	%
LAM_MV window for limited dynamics.					

Editor: Müller O.	17-Dec-97	Injection	HMC_V6
Version: a 153589 from 18.12.97		657765.49.06	
File: CHAP_7.DOC	650H0000	Sourcefile:07701E01.00H	Page 102 / 121

1.3.5 Lambda adaptation (TI_AD_ADD_MMV_COR_i, TI_AD_FAC_MMV_COR_i)

Output data:

Name	Mode	Hex. limits	Phys. limits	Resol.	Unit
TI_AD_ADD_MMV_i	V/S	8000...7FFFH	-131.07...131.06	4 µsec	msec
Additive adaptative factor for bank n° i					
TI_AD_FAC_MMV_i	V/S	00...FFFFH	-50...49.998	1.526E-3	%
Multiplicative adaptative factor for bank n° i					
TI_AD_ADD_MMV_REL_i	V	8000...7FFFH	-50...49.998	1.526E-3	msec
Relative additive adaptative factor for bank n° i					
TI_AD_ADD_MMV_COR_i	V	8000...7FFFH	-131.07...131.06	4 µsec	msec
Additive adaptative factor for bank n° i weighted by coolant temperature during warm-up.					
TI_AD_FAC_MMV_COR_i	V	00...FFFFH	-50...49.998	1.526E-3	%
Multiplicative adaptative factor for bank n° i weighted by coolant temperature during warm-up					
LV_TI_AD_ACT_i	V	0...01H	0...1	1	-
Boolean for TI adaptation activation for bank n° i (Passive / Active).					
TI_AD_ACT_i	V	0...04H	0...4	1	-
Information for TI adaptation calculation type for bank n° i - (0 : Passive, 1 : ADD_ACT, 3 : FAC_ACT)					

Input data:

TCO	TIA	N	MAF
TI_LAM_i	TIB	CPPWM	MAF_KGH
LAM_MV_i	LAM_MV_DYW_i	LV_LSCL_i	C_FAC_MIN_P_CP
LV_PL	LV_IS	LV_AUTH_LAM_AD_CP	LV_STB_PHA_CP
LV_LAM_DYW_i	LV_N_MAF_DYW_i	LV_AUTH_LAM_i_AD_LEA RN_CP	LV_LAM_LIM_i_ERR
LV_TPS_ERR	LV_TPS_PLAUS_ERR	LV_MAF_ERR	LV_MAF_PLAUS_ERR
LV_ISA_i_ERR	LV_ISA_MECHA_ERR	LV_CAM_ERR	LV_TIA_ERR
LV_SAV_ERR	LV_SAV_MECHA_ERR	LV_TCO_ERR	LV_TCO_PLAUS_ERR
LV_CPS_ERR	LV_CPS_MECHA_ERR	LV_VLS_LIM_ERR	LV_FSD_ERR

FUNCTION DESCRIPTION:

General information:

In order to compensate serial production tolerances of components, adaptative corrections (additive and multiplicative) are calculated, versus the TI_LAM_i values.

They must be centered to 0 dec. **(80H)**.

- Application recurrence : **20 msec**.

Editor: Müller O.	17-Dec-97	Injection	HMC_V6
Version: a 153589 from 18.12.97		657765.49.06	
File: CHAP_7.DOC	650H0000	Sourcefile:07701F01.00J	Page 103 / 121

1.3.5.1 Application conditions (LV_TI_AD_ACT_i)

If TCO > C_TI_TCO_AD_MIN
and TIA < C_TI_TIA_AD_MAX
and MAF_KGH < C_TI_MAF_AD_MAX
and LV_LSCL_i = 1 (A/F regulation loop closed)
and LV_LAM_LIM_i_ERR = 0 (no error currently present on Lambda controller)
and LV_TPS_ERR = 0
(no error currently present on throttle position sensor)
and LV_TPS_PLAUS_ERR = 0
(no plausibility error currently present on throttle position sensor)
and LV_MAF_ERR = 0
(no error currently present on mass air flow sensor)
and LV_MAF_PLAUS_ERR = 0
(no plausibility error currently present on mass air flow sensor)
and LV_ISA_i_ERR = 0
(no error currently present on idle charge actuator command signal)
and LV_ISA_MECHA_ERR = 0
(no mechanical error currently present on idle speed actuator)
and LV_CAM_ERR = 0
(no error currently present on camshaft sensor)
and LV_TIA_ERR = 0
(no error currently present on air temperature sensor)
and LV_TCO_ERR = 0
(no error currently present on coolant temperature sensor)
and LV_TCO_PLAUS_ERR = 0
(no plausibility error currently present on coolant temperature sensor)
and LV_VLS_LIM_ERR = 0
(no error currently present on O2-sensor voltage excursion)
and LV_FSD_ERR = 0
(no error currently present on fuel system)
and LV_CPS_ERR = 0
(no error currently present on canister purge solenoid)
and LV_CPS_MECHA_ERR = 0
(no mechanical error currently present on canister purge solenoid)
and LV_SAV_ERR = 0
(no error currently present on secondary air valve power stage)
and LV_SAV_MECHA_ERR = 0 (Passive)
(diagnosis inactive for mechanical error detection on secondary air valve)
and LV_LAM_DYW_i = 1 (Active)
(steady state defined by limited dynamics conditions for lambda controller)
and LV_AUTH_LAM_AD_CP = 1 (Active)
(lambda adaptation authorized by evaporative emissions control process)
or LV_AUTH_LAM_i_AD_LEARN_CP = 1 (Active)
(lambda adaptation authorized by evaporative emissions control process)
and LV_AUTH_LAM_i_AD_LEARN_CP = 1 (Active)
(lambda adaptation authorized by evaporative emissions control process)
or LV_N_MAF_DYW_i = 1 (Active)
(steady state defined by limited dynamics cond. for engine op. point)
then LV_TI_AD_ACT_i = 1 (Active)
else LV_TI_AD_ACT_i = 0 (Passive)

Editor:	Müller O.	17-Dec-97	Injection	HMC_V6
Version:	a 153589 from 18.12.97		657765.49.06	
File:	CHAP_7.DOC	650H0000	Sourcefile:07701F01.00J	Page 104 / 121

1.3.5.2 Learning area (TI_AD_ACT_i)

Proprietary data, company confidential. All rights reserved.
 Contient des données confidentielles de la société. Tous droits réservés.
 Comunicado como secreto empresarial. Reservados todos los derechos.
 Confidado como secreto industrial. Nos reservamos todos los derechos.

```

if LV_TI_AD_ACT_i = 1 (Active)
    (application conditions for lambda adaptation are fulfilled)
then
    if N < C_TI_N_AD_ADD_MAX(_AT)
    and MAF < C_TI_MAF_AD_ADD_MAX(_AT)
    then TI_AD_ACT_i = 1 (= ADD_ACT)
    (additive adaptation correction calculation for injection time
    authorized)
    else
    if N > C_TI_N_AD_FAC_MIN(_AT)
    and MAF > C_TI_MAF_AD_FAC_MIN(_AT)
    then TI_AD_ACT_i = 3 (= FAC_ACT)
    (multiplicative adaptation correction calculation for injection
    time authorized)
    else TI_AD_ACT_i = 0 (Passive)
    
```

Description:

Weitergabe sowie Vervielfältigung dieser Unterlage, Verwertung und Mitteilung ihres Inhalts ist gestattet, soweit nicht ausdrücklich zugestanden. Zuwiderhandlungen verpflichten zu Schadensersatz. Alle Rechte vorbehalten, insbesondere für den Fall der Patenterteilung oder GM-Entragung

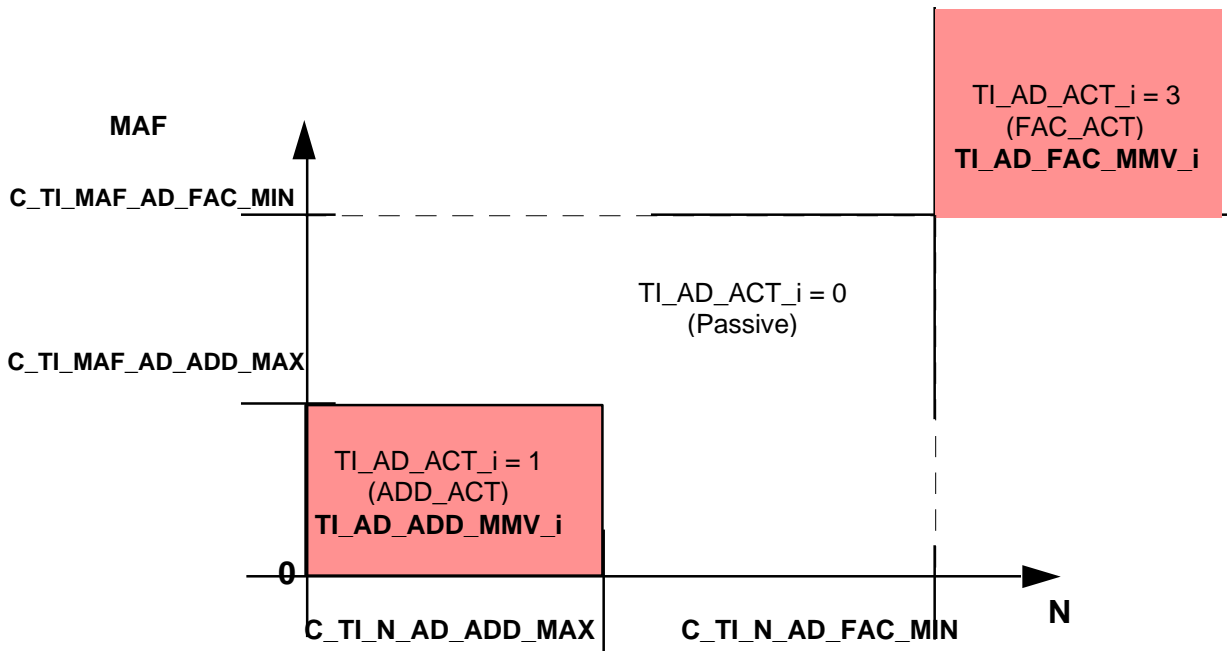

Editor: Müller O.	17-Dec-97	Injection	HMC_V6
Version: a 153589 from 18.12.97		657765.49.06	
File: CHAP_7.DOC	650H0000	Sourcefile:07701F01.00J	Page 105 / 121

Proprietary data, company confidential. All rights reserved. Contine a titre de secret d'entreprise. Tous droits réservés. Comunicado como segredo empresarial. Reservados todos os direitos. Confidado como secreto industrial. Nos reservamos todos los derechos.

Weitergabe sowie Vervielfältigung dieser Unterlage, Verwertung und Mitteilung ihres Inhalts nicht gestattet, soweit nicht ausdrücklich zugestanden. Zuwiderhandlungen verpflichten zu Schadenersatz. Alle Rechte vorbehalten, insbesondere für den Fall der Patenterteilung oder GM-Enttragung.

1.3.5.3 Lambda adaptation calculation period

Once the activation conditions are active ($LV_TI_AD_ACT_i = 1$ (Active)), the adaptation calculation takes place when a number of P - Jumps are performed by the lambda controller:

- in idle ($LV_IS = 1$) : $C_LAM_AD_SUM_P_IS$
- out of idle : $C_LAM_AD_SUM_P$

Another adaptation calculation occurs when the number of P - Jumps is reached. When the activation conditions are exited ($LV_TI_AD_ACT_i = 0$ (Passive)), the current number of P - Jumps is reset.

Remark :

If $LV_AUTH_LAM_i_AD_LEARN_CP = 1$ (Active) (lambda adaptation authorized by evaporative emissions control process during LEARNING mode with $CPPWM = 0$) and the number of P - Jumps from lambda controller is more than $C_FAC_MIN_P_CP$, then the adaptation calculation is performed.

1.3.5.4 Correlation factor for lambda adaptation calculation

- **Canister purge in Stand-by-mode:** Lambda adaptation possible, correlation factor is:
 $C_TI_AD_COR_CRLC_XX = C_TI_AD_COR_CRLC_IS$ if $LV_IS = 1$
 $C_TI_AD_COR_CRLC_XX = C_TI_AD_COR_CRLC$ if $LV_IS = 0$
- **Canister purge in Min-mode:** Lambda adaptation possible if $CPPWM = 0$, correlation factor is:
 $C_TI_AD_COR_CRLC_XX = C_TI_AD_COR_CRLC_IS$ if $LV_IS = 1$
 $C_TI_AD_COR_CRLC_XX = C_TI_AD_COR_CRLC$ if $LV_IS = 0$
- **Canister purge in Normal-mode:** Lambda adaptation possible, correlation factor is:
 $C_TI_AD_COR_CRLC_XX = C_TI_AD_COR_CRLC_CP$
- **Canister purge in Ramp-mode:** Lambda adaptation is not possible, Exception: with LAM_MV_BEG determination at $FAC_CP = 0$; weighting factor is
 $C_TI_AD_COR_CRLC_XX = C_TI_AD_COR_CRLC_LD$

Editor: Müller O.	17-Dec-97	Injection	HMC_V6
Version: a 153589 from 18.12.97		657765.49.06	
File: CHAP_7.DOC	650H0000	Sourcefile:07701F01.00J	Page 106 / 121

1.3.5.5 Lambda adaptation calculation (TI_AD_ADD_MMV_i, TI_AD_FAC_MMV_i)

Proprietary data, company confidential. All rights reserved. Contient a titre de secret d'entreprise. Tous droits réservés. Comunicado como segredo empresarial. Reservados todos os direitos. Confidado como secreto industrial. Nos reservamos todos los derechos.

Weitergabe sowie Veröffentlichung dieser Unterlage, Verwertung und Mitteilung ihres Inhalts nicht gestattet, soweit nicht ausdrücklich zugestanden. Zuwiderhandlungen verpflichten zu Schadensersatz. Alle Rechte vorbehalten, insbesondere für den Fall der Patenterteilung oder GM-Entragung.

If LV_TI_AD_ACT_i = 1
(application conditions for lambda adaptation are fulfilled)
and TI_AD_ACT_i = 1 (ADD_ACT)
(additive adaptation correction calculation for injection time authorized)

then

$$\begin{aligned}
 TI_AD_ADD_MMV_i_n = & TI_AD_ADD_MMV_i_{n-1} \\
 & + [C_TI_AD_COR_CRLC_xx * LAM_MV_DYW_i * TIB \\
 & * N / C_TI_N_AD_ADD_MAX(AT)]
 \end{aligned}$$

and

$$TI_AD_ADD_MMV_REL_i_n = [TI_AD_ADD_MMV_i_n * C_TI_N_AD_ADD_MAX(AT) / N] / TIB$$

and

$$\begin{aligned}
 K &= [TI_AD_ADD_MMV_REL_i_n - TI_AD_ADD_MMV_REL_i_{n-1}] \\
 TI_LAM_i_n &= TI_LAM_i_{n-1} - K \\
 LAM_MV_i_n &= LAM_MV_i_{n-1} - K \\
 LAM_MV_DYW_i_n &= LAM_MV_DYW_i_{n-1} - K
 \end{aligned}$$

else

If LV_TI_AD_ACT_i = 1
(application conditions for lambda adaptation are fulfilled)
and TI_AD_ACT_i = 3 (FAC_ACT)
(multiplicative adaptation correction calculation for injection time authorized)

then

$$\begin{aligned}
 TI_AD_FAC_MMV_i_n = & TI_AD_FAC_MMV_i_{n-1} \\
 & + [C_TI_AD_COR_CRLC_xx * LAM_MV_DYW_i]
 \end{aligned}$$

and

$$\begin{aligned}
 K &= [TI_AD_FAC_MMV_i_n - TI_AD_FAC_MMV_i_{n-1}] \\
 TI_LAM_i_n &= TI_LAM_i_{n-1} - K \\
 LAM_MV_i_n &= LAM_MV_i_{n-1} - K \\
 LAM_MV_DYW_i_n &= LAM_MV_DYW_i_{n-1} - K
 \end{aligned}$$

Editor: Müller O.	17-Dec-97	Injection	HMC_V6
Version: a 153589 from 18.12.97		657765.49.06	
File: CHAP_7.DOC	650H0000	Sourcefile:07701F01.00J	Page 107 / 121

1.3.5.6 Lambda adaptation correction during warm-up

General information:

In order to avoid mixture problems when the engine has not reached its service temperature, the lambda adaptation values (additive and multiplicative) can be decreased versus TCO and their own value (applied when engine runs with its service temperature).

It is performed by weighting the adaptative factors as long as the lambda adaptation is disabled due to the coolant temperature threshold C_TI_TCO_AD_MIN.

Formula section:

If $TCO < C_TI_TCO_AD_MIN$
then

$TI_AD_ADD_MMV_i_n = TI_AD_ADD_MMV_i_{n-1} * IP_TI_AD_ADD_FAC_TCO_TI_AD_ADD_MMV$ <p style="text-align: center;">and</p> $TI_AD_FAC_MMV_i_n = TI_AD_FAC_MMV_i_{n-1} * IP_TI_AD_FAC_FAC_TCO_TI_AD_FAC_MMV$
--

Endif.

If $TCO \geq C_TI_TCO_AD_MIN$
then

$TI_AD_ADD_MMV_COR_i_n = TI_AD_ADD_MMV_i_n * C_TI_N_AD_ADD_MAX_AT / N$ <p style="text-align: center;">and</p> $TI_AD_FAC_MMV_COR_i_n = TI_AD_FAC_MMV_i_n$

else

$TI_AD_ADD_MMV_COR_i_n = TI_AD_ADD_MMV_i_n * C_TI_N_AD_ADD_MAX_AT / N * IP_TI_AD_ADD_FAC_TCO_TI_AD_ADD_MMV$ <p style="text-align: center;">and</p> $TI_AD_FAC_MMV_COR_i_n = TI_AD_FAC_MMV_i_n * IP_TI_AD_FAC_FAC_TCO_TI_AD_FAC_MMV$

Endif.

Proprietary data, company confidential. All rights reserved.
 Contit a titre de secret d'entreprise. Tous droits réservés.
 Comunicado como segredo empresarial. Reservados todos os direitos.
 Confidado como secreto industrial. Nos reservamos todos los derechos.

Weitergabe sowie Vervielfältigung dieser Unterlage, Verwertung und Mitteilung ihres Inhalts nicht gestattet, soweit nicht ausdrücklich zugestanden. Zuwiderhandlungen verpflichten zu Schadensersatz. Alle Rechte vorbehalten, insbesondere für den Fall der Patenterteilung oder GM-Entragung.

Editor: Müller O.	17-Dec-97	Injection	HMC_V6
Version: a 153589 from 18.12.97		657765.49.06	
File: CHAP_7.DOC	650H0000	Sourcefile:07701F01.00J	Page 108 / 121

1.3.5.7 Lambda adaptation limitation

General information:

In order to avoid big injection time deviation and to detect system failure, the lambda adaptation values are limited. The limitation takes place following calculation of the lambda adaptation values.

$$C_TI_AD_ADD_MIN \leq TI_AD_ADD_MMV_COR_i \leq C_TI_AD_ADD_MAX$$

$$C_TI_AD_FAC_MIN \leq TI_AD_FAC_MMV_COR_i \leq C_TI_AD_FAC_MAX$$

Proprietary data, company confidential. All rights reserved.
 Contient des informations confidentielles. Tous droits réservés.
 Comunicado como secreto empresarial. Reservados todos los derechos.
 Confiado como secreto industrial. Nos reservamos todos los derechos.

Weitergabe sowie Vervielfältigung dieser Unterlage, Verwertung und Mitteilung ihres Inhalts ist gestattet, soweit nicht ausdrücklich zugestanden. Zuwiderhandlungen verpflichten zu Schadensersatz. Alle Rechte vorbehalten, insbesondere für den Fall der Patenterteilung oder GM-Eintragung.

Editor:	Müller O.	17-Dec-97	Injection	HMC_V6
Version:	a 153589 from 18.12.97		657765.49.06	
File:	CHAP_7.DOC	650H0000	Sourcefile:07701F01.00J	Page 109 / 121

Calibration data:

Name	Dim	Hex. limits	Phys. limits	Resol.	Unit
C_TI_TCO_AD_MIN	1	0...FEH	-48...142.5	0.75	°C
Minimum coolant temperature for adaptative learning.					
C_TI_TIA_AD_MAX	1	0...FEH	-48...142.5	0.75	°C
Maximum air temperature for adaptive learning					
C_TI_MAF_AD_MAX	1	0...FFFFH	0...16383.75	0.25	kg/h
Maximum MAF for adaptative learning.					
C_TI_N_AD_ADD_MAX(_AT)	1	01...1FE0H	1...8160	1	rpm
Maximum engine speed for additive adaptative learning.					
C_TI_MAF_AD_ADD_MAX(_AT)	1	0...FFH	0...1389	5.447	mg/TDC
Maximum MAF for additive adaptative learning.					
C_TI_N_AD_FAC_MIN(_AT)	1	01...1FE0H	1...8160	1	rpm
Minimum engine speed for multiplicative adaptative learning.					
C_TI_MAF_AD_FAC_MIN(_AT)	1	0...FFH	0...1389	5.447	mg/TDC
Minimum MAF for multiplicative adaptative learning.					
C_LAM_AD_SUM_P_IS	1	01...FFH	1...255	1	-
P component jump delay between two adaptative learning in idle.					
C_LAM_AD_SUM_P	1	0...FFH	0...255	1	-
P component jump delay between two adaptative learning out of idle.					
C_TI_AD_COR_CRLC	1	00...FFH	0...0.997	3.895E-3	-
Correlation factor for adaptative learning out of idle with LV_AUTH_LAM_AD_CP = 1 or LV_AUTH_LAM_i_AD_LEARN_CP = 0.					
C_TI_AD_COR_CRLC_IS	1	00...FFH	0...0.997	3.895E-3	-
Correlation factor for adaptative learning in idle with LV_AUTH_LAM_AD_CP = 1 or LV_AUTH_LAM_i_AD_LEARN_CP = 0.					
C_TI_AD_COR_CRLC_CP	1	00...FFH	0...0.997	3.895E-3	-
Correlation factor for adaptative learning in NORMAL operation of evaporative emissions control.					
C_TI_AD_COR_CRLC_LD	1	00...FFH	0...0.997	3.895E-3	-
Correlation factor for adaptative learning with LV_AUTH_LAM_i_AD_LEARN_CP = 0.					
IP_TI_AD_ADD_FAC__TCO__TI_AD_ADD_MMV	5 x 5	00...FFH	0...0.997	3.895E-3	-
Multiplicative factor on additive adaptative learning during warm-up.					
IP_TI_AD_FAC_FAC__TCO__TI_AD_FAC_MMV	5 x 5	00...FFH	0...0.997	3.895E-3	-
Multiplicative factor on multiplicative adaptative learning during warm-up.					
C_TI_AD_FAC_MIN	1	3000...8000H	-31.25...0	100 / 65536	%
Minimum value of lambda adaptation multiplicative factor.					
C_TI_AD_FAC_MAX	1	8000...D000H	0...31.25	100 / 65536	%
Maximum value of lambda adaptation multiplicative factor.					
C_TI_AD_ADD_MIN	1	7B1E...8000H	-5...0	4 µsec	msec
Minimum value of lambda adaptation additive factor.					
C_TI_AD_ADD_MAX	1	8000...84E2H	0...+5	4 µsec	msec
Maximum value of lambda adaptation additive factor.					

Proprietary data, company confidential. All rights reserved. Contine a titre de secret d'entreprise. Tous droits réservés. Comunicado como segredo empresarial. Reservados todos os direitos. Confidado como secreto industrial. Nos reservamos todos los derechos.

Weitergabe sowie Vervielfältigung dieser Unterlage, Verwertung und Mitteilung ihres Inhalts nicht gestattet, soweit nicht ausdrücklich zugestanden. Zuwiderhandlungen verpflichten zu Schadenersatz. Alle Rechte vorbehalten, insbesondere für den Fall der Patenterteilung oder GM-Entragung.

Editor:	Müller O.	17-Dec-97	Injection	HMC_V6
Version:	a 153589 from 18.12.97		657765.49.06	
File:	CHAP_7.DOC	650H0000	Sourcefile:07701F01.00J	Page 110 / 121

1.3.6 Downstream fuel trim regulation by LAM - P - Jump delay time

Output data:

Name	Mode	Hex. limits	Phys. limits	Resol.	Unit
VLS_DIF_DLY_i	V	80...7FH	-2,5...2,48	0,0196	V
difference between setpoint and actual downstream LS signal					
T_DLY_P_i	V	0000...FFFFH	0...1279,98	0,0195	ms
LAM-P-jump delay time from P-share					
T_DLY_I_i	V	0000...FFFFH	0...1279,98	0,0195	ms
LAM-P-jump delay time from I-share					
T_DLY_AD_i	V/S	0000...FFFFH	0...1279,98	0,0195	ms
LAM-P-jump delay time from AD-share					
T_LAM_DLY_i	V	0000...FFFFH	0...1279,98	0,0195	ms
LAM-P-jump delay time from downstream trim controller					
FAC_CAT_DLY_i	V	0...FFH	0...0,996	3,9e-3	-
weight factor for P-share regarding catalyst conversion capability					
MAF_INT_DLY_i	V	0...FFFFH	0...11650,66	0,178	g
integral of air mass flow since LAM activation					
LV_LAM_DLY_i	V	0...01H	0...1	1	-
Status for downstream fuel trim regulation activation					
LV_T_DLY_AD_i	V	0...01H	0...1	1	-
Status for downstream fuel trim adaptative term calculation					

Input data:

VLS_CAT_i	CAT_DIAG_TRIM_i	N_32	MAF
TEMP_MMV_SUB_CAT	TI_LAM_i	TI_AD_FAC_MMV_i	TI_AD_ADD_MMV_REL_i
TI_LAM_MIN_i	TI_LAM_MAX_i	LV_LDC_CAT_i	LV_LSCL_i
MAF_KGH	LV_VLS_DOWN_i_ERR	LV_ACT_INT_PUC_i	LV_LSH_DOWN_HP_i_ERR
LV_MAF_ERR	LV_MAF_PLAUS_ERR	LV_TPS_ERR	LV_TPS_PLAUS_ERR
LV_CRK_ERR	LV_CAM_ERR	LV_SAV_ERR	LV_SAV_MECHA_ERR
LV_SAS_ERR	LV_TCO_ERR	LV_CPS_ERR	LV_CPS_MECHA_ERR
LV_LSH_UP_i_ERR	LV_LSH_DOWN_i_ERR	LV_VLS_UP_i_ERR	LV_FSD_i_ERR
LV_VLS_FREQ_i_ERR	LV_VLS_SLOP_i_ERR	LV_VLS_LIM_i_ERR	LV_VLS_DOWN_LIM_i_ERR
LV_LAM_STOP	LV_MIS_[CYL]_ERR		

FUNCTION DESCRIPTION:

General information:

Downstream fuel trim regulation target is to keep a constant dynamic lambda during all the life of the vehicle.

According to downstream O2 sensor voltage, a P-jump time delay is applied on the lambda regulation. This time delay contains three parts:

- integral part: T_DLY_I_i
- proportional part: T_DLY_P_i
- adaptative part: T_DLY_AD_i

Editor: Müller O.	17-Dec-97	Injection	HMC_V6
Version: a 153589 from 18.12.97		657765.49.06	
File: CHAP_7.DOC	650H0000	Sourcefile:07702B01.00D	Page 111 / 121

The downstream O2 sensor voltage represents the target dynamic lambda. Any deviation from this target, is entered in the P-I-AD regulation.

If two separate catalyst systems are concerned then :

i = 1, for cylinder bank 1

i = 2, for cylinder bank 2

Application recurrency: 20ms

Application conditions:

Activation: (LV_LAM_DLY_i = 1)

- 1) No relevant diagnosis entry:
 - LV_MAF_ERR = 0 **and** LV_MAF_PLAUS_ERR = 0
 - and** LV_TPS_ERR = 0 **and** LV_TPS_PLAUS_ERR = 0
 - and** LV_CRK_ERR = 0 **and** LV_CAM_ERR = 0
 - and** LV_SAV_ERR = 0 **and** LV_SAV_MECHA_ERR = 0
 - and** LV_SAS_ERR = 0 **and** LV_TCO_ERR = 0
 - and** LV_CPS_ERR = 0 **and** LV_CPS_MECHA_ERR = 0
 - and** LV_LSH_UP_i_ERR = 0 **and** LV_LSH_DOWN_i_ERR = 0
 - and** LV_LSH_DOWN_HP_i_ERR = 0
 - and** LV_VLS_UP_i_ERR = 0 **and** LV_VLS_DOWN_i_ERR = 0
 - and** LV_VLS_LIM_i_ERR = 0 **and** LV_VLS_DOWN_LIM_i_ERR = 0
 - and** LV_VLS_FREQ_i_ERR = 0 **and** LV_VLS_SLOP_i_ERR = 0
 - and** LV_LAM_STOP = 0 **and** LV_MIS_[CYL]_ERR = 0
 - and** LV_FSD_i_ERR = 0

- 2) TEMP_MMV_SUB_CAT > C_LAM_TEMP_MIN_CAT_DLY
(Catalyst is working) (Hysteresis C_LAM_TEMP_HYS_CAT_DLY is applied when the function is started)

- 3) **and** TI_LAM_MIN_i < TI_LAM_i + TI_AD_FAC_MMV_i + TI_AD_ADD_MMV_REL_i < TI_LAM_MAX_i
(LAM-current value is not limited)

- 4) **and** CAT_DIAG_TRIM_i < C_CAT_DIAG_MAX_DLY
(this condition is considered only if CAT_DIAG_TRIM_i < 256)
and CAT_DIAG_i < C_CAT_DIAG_MAX_DLY
(Catalyst efficiency is in the valid area)

- 5) **and** LV_LDC_CAT_i = 1 *(Limited dynamic is fulfilled)*

- 6) **and** LV_LSCL_i = 1 *(Lambda regulation active)*

- 7) **and** After each activation of the Lambda regulation :
 MAF_INT_DLY_i > C_MAF_INT_MIN_DLY **if** LV_ACT_INT_PUC_i = 0
 MAF_INT_DLY_i > C_MAF_INT_MIN_DLY_PUC **if** LV_ACT_INT_PUC_i = 1

Proprietary data, company confidential. All rights reserved. Contine a titre de secret d'entreprise. Tous droits réservés. Comunicado como secreto empresarial. Reservados todos os direitos. Confidado como secreto industrial. Nos reservamos todos los derechos.

Weitergabe sowie Vervielfältigung dieser Unterlage, Verwertung und Mitteilung ihres Inhalts nicht gestattet, soweit nicht ausdrücklich zugestanden. Zuwiderhandlungen verpflichten zu Schadensersatz. Alle Rechte vorbehalten, insbesondere für den Fall der Patenterteilung oder GM-Enttragung.

Editor: Müller O.	17-Dec-97	Injection	HMC_V6
Version: a 153589 from 18.12.97		657765.49.06	
File: CHAP_7.DOC	650H0000	Sourcefile:07702B01.00D	Page 112 / 121

MAF_INT_DLY_i calculation:

At each transition LV_LSCL_i 0->1, MAF_INT_DLY_i is initialised to 0 and then calculated like this:

$$MAF_INT_DLY_i_n = MAF_INT_DLY_i_{n-1} + MAF_KGH * NC_FAC_MAF_INT$$

$$(NC_FAC_MAF_INT = 20ms/3,6)$$

Deactivation: (LV_LAM_DLY_i = 0)

The function is deactivated if one of the activation condition is not true.

Formula section:

- VLS_DIF_DLY_i calculation :

$$VLS_DIF_DLY_i = IP_VLS_SP_DLY_N_32_MAF - VLS_CAT_i$$

- T_DLY_P_i calculation :

The P-share of the controller is calculated only in a specific N/MAF-areas:

$$C_MAF_LAM_DLY_P_MIN < MAF < C_MAF_LAM_DLY_P_MAX$$

and $C_N_LAM_DLY_P_MIN < N_32 < C_N_LAM_DLY_P_MAX$

When this conditions are not fulfilled or LV_LAM_DLY = 0, the corresponding P-share is initialized with 0.

$$T_DLY_P_i = IP_T_DLY_P_VLS_DLY_i$$

$$* IP_FAC_DLY_P_MAF_KGH$$

$$* IP_FAC_CAT_DLY_CAT_DIAG_TRIM_i$$

Remark: IP_FAC_CAT_DLY is constant for the present driving cycle, even if there is a new CAT_DIAG determination.

- T_DLY_I_i calculation :

The I-share of the controller is calculated only in a specific MAF-area:

$$IP_MAF_LAM_DLY_I_MIN_N_32 < MAF < IP_MAF_LAM_DLY_I_MAX_N_32$$

When this conditions are not fulfilled or LV_LAM_DLY = 0, the corresponding I-share is initialized with 0.

$$T_DLY_I_i_n = T_DLY_I_i_{n-1}$$

$$+ IP_CRLC_DLY_I_MAF_KGH * IP_T_DLY_I_VLS_DIF_DLY_i$$

T_DLY_I_i is limited with following limits:

$$C_T_DLY_I_MIN < T_DLY_I_i < C_T_DLY_I_MAX$$

Editor: Müller O.	17-Dec-97	Injection	HMC_V6
Version: a 153589 from 18.12.97		657765.49.06	
File: CHAP_7.DOC	650H0000	Sourcefile:07702B01.00D	Page 113 / 121

- T_DLY_AD_i calculation :

The AD-share of the controller is calculated only in a specific MAF-area:

$$IP_MAF_LAM_DLY_AD_MIN_N_32 < MAF < IP_MAF_LAM_DLY_AD_MAX_N_32$$

If AD-share calculation is active, then the flag LV_T_DLY_AD_i is set to 1.

$$T_DLY_AD_i_n = T_DLY_AD_i_{n-1} + C_CRLC_DLY_AD * T_DLY_I_i$$

Additionnaly, T_DLY_AD_i is decreased by C_T_DLY_AD_DEC ms each second if LV_T_DLY_AD_i = 1

T_DLY_AD_i is limited with following limits:

$$C_T_DLY_AD_MIN < T_DLY_AD_i < C_T_DLY_AD_MAX$$

At the end of the driving cycle, T_DLY_AD_i is stored in the flash memory. At the beginning of the next driving cycle, T_DLY_AD_i is initialized with this stored value. After ECU reset, T_DLY_AD_i is initialized with 0.

- Global T_LAM_DLY_i calculation :

$$T_LAM_DLY_i = (T_DLY_P_i + T_DLY_I_i + T_DLY_AD_i) * IP_FAC_LAM_DLY_N_32_MAF$$

Calibration data:

Name	Dim	Hex. limits	Phys. limits	Resol.	Unit
C_LAM_TEMP_MIN_CAT_DLY	-	0...FEH	-33...990	4	°C
minimum catalyst temperature model threshold for fuel trim regulation function activation					
C_LAM_TEMP_HYS_CAT_DLY	-	0...FEH	-33...990	4	°C
Hysteresis on minimum catalyst temperature model threshold for fuel trim regulation function activation					
C_MAF_INT_MIN_DLY_PUC	-	0...FFFFH	0...11650,66	0,178	g
threshold for MAF integral while restart of LAM after PUC					
C_MAF_INT_MIN_DLY	-	0...FFFFH	0...11650,66	0,178	g
threshold for MAF integral while restart of LAM after inactive					
C_CAT_DIAG_MAX_DLY	-	0...FFFFH	0...255,996	3,9e-3	-
threshold of catalyst conversion capability for activation					
IP_VLS_SP_DLY_N_32_MAF	4 * 4	0...3FFH	0...4,9805	4,87e-3	V
setpoint for downstream fuel trim controller					
C_MAF_LAM_DLY_P_MIN	-	0...FFFFH	0...1389	0,021	mg/stroke
min MAF threshold for activation P-share					
C_MAF_LAM_DLY_P_MAX	-	0...FFFFH	0...1389	0,021	mg/stroke
max MAF threshold for activation P-share					
C_N_LAM_DLY_P_MIN	-	0...FFH	0...8160	32	1/min
min N threshold for activation P-share					
C_N_LAM_DLY_P_MAX	-	0...FFH	0...8160	32	1/min
max N threshold for activation P-share					

Editor: Müller O.	17-Dec-97	Injection	HMC_V6
Version: a 153589 from 18.12.97		657765.49.06	
File: CHAP_7.DOC	650H0000	Sourcefile:07702B01.00D	Page 114 / 121

Calibration data:

Name	Dim	Hex. limits	Phys. limits	Resol.	Unit
IP_T_DLY_P_VLS_DIF_DLY_i	12	0...FFFFH	-640...639,98	0,0195	ms
LAM - P - jump delay time from P-share					
IP_FAC_DLY_P_MAF_KGH	6	0...FFH	0...0,996	3,9e-3	-
weight factor for P-share regarding engine load and speed conditions					
IP_FAC_CAT_DLY_CAT_DIAG_TRIM_i	6	0...FFH	0...0,996	3,9e-3	-
weight factor for P-share regarding catalyst conversion capability					
IP_MAF_LAM_DLY_I_MIN_N_32	6	0...FFFFH	0...1389	0,021	mg/stroke
min MAF threshold for activation I-share					
IP_MAF_LAM_DLY_I_MAX_N_32	6	0...FFFFH	0...1389	0,021	mg/stroke
max MAF threshold for activation I-share					
IP_T_DLY_I_VLS_DIF_DLY_i	12	0...FFFFH	-640...639,98	0,0195	ms
LAM - P - jump delay time from I-share					
IP_CRLC_DLY_I_MAF_KGH	6	0...FFH	0...0,996	3,9e-3	-
correlation constant for I-share calculation					
C_T_DLY_I_MIN	-	0000...FFFFH	0...1279,98	0,0195	ms
min. limit of I-share					
C_T_DLY_I_MAX	-	0000...FFFFH	0...1279,98	0,0195	ms
max. limit of I-share					
IP_MAF_LAM_DLY_AD_MIN_N_32	6	0...FFFFH	0...1389	0,021	mg/stroke
min MAF threshold for calculation AD-share					
IP_MAF_LAM_DLY_AD_MAX_N_32	6	0...FFFFH	0...1389	0,021	mg/stroke
max MAF threshold for calculation AD-share					
C_T_DLY_AD_DEC	-	8000...7FFFH	-640...639,98	0,0195	ms
Decrement for AD-share					
C_T_DLY_AD_MIN	-	0000...FFFFH	0...1279,98	0,0195	ms
min. limit of AD-share					
C_T_DLY_AD_MAX	-	0000...FFFFH	0...1279,98	0,0195	ms
max. limit of AD-share					
C_CRLC_DLY_AD	-	0...FFH	0...0,996	3,9e-3	-
correlation constant for AD-share calculation					
IP_FAC_LAM_DLY_N_32_MAF	8*8	0...FFH	0...0,996	3,9e-3	-
normalization factor for total LAM -P-jump delay time regarding engine load and speed conditions					

Proprietary data, company confidential. All rights reserved.
 Contient des informations confidentielles de la Siemens AG.
 Comunicado como segredo empresarial. Reservados todos os direitos.
 Confidado como secreto industrial. Nos reservamos todos los derechos.

Weitergabe sowie Vervielfältigung dieser Unterlage, Verwertung und Mitteilung ihres Inhalts ist gestattet, soweit nicht ausdrücklich zugestanden. Zuwiderhandlungen verpflichten zu Schadenersatz. Alle Rechte vorbehalten, insbesondere für den Fall der Patenterteilung oder GM-Entragung.

Editor: Müller O.	17-Dec-97	Injection	HMC_V6
Version: a 153589 from 18.12.97		657765.49.06	
File: CHAP_7.DOC	650H0000	Sourcefile:07702B01.00D	Page 115 / 121

1.3.7 Catalyst enrichment function after PUC phase (CAT - purge function)

Output data:

Name	Mode	Hex. limits	Phys. limits	Resol.	Unit
MAF_INT_PUC_i	V	0...FFFFH	0...11650,67	0,178	g
integral of air mass flow while PUC active					
MAF_INT_DLY_PUC_i	V	0...FFFFH	0...11650,67	0,178	g
rest of the integral of air mass flow until catalyst purge deactivation					
T_DLY_PUC_i	V	0...3FFFH	0...1279,9	0,078	ms
LAM-P-jump delay time of the catalyst purge function					
LV_ACT_INT_PUC_i	V	0...1H	0...1	1	-
status of catalyst purge activation					

Input data:

TCO	CAT_DIAG_TRIM_i	LV_PUC	VLS_CAT_i
MAF_KGH	LV_LSH_CAT_PHA_MAX_RATE		

FUNCTION DESCRIPTION:

General information:

After a fuel cut-off phase (PUC), the catalyst is full with oxygen. The target of this function is to make the lambda regulation a little more rich than normal in order to purge the oxygen contained in the catalyst.

The rich lambda shift is made with a P-jump delay T_DLY_PUC_i.

In order to evaluate the quantity of oxygen contained in the catalyst, air flow during fuel cut-off is integrated by the counter MAF_INT_PUC. The purge phase duration is calculated according to this counter.

If two separate catalyst systems are concerned then

i = 1, for cylinder bank 1

i = 2, for cylinder bank 2

Application conditions:

Activation: -> LV_ACT_INT_PUC_i = 1

- TCO > C_TCO_DLY_PUC_MIN
- and LV_PUC = 1 -> LV_PUC = 0
- and MAF_INT_PUC_i > C_MAF_INT_PUC_MIN
- and MAF_INT_DLY_PUC_i > 0
- and LV_LSH_CAT_PHA_MAX_RATE = 1

Editor: Müller O.	17-Dec-97	Injection	HMC_V6
Version: a 153589 from 18.12.97		657765.49.06	
File: CHAP_7.DOC	650H0000	Sourcefile:07702C01.00D	Page 116 / 121

Proprietary data, company confidential. All rights reserved. Contient des informations confidentielles. Tous droits réservés. Comunicado como segredo empresarial. Reservados todos os direitos. Confidado como secreto industrial. Nos reservamos todos los derechos.

Weitergabe sowie Vervielfältigung dieser Unterlage, Verbreitung und Mitteilung ihres Inhalts nicht gestattet, soweit nicht ausdrücklich zugestanden. Zuwiderhandlungen verpflichten zu Schadenersatz. Alle Rechte vorbehalten, insbesondere für den Fall der Patenterteilung oder GM-Entragung.

Deactivation: -> $LV_ACT_INT_PUC_i = 0$

- $MAF_INT_DLY_PUC_i = 0$
- or $VLS_CAT_i < C_VLS_CAT_DLY_MAX_PUC$ for the first time
- or $LV_PUC = 1$

Formula section:

- MAF_INT_PUC_i calculation:

If $LV_PUC = 1$
and $MAF_INT_PUC_i < \text{max. value (11650,7g)}$

Then

$$MAF_INT_PUC_{n_i} = MAF_INT_PUC_{n-1_i} + MAF_KGH * NC_FAC_MAF_INT$$

Remark:

- MAF_INT_PUC is calculated each 20ms
- MAF_INT_PUC is initialized with 0 at each PUC phase detection

- MAF_INT_DLY_PUC_i calculation:

. At each transition $LV_PUC = 1 \rightarrow LV_PUC = 0$, $MAF_INT_DLY_PUC_i$ is initialized with $IP_MAF_INT_DLY_PUC_MAF_INT_PUC_i$ and limited to $C_MAF_INT_DLY_PUC_MAX$.

. If the catalyst balance function is deactivated by the interruption of the lambda controller due to another PUC phase the initialisation is:

$$MAF_INT_DLY_PUC_{i_new} = IP_MAF_INT_DLY_PUC + MAF_INT_DLY_PUC_{i_old}$$

As long as $LV_PUC = 0$, $MAF_INT_DLY_PUC$ is decreased to 0:

$$MAF_INT_DLY_PUC_{i_n} = MAF_INT_DLY_PUC_{i_{n-1}} - (MAF_KGH * NC_FAC_MAF_INT * IP_FAC_CAT_DLY_PUC)$$

If $VLS_CAT_i < C_VLS_CAT_DLY_MAX_PUC$ then $MAF_INT_DLY_PUC_i$ is reseted to 0.

Remark: $MAF_INT_DLY_PUC$ is calculated each 20ms

- T_DLY_PUC_i calculation:

If $LV_ACT_INT_PUC = 1$

Then

$$T_DLY_PUC_i = IP_T_DLY_PUC_MAF_KGH$$

Else

$$T_DLY_PUC_i = 0$$

Proprietary data, company confidential. All rights reserved. Contine a titre de secret d'entreprise. Tous droits réservés. Comunicado como segredo empresarial. Reservados todos os direitos. Confidado como secreto industrial. Nos reservamos todos los derechos.

Weitergabe sowie Vervielfältigung dieser Unterlage, Verbreitung und Mitteilung ihres Inhalts nicht gestattet, soweit nicht ausdrücklich zugestanden. Zuwiderhandlungen verpflichten zu Schadenersatz. Alle Rechte vorbehalten, insbesondere für den Fall der Patenterteilung oder GM-Entragung.

Editor:	Müller O.	17-Dec-97	Injection	HMC_V6
Version:	a 153589 from 18.12.97		657765.49.06	
File:	CHAP_7.DOC	650H0000	Sourcefile:07702C01.00D	Page 117 / 121

Proprietary data, company confidential. All rights reserved. Contine a titre de secret d'entreprise. Tous droits réservés. Comunicado como segredo empresarial. Reservados todos os direitos. Confidado como secreto industrial. Nos reservamos todos los derechos.

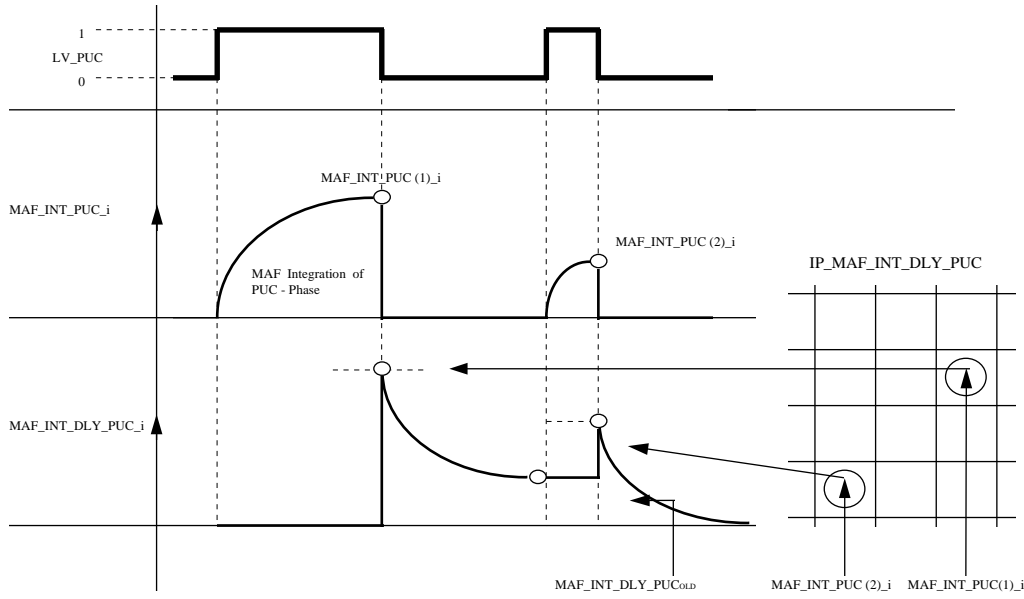

Weitergabe sowie Vervielfältigung dieser Unterlage, Verwertung und Mitteilung ihres Inhalts nicht gestattet, soweit nicht ausdrücklich zugestanden. Zuwiderhandlungen verpflichten zu Schadensersatz. Alle Rechte vorbehalten, insbesondere für den Fall der Patenterteilung oder GM-Eintragung

Calibration data:

Name	Dim	Hex. limits	Phys. limits	Resol.	Unit
C_TCO_DLY_PUC_MIN	-	0...FEH	-48...142,5	0,75	°C
min. TCO threshold for activation					
C_MAF_INT_PUC_MIN	-	0...FFFFH	0...11650,67	0,178	g
min. MAF_INT_PUC threshold for activation					
C_VLS_CAT_DLY_MAX_PUC	-	0...FFH	0...4,98	0,0195	V
max. VLS threshold for deactivation					
IP_MAF_INT_DLY_PUC__MAF_INT_PUC_i	6	0...FFFFH	0...11650,67	0,178	g
initialisation value for the rest of the air mass flow for deactivation					
C_MAF_INT_DLY_PUC_MAX	-	0...FFFFH	0...11650,67	0,178	g
limit value for the rest of the air mass flow for deactivation					
IP_T_DLY_PUC__MAF_KGH	6	0...3FFFH	0...1279,9	0,078	ms
basic LAM-P-jump delay time of the catalyst purge function					
IP_FAC_CAT_DLY_PUC__CAT_DIAG_TRIM_i	6	0...FFH	0...0,996	3.9e-3	-
weight factor of catalyst diagnosis result					

NC_FAC_MAF_INT = 20ms/3,6

Editor: Müller O.	17-Dec-97	Injection	HMC_V6
Version: a 153589 from 18.12.97		657765.49.06	
File: CHAP_7.DOC	650H0000	Sourcefile:07702C01.00D	Page 118 / 121

1.3.7.1 Oxygen-sensor heater downstream from catalyst

Output data:

Name	Mode	Hex. limits	Phys. limits	Resol.	Unit
LSHPWM_CAT_i	V	00...FFH	0...99.609	0.3891	%
Downstream oxygen sensors heating duty cycle					
LSHPWM_CAT_LGRD_i	V	00...FFFFH	0...99.998	1.526E-3	%
Basic downstream oxygen sensors heating duty cycle with gradient limitation.					
LV_LSH_CAT_PHA_MAX_RATE	V	0...01H	0...1	1	-
Boolean to indicate if pre-heating and full heating phases for downstream O2 sensors are finished.					

Input data:

TEMP_MMV_SUB_CAT	VB	N	MAF
LV_ES	LV_ST	LV_VB_JUMP	

FUNCTION DESCRIPTION:

General information:

Downstream O2 sensors heating strategy is working like for the upstream but without heater controller.

In order to avoid big temperature gradient after start, heater power is reduced until the catalyst system has reached its service temperature. Then, heating power is maximum during a time delay in order to reach quickly the target tip-temperature.

After this two phases, heating power is normally calculated from a basic map (cylinder bank individual) weighted by a battery voltage correction. A gradient limitation is applied in negative and positive directions.

Application recurrence :

- Engine stopped: 1 sec.
- Engine running: C_T_PER_LSH_CAT sec.

Formula section:

- LSHPWM_CAT_LGRD_i calculation:

The basic heater power is:

$$IP_LSHPWM_CAT_i_N_32_MAF * IP_LSHPWM_VB_FAC_CAT_VB$$

The result of this multiplication is the target value for LSHPWM_CAT_LGRD_i.

Proprietary data, company confidential. All rights reserved. Contine a titre de secret d'entreprise. Tous droits réservés. Comunicado como segredo empresarial. Reservados todos os direitos. Confidado como secreto industrial. Nos reservamos todos los derechos.

Weitergabe sowie Vervielfältigung dieser Unterlage, Verwertung und Mitteilung ihres Inhalts nicht gestattet, soweit nicht ausdrücklich zugestanden. Zuwiderhandlungen verpflichten zu Schadenersatz. Alle Rechte vorbehalten, insbesondere für den Fall der Patenterteilung oder GM-Entragung.

Editor: Müller O.	17-Dec-97	Injection	HMC_V6
Version: a 153589 from 18.12.97		657765.49.06	
File: CHAP_7.DOC	650H0000	Sourcefile:07702E01.00E	Page 119 / 121

Like for the upstream O2 sensors, a gradient limitation is applied to LSHPWM_CAT_LGRD_i.

If the target value is lower, C_LSHPWM_LGRD_NEG_CAT is used. Otherwise, if the target value is higher, C_LSHPWM_LGRD_POS_CAT is used.

At transition engine stop (LV_ES) to engine start (LV_ST) LSHPWM_CAT_LGRD_i is initialized with C_LSHPWM_CAT_INI_i :

$$\text{LSHPWM_CAT_LGRD_i} = \text{C_LSHPWM_CAT_INI_i}$$

- Heating phases

O2 sensors heating phases are divided in 4 parts:

- Stand-by phase
- Pre-heating phase
- Full heating phase
- Normal heating phase

This phases are performed in a sequential order.

- Stand-by phase:

If Engine stopped (LV_ES) active **or** LV_VB_JUMP = 1 (Active)
then

$$\text{LSHPWM_CAT_i} = \text{NC_LSHPWM_MIN_DIAG}$$

- Pre-heating phase:

If a) Engine stopped (LV_ES) not active **and** LV_VB_JUMP = 0 (Not active)
 b) **and** TEMP_MMV_SUB_CAT < C_TEMP_MIN_SUB_CAT_ST

then

$$\text{LSHPWM_CAT_i} = \text{LSHPWM_CAT_LGRD_i} * \text{C_LSHPWM_T_FAC_CAT} + \text{C_LSHPWM_CAT_i_AS}$$

else

“Full-heating” phase is started

- Full-heating phase:

If Pre-heating phase is finished
 (TEMP_MMV_SUB_CAT > C_TEMP_MIN_SUB_CAT_ST)

then

$$\text{LSHPWM_CAT_i} = \text{NC_LSHPWM_MAX_DIAG}$$

during C_T_MAX_LSH_CAT_ST seconds

When this Full-heating phase is finished, the flag LV_LSH_CAT_PHA_MAX_RATE is set to 1.

- Normal heating phase:

Editor: Müller O.	17-Dec-97	Injection	HMC_V6
Version: a 153589 from 18.12.97		657765.49.06	
File: CHAP_7.DOC	650H0000	Sourcefile:07702E01.00E	Page 120 / 121

If Full heating phase is finished
(time C_T_MAX_LSH_CAT_ST elapsed)

then

$$LSHPWM_CAT_i = LSHPWM_CAT_LGRD_i + C_LSHPWM_CAT_i_AS$$

Remark: At the end of the full-heating phase, LSHPWM CAT LGRD i is set to NC LSHPWM MAX DIAG and decreased to the target LSHPWM CAT i with the specific change limitation C LSHPWM LGRD MAX CAT

Calibration data:

Name	Dim	Hex. limits	Phys. limits	Resol.	Unit
IP_LSHPWM_CAT_1_N_32_MAF	6*6	0...FFH	0...99.6	0.389	%
Basic downstream O2 sensor heating Bank n°1					
IP_LSHPWM_CAT_2_N_32_MAF	6*6	0...FFH	0...99.6	0.389	%
Basic downstream O2 sensor heating Bank n°2					
IP_LSHPWM_VB_FAC_CAT_VB	6	0...FFH	0...3.9844	0.0156	-
Battery voltage weighting factor for basic downstream O2 sensors heating					
C_LSHPWM_LGRD_POS_CAT	-	00...FFFFH	0...99.998	1.526E-3	%
limited gradient for LSHPWM_CAT while incrementation					
C_LSHPWM_LGRD_NEG_CAT	-	00...FFFFH	0...99.998	1.526E-3	%
limited gradient for LSHPWM_CAT while decrementation					
C_LSHPWM_LGRD_MAX_CAT	-	00...FFFFH	0...99.998	1.526E-3	%
limited gradient for LSHPWM_CAT after full heating phase					
C_LSHPWM_CAT_INI_1	1	00...FFH	0...99.6	0.3891	%
Initialisation-value of LSHPWM_CAT_LGRD_1 at transition LV_ES to LV_ST.					
C_LSHPWM_CAT_INI_2	1	00...FFH	0...99.6	0.3891	%
Initialisation-value of LSHPWM_CAT_LGRD_2 at transition LV_ES to LV_ST.					
C_T_PER_LSH_CAT	-	1...FFH	1...255	1	sec
time interval for LSHPWM_CAT calculation					
C_TEMP_MIN_SUB_CAT_ST	-	0...FFH	-33...990	4	°C
Catalyst temperature threshold for ending pre-heating phase					
C_T_MAX_LSH_CAT_ST	-	1...FFH	1...255	1	sec
Full heating phase duration					
C_LSHPWM_T_FAC_CAT	1	1...FFH	0.04...0.996	1/256	-
Weighting factor for basic downstream O2 sensors heating during pre-heating phase					

Applicative Values:

NC_LSHPWM_MIN_DIAG = 2,34%
NC_LSHPWM_MAX_DIAG = 97,26%

Editor: Müller O.	17-Dec-97	Injection	HMC_V6
Version: a 153589 from 18.12.97		657765.49.06	
File: CHAP_7.DOC	650H0000	Sourcefile:07702E01.00E	Page 121 / 121

Document: **Idle Speed**

Project: **Engine Management System**
HMC_V6

Version: a

Date: 17-Dec-97

Number of pages: 60

Revision Code-No.: 153589 from 18.12.97

Construction protocol-No.:

Software version: 650H0000

	Name	Department	Phone	Date	Sign
Author	Müller O.	AT PT SI TSA 11	3211	09.12.97	
1. Check	Pioch O.	AT PT SI TSA 11	3212	09.12.97	
2. Check	Gessner S.	AT PT SI TSA 11	5398	09.12.97	
Responsible	Brückner D.	AT PT SI TSA 16	4279	09.12.97	

Version list

Proprietary data, company confidential. All rights reserved. Contine a titre de secret d'entreprise. Tous droits réservés. Comunicado como segredo empresarial. Reservados todos os direitos. Confidado como secreto industrial. Nos reservamos todos los derechos.

Weitergabe sowie Vervielfältigung dieser Unterlage, Wertung und Mitteilung ihres Inhalts nicht gestattet, soweit nicht ausdrücklich zugestanden. Zuwiderhandlungen verpflichten zu Schadensersatz. Alle Rechte vorbehalten, insbesondere für den Fall der Patenterteilung oder GM-Eintragung

Version	Date	Author	Comment, Description

Editor:	Müller O.	17-Dec-97	Idle Speed	HMC_V6
Version:	a 153589 from 18.12.97		657765.49.07	
File:	CHAP_8.DOC	650H0000		Page 2 / 60

Table of contents

Page

1.1	General	13
1.1.1	Total formulas	13
1.1.1.1	Calculated idle charge actuator opening (ISAPWM)	13
1.1.1.2	Applied idle charge actuator duty cycle (ISAPWM_ISA)	17
1.1.1.3	ISA-opening during powerlatch	18
1.2	Basic idle - charge actuator opening vs. engine point (ISAPWM_TPS)	20
1.3	Basic idle charge actuator opening versus engine load (ISAPWM_TCO_DRI_ACIN)	22
1.4	Idle charge actuator opening with air condition compressor	27
1.5	Basic idle charge actuator opening corr. with catalyst heating (ISAPWM_CH)	31
1.6	Dashpot function (ISAPWM_DHP)	33
1.7	Idle speed regulation correction (ISAPWM_IS)	35
1.7.1	Idle speed regulation limits	39
1.7.1.1	I component limits	39
1.7.1.2	D component limits	40
1.8	Idle speed adaptation (ISAPWM_xx_AD_MMV_IS)	42
1.8.1	General information	42
1.8.2	Adaptation conditions	43
1.8.3	Adaptation sequence	44
1.8.3.1	Adaptation process	44
1.8.3.2	Adaptation calculation	46
1.8.3.3	Adaptation limits	47
1.9	Intake air temperature correction (ISAPWM_TIA_FAC)	49
1.10	Idle-charge Actuator Adaptation (AD_MMV_ISA, ADD_ISA)	50
1.10.1	Adaptation conditions	50
1.10.2	Adaptation of the idle-charge actuator characteristic	52
1.10.3	Initialization of idle-charge actuator adaptation	53
1.11	Fans correction (ISAPWM_CFA, ISAPWM_TRA_CFA)	55
1.12	ISAPWM-correction for programmed idle speed increase	57
1.13	Electrical load correction (ISAPWM_EL_LOAD, ISAPWM_EL_LOAD_TRA)	58
1.14	Automatic gearbox converter load correction	60

Proprietary data, company confidential. All rights reserved.
 Contitit a titre de secret d'entreprise. Tous droits réservés.
 Comunicado como secreto empresarial. Reservados todos os direitos.
 Confidado como secreto industrial. Nos reservamos todos los derechos.

Weitergabe sowie Vervielfältigung dieser Unterlage, Verwertung und Mitteilung ihres Inhalts nicht gestattet, soweit nicht ausdrücklich zugestanden. Zuwiderhandlungen verpflichten zu Schadenersatz. Alle Rechte vorbehalten, insbesondere für den Fall der Patenterteilung oder GM-Entragung.

Editor:	Müller O.	17-Dec-97	Idle Speed	HMC_V6
Version:	a 153589 from 18.12.97		657765.49.07	
File:	CHAP_8.DOC	650H0000		Page 3 / 60

Index	Page
A	
AD_INI_COR_ISA	
def.....	50
AD_MMV_ISA	
def.....	50
ADD_ISA	
def.....	50
C	
C_AD_ADD_MMV_ISA	
def.....	54
C_AD_CRLC_IS	
def.....	48
C_AD_CRLC_ISA	
def.....	54
C_AD_DIF_MMV_ISA	
def.....	54
C_CYCNR_DYW_IS	
def.....	48
C_ISAPWM_0_1_CFA	
def.....	56
C_ISAPWM_0_2_CFA	
def.....	56
C_ISAPWM_0_3_CFA	
def.....	56
C_ISAPWM_1_1_CFA	
def.....	56
C_ISAPWM_1_2_CFA	
def.....	56
C_ISAPWM_1_3_CFA	
def.....	56
C_ISAPWM_ACCIN_AD_FAC	
def.....	48
C_ISAPWM_ACCIN_AD_MAX_IS	
def.....	48
C_ISAPWM_ACCIN_AD_MIN_IS	
def.....	48
C_ISAPWM_ACCIN_DEC_TRA	
def.....	30
C_ISAPWM_ACCIN_LGRD	
def.....	30
C_ISAPWM_ACCIN_MAX_I	
def.....	41, 48
C_ISAPWM_ACCIN_MIN_I	
def.....	41, 48
C_ISAPWM_ACIN_LGRD_DEC_IS	
def.....	26
C_ISAPWM_ACIN_LGRD_INC_IS	
def.....	26
C_ISAPWM_AD_DYW_IS	
def.....	48
C_ISAPWM_AD_MAX_IS	

Editor: Müller O.	17-Dec-97	Idle Speed	HMC_V6
Version: a 153589 from 18.12.97		657765.49.07	
File: CHAP_8.DOC	650H0000	Page 4 / 60	

def.....	48
C_ISAPWM_AD_MAX_ISA	
def.....	54
C_ISAPWM_AD_MIN_IS	
def.....	48
C_ISAPWM_AD_MIN_ISA	
def.....	54
C_ISAPWM_CRLC_IS	
def.....	48
C_ISAPWM_DEC_CFA	
def.....	56
C_ISAPWM_DRI_DEC_TRA	
def.....	26
C_ISAPWM_DRI_INC_TRA	
def.....	26
C_ISAPWM_EL_LOAD	
def.....	59
C_ISAPWM_EL_LOAD_TRA_DEC	
def.....	59
C_ISAPWM_EL_LOAD_TRA_INC	
def.....	59
C_ISAPWM_EL_LOAD_TRA_LGRD	
def.....	59
C_ISAPWM_I_ADD	
def.....	41
C_ISAPWM_INC_0_CFA	
def.....	56
C_ISAPWM_INC_1_CFA	
def.....	56
C_ISAPWM_LGRD	
def.....	41
C_ISAPWM_LGRD_0_CFA	
def.....	56
C_ISAPWM_LGRD_1_CFA	
def.....	56
C_ISAPWM_LGRD_CH	
def.....	32
C_ISAPWM_LGRD_D	
def.....	41
C_ISAPWM_LGRD_DEC_CFA	
def.....	56
C_ISAPWM_MAX_I	
def.....	41, 48
C_ISAPWM_MAX_I_IS	
def.....	41
C_ISAPWM_MIN_I	
def.....	41, 48
C_ISAPWM_MIN_I_IS	
def.....	41
C_ISAPWM_N_ADD_ON	
def.....	38
C_ISAPWM_N_GRD_I_ADD	
def.....	41
C_ISAPWM_VS_ACCIN_MAX_I_IS	
def.....	41
C_ISAPWM_VS_ACCIN_MIN_I_IS	
def.....	41

Editor: Müller O.	17-Dec-97	Idle Speed	HMC_V6
Version: a 153589 from 18.12.97		657765.49.07	
File: CHAP_8.DOC	650H0000		Page 5 / 60

Proprietary data, company confidential. All rights reserved.
 Contient des informations confidentielles. Tous droits réservés.
 Comunicado como segredo empresarial. Reservados todos os direitos.
 Confidado como secreto industrial. Nos reservamos todos los derechos.

Weitergabe sowie Vervielfältigung dieser Unterlage, Verwertung und Mitteilung ihres Inhalts ist gestattet, soweit nicht ausdrücklich zugestanden. Zuwiderhandlungen verpflichten zu Schadensersatz. Alle Rechte vorbehalten, insbesondere für den Fall der Patenterteilung oder GM-Enttragung

C_ISAPWM_VS_MAX_I_IS	
def.....	41
C_ISAPWM_VS_MIN_I_IS	
def.....	41
C_LGRD_ISA_PWL	
def.....	19
C_MAF_AD_ISA	
def.....	54
C_MAF_MAX_ISA	
use.....	50
C_N_AD_DYW_IS	
def.....	48
C_N_DIF_MIN_IS	
def.....	38
C_N_MAX_INF	
use.....	39
C_T_ACCIN_FAC_INC	
def.....	30
C_T_ACCIN_FAC_ON	
def.....	30
C_T_ISA_OPEN_DLY	
def.....	19
C_T_MAX_IS	
def.....	41
C_T_MIN_D_ISA	
use.....	39
C_T_MIN_RIS	
def.....	38
C_TCO_ACCIN_AD_MIN_IS	
def.....	48
C_TCO_AD_MAX_IS	
def.....	48
C_TCO_AD_MIN_IS	
def.....	48
D	
DRI_N_SP_ADD_CH	
use.....	31
I	
ID_CYCNR_IS__N	
use.....	50
ID_CYCNR_IS__N_32	
def.....	48
IGA_CH	
use.....	31
IP_AD_INI_ISA__TIA	
def.....	54
IP_ISAPWM(_AT)__TCO	
def.....	26
IP_ISAPWM_ACCIN__TIA__LV_PRS_ACC	
def.....	30
IP_ISAPWM_ACCIN_N_MAF__N__MAF__ALTI_COR	
def.....	30
IP_ISAPWM_ACCIN_N_MAF__N__SP_IS__MAF__ALTI_COR	
use.....	42
IP_ISAPWM_ACCIN_TRA__N	

Editor: Müller O.	17-Dec-97	Idle Speed	HMC_V6
Version: a 153589 from 18.12.97		657765.49.07	
File: CHAP_8.DOC	650H0000		Page 6 / 60

def.....	30
IP_ISAPWM_ACCIN_TRA__N_SP_IS	
def.....	30
IP_ISAPWM_ACIN(AT)__TCO	
def.....	26
IP_ISAPWM_ALTI_MAF_FAC_ALTI_MMV	
def.....	26
IP_ISAPWM_COR_ISA__ISAPWM__VB	
def.....	17
IP_ISAPWM_D_IS__N_GRD	
def.....	38
IP_ISAPWM_DHP(AT)__N_32__TPS	
def.....	34
IP_ISAPWM_DRI__TCO__TEMP_AT	
def.....	26
IP_ISAPWM_DRI_ACCIN_ALTI_MAF_FAC_ALTI_MMV	
def.....	30
IP_ISAPWM_DRI_ACIN__TCO__TEMP_AT	
def.....	26
IP_ISAPWM_DRI_LGRD_DEC__TCO	
def.....	26
IP_ISAPWM_DRI_LGRD_INC__TCO	
def.....	26
IP_ISAPWM_DRI_N__TCO__DRI_N_SP_ADD_CH	
def.....	32
IP_ISAPWM_DRI_TRA_1__TCO	
def.....	26
IP_ISAPWM_DRI_TRA_2__TCO	
def.....	26
IP_ISAPWM_FAC_CH__TCO__T_AST	
def.....	21
IP_ISAPWM_FAC_N_SP_IS_ASA__TCO	
def.....	57
IP_ISAPWM_IGA__TCO__IGA_CH	
def.....	32
IP_ISAPWM_INI_I_ST__TCO__MAF_FAC_ALTI_MMV	
def.....	38
IP_ISAPWM_LGRD__N_32	
def.....	34
IP_ISAPWM_LGRD_ST__TCO	
def.....	16
IP_ISAPWM_LOAD_AT_FAC__LOAD_AT__TCO	
def.....	60
IP_ISAPWM_N__TCO__N_SP_ADD_CH	
def.....	32
IP_ISAPWM_N_SP_IS_ASA__N_SP_IS_ADJ_ASA	
def.....	57
IP_ISAPWM_NEG_I_IS__N_DIF_COR	
def.....	38
IP_ISAPWM_P_IS__N_DIF_COR	
def.....	38
IP_ISAPWM_POS_I_IS__N_DIF_COR	
def.....	38
IP_ISAPWM_ST__N__TCO	
def.....	16
IP_ISAPWM_TCO_FAC_IS__TCO	
def.....	38

Editor: Müller O.	17-Dec-97	Idle Speed	HMC_V6
Version: a 153589 from 18.12.97		657765.49.07	
File: CHAP_8.DOC	650H0000		Page 7 / 60

Proprietary data, company confidential. All rights reserved.
 Contient des données confidentielles de l'entreprise. Tous droits réservés.
 Comunicado como secreto empresarial. Reservados todos los derechos.
 Confiado como secreto industrial. Nos reservamos todos los derechos.

Weitergabe sowie Vervielfältigung dieser Unterlage, Verwertung und Mitteilung ihres Inhalts nicht gestattet, soweit nicht ausdrücklich zugestanden. Zuwiderhandlungen verpflichten zu Schadensersatz. Alle Rechte vorbehalten, insbesondere für den Fall der Patenterteilung oder GM-Entragung

IP_ISAPWM_TIA_FAC_TIA	
def.....	49
IP_ISAPWM_TPS_N_32_TPS	
def.....	21
IP_ISAPWM_TPS_CH_N_32_TPS	
def.....	21
IP_ISAPWM_TPS_DRI_N_32_TPS	
def.....	21
IP_MAF_AD_MAX_ISA_N_32	
def.....	54
ISAPWM	
def.....	13
use.....	17, 33, 35, 39, 50
ISAPWM_ACCIN.....	27
use.....	13
ISAPWM_ACCIN_AD_MMV_IS.....	42
use.....	27
ISAPWM_AD_COR_IS.....	42
use.....	35, 39
ISAPWM_AD_IS.....	42
ISAPWM_AD_MMV_IS.....	42
use.....	13
ISAPWM_AS	
use.....	13
ISAPWM_CFA	
def.....	55
use.....	13
ISAPWM_CH	
def.....	31
use.....	13
ISAPWM_D_IS	
def.....	35
use.....	39
ISAPWM_DHP	
def.....	33
use.....	13
ISAPWM_DRI_AD_MMV_IS.....	42
use.....	13
ISAPWM_DRI_TRA	
def.....	22
use.....	13
ISAPWM_EL_LOAD	
def.....	58
ISAPWM_EL_LOAD_TRA	
def.....	58
ISAPWM_FAC_ST	
use.....	13
ISAPWM_I_IS	
def.....	35
use.....	39
ISAPWM_IGA_CH	
def.....	31
ISAPWM_IS	
def.....	35
use.....	13, 42
ISAPWM_ISA	
def.....	17

Editor: Müller O.	17-Dec-97	Idle Speed	HMC_V6
Version: a 153589 from 18.12.97		657765.49.07	
File: CHAP_8.DOC	650H0000		Page 8 / 60

Proprietary data, company confidential. All rights reserved.
 Contient des données confidentielles de l'entreprise. Tous droits réservés.
 Comunicado como secreto empresarial. Reservados todos os direitos.
 Confidado como secreto industrial. Nos reservamos todos los derechos.

Weitergabe sowie Vervielfältigung dieser Unterlage, Verwertung und Mitteilung ihres Inhalts nicht gestattet, soweit nicht ausdrücklich zugestanden. Zuwiderhandlungen verpflichten zu Schadensersatz. Alle Rechte vorbehalten, insbesondere für den Fall der Patenterteilung oder GM-Entragung

ISAPWM_LOAD_AT_FAC.....	60
use.....	22
ISAPWM_LOAD_EL.....	
use.....	13
ISAPWM_LOAD_EL_TRA.....	
use.....	13
ISAPWM_MMV_IS.....	42
ISAPWM_N_SP_ADD_CH.....	
def.....	31
ISAPWM_N_SP_IS_ASA.....	
def.....	57
use.....	13
ISAPWM_P_IS.....	
def.....	35
use.....	39
ISAPWM_SAP.....	
use.....	13
ISAPWM_TCO_DRI_ACIN.....	
def.....	22
use.....	13, 60
ISAPWM_TIA_FAC.....	
def.....	49
use.....	13, 50
ISAPWM_TPS.....	
def.....	20
use.....	13
ISAPWM_TRA_ACCIN.....	27
use.....	13, 42
ISAPWM_TRA_CFA.....	
def.....	55
use.....	13
ISAPWM_TRA_SAP.....	
use.....	13
L	
LOAD_AT.....	
def.....	60
LV_ACCIN.....	
use.....	27, 55
LV_ACIN.....	
use.....	22, 39
LV_AD_PREV_ISA.....	
def.....	50
LV_CPS_ERR.....	
use.....	42
LV_CPS_MECHA_ERR.....	
use.....	42
LV_CT.....	
use.....	39, 42, 50
LV_DRI.....	
use.....	20, 31, 42
LV_DRI_ISAPWM.....	
use.....	22, 27, 60
LV_DUR_IGC_[CYL]_ERR.....	
use.....	42
LV_EL_LOAD.....	
use.....	58

Editor: Müller O.	17-Dec-97	Idle Speed	HMC_V6
Version: a 153589 from 18.12.97		657765.49.07	
File: CHAP_8.DOC	650H0000		Page 9 / 60

Proprietary data, company confidential. All rights reserved.
 Contient des données confidentielles de l'entreprise. Tous droits réservés.
 Comunicado como segredo empresarial. Reservados todos os direitos.
 Confidado como secreto industrial. Nos reservamos todos los derechos.

Weitergabe sowie Vervielfältigung dieser Unterlage, Verwertung und Mitteilung ihres Inhalts nicht gestattet, soweit nicht ausdrücklich zugestanden. Zuwiderhandlungen verpflichten zu Schadensersatz. Alle Rechte vorbehalten, insbesondere für den Fall der Patenterteilung oder GM-Entragung.

LV_ES	
use.....	13, 18, 35, 42, 50
LV_IGA_CH	
use.....	20, 31
LV_IGK	
use.....	17, 18
LV_INF	
use.....	39
LV_IS	
use.....	22, 31, 35, 39, 42
LV_ISA_i_ERR	
use.....	42, 50
LV_ISA_MECHA_ERR	
use.....	42, 50
LV_ISAPWM_AD_DYW_IS	
def.....	42
LV_ISAPWM_IS_ACT	
def.....	35
LV_IV_[CYL]_ERR	
use.....	42
LV_LAM_LIM_i_ERR	
use.....	42
LV_MAF_AD_MAX_ISA	
def.....	50
LV_MAF_ERR	
use.....	42, 50
LV_MAF_PLAUS_ERR	
use.....	42, 50
LV_N_AD_DYW_IS	
def.....	42
LV_N_SP_ADD_CH	
use.....	31
LV_PRS_ACC	
use.....	27, 55
LV_PU	
use.....	39
LV_RLY_ACCOUT_CTRL	
use.....	27, 42
LV_ST	
use.....	13, 35, 39, 42
LV_STATE_A_MIS	
use.....	42
LV_TCO_ERR	
use.....	42
LV_TCO_PLAUS_ERR	
use.....	42
LV_TIA_ERR	
use.....	42, 50
LV_TIMEOUT_TCU1_ERR	
use.....	42
LV_TPS_ERR	
use.....	42, 50
LV_TPS_PLAUS_ERR	
use.....	42, 50
LV_VLS_LIM_i_ERR	
use.....	42
LV_VLS_UP_i_ERR	

Editor:	Müller O.	17-Dec-97	Idle Speed	HMC_V6
Version:	a 153589 from 18.12.97		657765.49.07	
File:	CHAP_8.DOC	650H0000		Page 10 / 60

Proprietary data, company confidential. All rights reserved.
 Contit a titre de secret d'entreprise. Tous droits réservés.
 Comunicado como segredo empresarial. Reservados todos os direitos.
 Confidado como secreto industrial. Nos reservamos todos los derechos.

Weitergabe sowie Vervielfältigung dieser Unterlage, Verwertung und Mitteilung ihres Inhalts nicht gestattet, soweit nicht ausdrücklich zugestanden. Zuwiderhandlungen verpflichten zu Schadensersatz. Alle Rechte vorbehalten, insbesondere für den Fall der Patenterteilung oder GM-Enttragung

use.....	42
LV_VS_ERR	
use.....	42
M	
MAF	
use.....	50
MAF_ALTI_COR	
use.....	27, 50
MAF_FAC_ALTI_MMV	
use.....	22, 27, 35
MAF_KGH	
use.....	50
N	
N	
use.....	17, 22, 27, 35, 42, 60
N_32	
use.....	20, 27, 33, 39, 42, 50
N_CONV	
def.....	60
N_DIF_COR	
use.....	35
N_GRD	
use.....	35, 39
N_SP_ADD_CH	
use.....	31
N_SP_IS	
use.....	27, 35, 42
N_SP_IS_ADJ_ASA	
use.....	57
NC_ISAPWM_N_MAX	
use.....	13, 17, 22, 27, 35, 42
P	
PWL_DLY_CTR	
def.....	18
S	
STATE_CFA_IS	
use.....	55
T	
T_AST	
use.....	20
TCO	
use.....	20, 22, 31, 35, 42, 57, 60
TEMP_AT	
use.....	22
TIA	
use.....	27, 49, 50
TPS	
use.....	20, 33, 50
V	
VB	
use.....	17, 42
VS	
use.....	39, 42

Editor: Müller O.	17-Dec-97	Idle Speed	HMC_V6
Version: a 153589 from 18.12.97		657765.49.07	
File: CHAP_8.DOC	650H0000		Page 11 / 60

VS_STATE_CFA

use.....55

Proprietary data, company confidential. All rights reserved.
 Contitit a titre de secret d'entreprise. Tous droits réservés.
 Comunicado como segredo empresarial. Reservados todos os direitos.
 Confidado como secreto industrial. Nos reservamos todos los derechos.

Weitergabe sowie Vervielfältigung dieser Unterlage, Verwertung und Mitteilung ihres Inhalts nicht gestattet, soweit nicht ausdrücklich zugestanden. Zuwiderhandlungen verpflichten zu Schadensersatz. Alle Rechte vorbehalten, insbesondere für den Fall der Patenterteilung oder GM-Eintragung

Editor:	Müller O.	17-Dec-97	Idle Speed	HMC_V6
Version:	a 153589 from 18.12.97		657765.49.07	
File:	CHAP_8.DOC	650H0000		Page 12 / 60

1.1 General

1.1.1 Total formulas

1.1.1.1 Calculated idle charge actuator opening (ISAPWM)

Output data:

Name	Mode	Hex. limits	Phys. limits	Resol.	Unit
ISAPWM	V	00...FFFFH	0...99,998	1,526E-3	%
Calculated idle speed valve opening.					

Input data:

ISAPWM_TPS	ISAPWM_TCO_DRI_ACIN	ISAPWM_IS	ISAPWM_DHP
ISAPWM_SAP	ISAPWM_TRA_SAP	ISAPWM_CFA	ISAPWM_TRA_CFA
ISAPWM_AD_MMV_IS	ISAPWM_DRI_AD_MMV_IS	ISAPWM_AS	ISAPWM_FAC_ST
ISAPWM_CH	ISAPWM_TRA_ACCIN	ISAPWM_ACCIN	ISAPWM_TIA_FAC
NC_ISAPWM_N_MAX	LV_ES	LV_ST	ISAPWM_N_SP_IS_ASA
ISAPWM_LOAD_EL	ISAPWM_LOAD_EL_TRA	ISAPWM_DRI_TRA	

FUNCTION DESCRIPTION:

General information:

The ISAPWM takes any value from **0** to **100 %**.

The linear opening ratio is converted to standard conditions TIA = 20 °C (intake air temperature) by means of air-density correction ISAPWM_TIA_FAC.

A special ISAPWM calculation is used in case of Engine Stopped or Start. When engine operating state Start is exited, the normal ISAPWM is reached with a change limitation.

If $N < NC_ISAPWM_N_MAX$ the application recurrence is **10 msec**, otherwise **40 msec**.

Proprietary data, company confidential. All rights reserved.
 Contient a titre de secret d'entreprise. Tous droits réservés.
 Comunicado como secreto empresarial. Reservados todos os direitos.
 Confidado como secreto industrial. Nos reservamos todos los derechos.

Weitergabe sowie Vervielfältigung dieser Unterlage, Verbreitung und Mitteilung ihres Inhalts nicht gestattet, soweit nicht ausdrücklich zugestanden. Zuwiderhandlungen verpflichten zu Schadenersatz. Alle Rechte vorbehalten, insbesondere für den Fall der Patenterteilung oder GM-Entragung.

Editor: Müller O.	17-Dec-97	Idle Speed	HMC_V6
Version: a 153589 from 18.12.97		657765.49.07	
File: CHAP_8.DOC	650H0000	Sourcefile:07800101.00K	Page 13 / 60

Formula section:

If (LV_ES = 1 or LV_ST = 1)

Then

ISAPWM = IP_ISAPWM_ST__N__TCO

Else

ISAPWM = (ISAPWM_TPS	Basic ISAPWM versus engine operating point.	
+	ISAPWM_TCO_DRI_ACIN	Basic ISAPWM versus engine load.	
+	ISAPWM_DRI_TRA	Transient correction when Drive is engaged	
+	ISAPWM_IS	Global idle speed regulation.	
+	ISAPWM_DHP	Dashpot correction.	
+	ISAPWM_CH	Catalyst heating function correction	
+	ISAPWM_SAP	Secondary air global correction.	
+	ISAPWM_TRA_SAP	Secondary air transient correction.	
+	ISAPWM_CFA	Fans global correction.	
+	ISAPWM_TRA_CFA	Fans transient correction.	
or	+	ISAPWM_AD_MMV_IS	Idle speed adaptation correction without DRIVE engaged.
or	+	ISAPWM_DRI_AD_MMV_IS	Idle speed adaptation correction with DRIVE engaged.
	+	ISAPWM_ACCIN	Air condition global correction.
	+	ISAPWM_TRA_ACCIN	Air condition transient correction.
	+	ISAPWM_LOAD_EL	Electrical load correction.
	+	ISAPWM_LOAD_EL_TRA	Electrical load transient correction.
	+	ISAPWM_AS	Adjustment via application system.
	+	ISAPWM_N_SP_IS_ASA)	Correction for programmed idle speed increase
	* ISAPWM_TIA_FAC	Intake air temperature correction.	

Transition from ISAPWM in Start to ISAPWM out of Start is performed with the change limitation IP_ISAPWM_LGRD_ST__TCO.

Proprietary data, company confidential. All rights reserved. Contine a titre de secret d'entreprise. Tous droits réservés. Comunicado como segredo empresarial. Reservados todos os direitos. Confidado como secreto industrial. Nos reservamos todos los derechos.

Weitergabe sowie Vervielfältigung dieser Unterlage, Verwertung und Mitteilung ihres Inhalts nicht gestattet, soweit nicht ausdrücklich zugestanden. Zuwiderhandlungen verpflichten zu Schadenersatz. Alle Rechte vorbehalten, insbesondere für den Fall der Patenterteilung oder GM-Entragung.

Editor: Müller O.	17-Dec-97	Idle Speed	HMC_V6
Version: a 153589 from 18.12.97		657765.49.07	
File: CHAP_8.DOC	650H0000	Sourcefile:07800101.00K	Page 14 / 60

Proprietary data, company confidential. All rights reserved.
 Contient des informations confidentielles. Tous droits réservés.
 Comunicado como segredo empresarial. Reservados todos os direitos.
 Confidado como secreto industrial. Nos reservamos todos los derechos.

Weitergabe sowie Vervielfältigung dieser Unterlage, Verwertung und Mitteilung ihres Inhalts nicht gestattet, soweit nicht ausdrücklich zugestanden. Zuwiderhandlungen verpflichten zu Schadensersatz. Alle Rechte vorbehalten, insbesondere für den Fall der Patenterteilung oder GM-Entragung.

Basic ISAPWM versus operating point (N and TPS if no MTIA/ETC system)

Basic ISAPWM versus engine load

Transient correction when Drive engaged

Dashpot function

Idle speed regulation

Idle speed adaption correction

Secondary air global correction

Secondary air transient correction

Cooling air global correction

Cooling air transient correction

Air condition global correction

Air condition transient correction

Electrical load correction

Electrical load transient correction

Adjustment via Application system

Correction for programmed idle speed increase

Intake air temperature correction

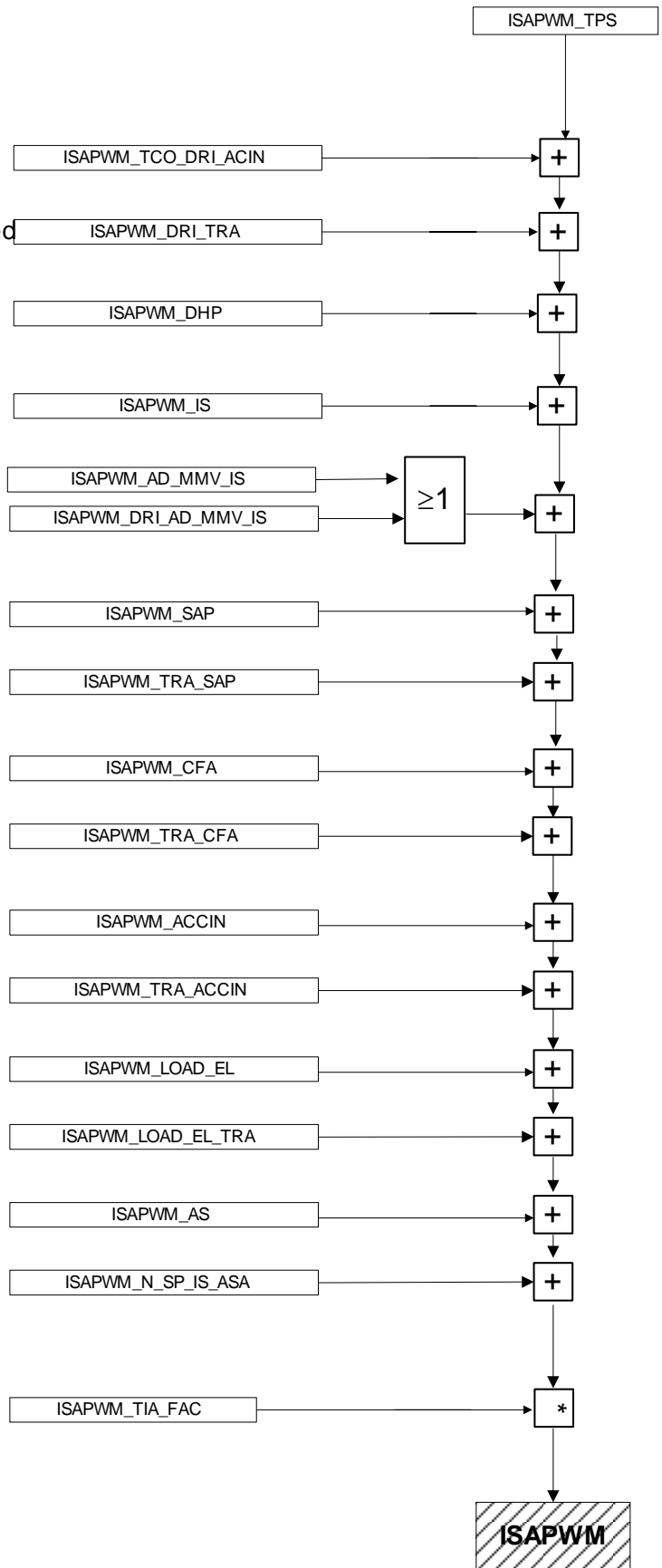

Editor: Müller O.	17-Dec-97	Idle Speed	HMC_V6
Version: a 153589 from 18.12.97		657765.49.07	
File: CHAP_8.DOC	650H0000	Sourcefile:07800101.00K	Page 15 / 60

Proprietary data, company confidential. All rights reserved.
 Contient des données confidentielles. Tous droits réservés.
 Comunicado como secreto empresarial. Reservados todos los derechos.
 Confiado como secreto industrial. Nos reservamos todos los derechos.

Weitergabe sowie Vervielfältigung dieser Unterlage, Verwertung und Mitteilung ihres Inhalts nicht gestattet, soweit nicht ausdrücklich zugestanden. Zuwiderhandlungen verpflichten zu Schadensersatz. Alle Rechte vorbehalten, insbesondere für den Fall der Patenterteilung oder GM-Eintragung.

Calibration data:

Name	Dim	Hex. limits	Phys. limits	Resol.	Unit
IP_ISAPWM_ST__N__TCO	5 * 8	0...FFFFH	0...99,998	0,001526	%
Idle speed valve opening during Start					
IP_ISAPWM_LGRD_ST__TCO	6	01...FFH	0,024...6,226	0,0244	%
Idle speed valve opening change limitation when exiting from Start					

Editor: Müller O.	17-Dec-97	Idle Speed	HMC_V6
Version: a 153589 from 18.12.97		657765.49.07	
File: CHAP_8.DOC	650H0000	Sourcefile:07800101.00K	Page 16 / 60

1.1.1.2 Applied idle charge actuator duty cycle (ISAPWM_ISA)

Output data:

Name	Mode	Hex. limits	Phys. limits	Resol.	Unit
ISAPWM_ISA	V	00...FFFFH	0...99,998	1,526E-3	%
Applied idle charge actuator duty cycle.					

Input data:

NC_ISAPWM_N_MAX	ISAPWM	LV_IGK	N
VB			

FUNCTION DESCRIPTION:

General information:

The duty cycle ISAPWM_ISA represents the command for the idle - charge actuator. The map IP_ISAPWM_COR_ISA_ISAPWM_VB linearizes the idle - charge actuator characteristic.

Furthermore, the opening range (**0...100 %**) is compressed to the working range of the idle charge actuator.

If $N < NC_ISAPWM_N_MAX$, the application recurrence is **10 msec**, otherwise **40 msec**.

Formula section:

ISAPWM_ISA = IP_ISAPWM_COR_ISA_ISAPWM_VB Characteristic linearization.

Remark :

In case of ignition key off (LV_IGK = Passive), the idle charge actuator is driven by **ISAPWM = 0**.

Calibration data:

Name	Dim	Hex. limits	Phys. limits	Resol.	Unit
IP_ISAPWM_COR_ISA_ISAPWM_VB	8*6	00...FFFFH	0...99,998	1,526E-3	%
Idle charge actuator characteristic linearization					

Proprietary data, company confidential. All rights reserved. Contient des informations confidentielles de la société. Tous droits réservés. Comunicado como segredo empresarial. Reservados todos os direitos. Confidado como secreto industrial. Nos reservamos todos los derechos.

Weitergabe sowie Vervielfältigung dieser Unterlage, Verwertung und Mitteilung ihres Inhalts ist gestattet, soweit nicht ausdrücklich zugestanden. Zuwiderhandlungen verpflichten zu Schadensersatz. Alle Rechte vorbehalten, insbesondere für den Fall der Patenterteilung oder GM-Entragung.

Editor: Müller O.	17-Dec-97	Idle Speed	HMC_V6
Version: a 153589 from 18.12.97		657765.49.07	
File: CHAP_8.DOC	650H0000	Sourcefile:07800101.00K	Page 17 / 60

1.1.1.3 ISA-opening during powerlatch

Output data:

Name	Mode	Hex. limits	Phys. limits	Resol.	Unit
PWL_DLY_CTR	1u	0...FFH	0...255	1	-
Powerlatch delay counter					

Input data:

LV_IGK	LV_ES		

FUNCTION DESCRIPTION:

General information:

In order to clean the idle speed valve from deposits it is opened by ramp to 100% duty cycle during powerlatch. The opening ramp starts after a delay time to equalize the intake manifold pressure before.

Formula section:

If LV_IGK = 0
and LV_ES = 1
then PWL_DLY_CTR = PWL_DLY_CTR + 1
and
if C_T_ISA_OPEN_DLY is elapsed
then ISA is closed and opened afterwards to 100%. After reaching 100% it is closed again. All transitions use the change limitation C_LGRD_ISA_PWL.
 When 0% are reached at the end, the PWL_DLY_CTR = PWL_DLY_CTR - 1.
 (See diagram)

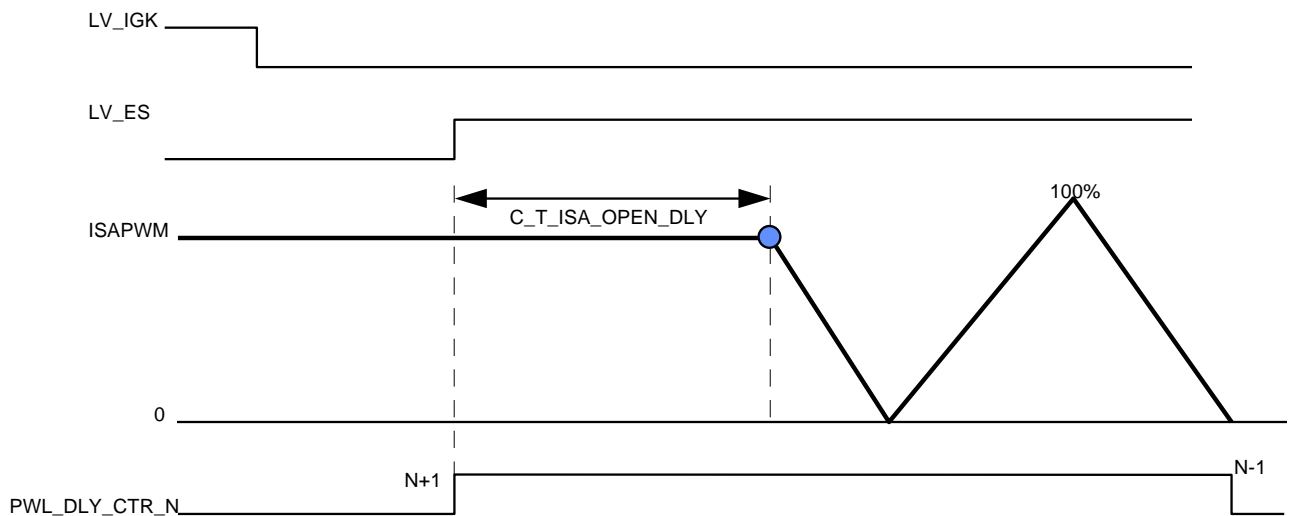

Proprietary data, company confidential. All rights reserved. Contine a titre de secret d'entreprise. Tous droits réservés. Comunicado como segredo empresarial. Reservados todos os direitos. Confidado como secreto industrial. Nos reservamos todos los derechos.

Weitergabe sowie Vervielfältigung dieser Unterlage, Verwertung und Mitteilung ihres Inhalts nicht gestattet, soweit nicht ausdrücklich zugestanden. Zuwiderhandlungen verpflichten zu Schadensersatz. Alle Rechte vorbehalten, insbesondere für den Fall der Patenterteilung oder GM-Entragung.

Editor: Müller O.	17-Dec-97	Idle Speed	HMC_V6
Version: a 153589 from 18.12.97		657765.49.07	
File: CHAP_8.DOC	650H0000	Sourcefile:07800101.00K	Page 18 / 60

Calibration data:

Name	Dim	Hex. limits	Phys. limits	Resol.	Unit
C_T_ISA_OPEN_DLY	1u	00...FFH	0...255	1	s
Delay to open ISA after engine stop.					
C_LGRD_ISA_PWL	2u	1...FFFFH	1,5E-3...100	1,526E-3	%/10ms
Change limitation to open and close ISA during powerlatch					

Proprietary data, company confidential. All rights reserved.
 Contient des données confidentielles de l'entreprise. Tous droits réservés.
 Comunicado como secreto empresarial. Reservados todos los derechos.
 Confiado como secreto industrial. Nos reservamos todos los derechos.

Weitergabe sowie Vervielfältigung dieser Unterlage, Wertung und Mitteilung ihres Inhalts nicht gestattet, soweit nicht ausdrücklich zugestanden. Zuwiderhandlungen verpflichten zu Schadensersatz. Alle Rechte vorbehalten, insbesondere für den Fall der Patenterteilung oder GM-Eintragung.

Editor: Müller O.	17-Dec-97	Idle Speed	HMC_V6
Version: a 153589 from 18.12.97		657765.49.07	
File: CHAP_8.DOC	650H0000	Sourcefile:07800101.00K	Page 19 / 60

1.2 Basic idle - charge actuator opening vs. engine point (ISAPWM_TPS)

Output data:

Name	Mode	Hex. limits	Phys. limits	Resol.	Unit
ISAPWM_TPS	V	0...FFFFH	-9,9218 ...80,0767	0,0015	%
Basic idle - charge actuator opening versus engine operating point.					

Input data:

N_32	LV_IGA_CH	TPS	TCO
T_AST	LV_DRI		

FUNCTION DESCRIPTION:

General information:

This term determines the vacuum in the intake pipe while the throttle is closed (vacuum limitation at trailing throttle).

The change of ISAPWM via the throttle position TPS affects the throttle progression.

An offset is applied when catalyst heating function is active. This offset is used to take into account the ignition angle reduction in part Load.

- The application recurrency is **40 msec**.

Application conditions:

Available for all engine operating states.

Formula section:

- **If** LV_IGA_CH = 0 and LV_DRI = 0
then ISAPWM_TPS = IP_ISAPWM_TPS__N_32__TPS
- **If** LV_IGA_CH = 0 and LV_DRI = 1
then ISAPWM_TPS = IP_ISAPWM_TPS_DRI__N_32__TPS
- **If** LV_IGA_CH = 1 and LV_DRI = 0
then ISAPWM_TPS = IP_ISAPWM_TPS__N_32__TPS
+ IP_ISAPWM_TPS_CH__N_32__TPS * IP_ISAPWM_FAC_CH__TCO__T_AST
- **If** LV_IGA_CH = 1 and LV_DRI = 1
then ISAPWM_TPS = IP_ISAPWM_TPS_DRI__N_32__TPS
+ IP_ISAPWM_TPS_CH__N_32__TPS * IP_ISAPWM_FAC_CH__TCO__T_AST

Editor: Müller O.	17-Dec-97	Idle Speed	HMC_V6
Version: a 153589 from 18.12.97		657765.49.07	
File: CHAP_8.DOC	650H0000	Sourcefile:07800201.00D	Page 20 / 60

Calibration data:

Name	Dim	Hex. limits	Phys. limits	Resol.	Unit
IP_ISAPWM_TPS__N_32__TPS	7 x 5	0...FFH	-19,9...79,7	0,39	%
Basic idle - charge actuator opening versus operating point in Neutral or MT					
IP_ISAPWM_TPS_DRI__N_32__TPS	7 x 5	0...FFH	-19,9...79,7	0,39	%
Basic idle - charge actuator opening versus operating point in Drive					
IP_ISAPWM_TPS_CH__N_32__TPS	7 x 5	0...FFH	-50...49,93	0,39	%
Basic idle - charge actuator opening versus operating point if LV_IGA_CH = 1					
IP_ISAPWM_FAC_CH__TCO__T_AST	8 x 8	0...FFH	0...0,996	1 / 256	-
Factor for catalyst heating correction					

Proprietary data, company confidential. All rights reserved.
 Contitue a titre de secret d'entreprise. Tous droits réservés.
 Comunicado como segredo empresarial. Reservados todos os direitos.
 Confidado como secreto industrial. Nos reservamos todos los derechos.

Weitergabe sowie Vervielfältigung dieser Unterlage, Verwertung und Mitteilung ihres Inhalts nicht gestattet, soweit nicht ausdrücklich zugestanden. Zuwiderhandlungen verpflichten zu Schadensersatz. Alle Rechte vorbehalten, insbesondere für den Fall der Patenterteilung oder GM-Eintragung.

Editor: Müller O.	17-Dec-97	Idle Speed	HMC_V6
Version: a 153589 from 18.12.97		657765.49.07	
File: CHAP_8.DOC	650H0000	Sourcefile:07800201.00D	Page 21 / 60

1.3 Basic idle charge actuator opening versus engine load (ISAPWM_TCO_DRI_ACIN)

Output data:

Name	Mode	Hex. limits	Phys. limits	Resol.	Unit
ISAPWM_TCO_DRI_ACIN	V	00...FFFFH	0...99.998	1.526E-3	%
Basic idle - charge actuator opening versus engine load.					
ISAPWM_DRI_TRA	V	8000...7FFFH	-50...49.998	1.526E-3	%
Transient idle - charge actuator opening when LV_DRI_ISAPWM state changes.					

Input data:

LV_IS	TCO	LV_DRI_ISAPWM	LV_ACIN
NC_ISAPWM_N_MAX	N	TEMP_AT	MAF_FAC_ALTI_MMV
ISAPWM_LOAD_AT_FAC			

FUNCTION DESCRIPTION:

General information:

In order to take into account the engine load variations in Idle (LV_IS), four interpolated tables are used :

- IP_ISAPWM : for coolant temperature influence (no additional load).
- IP_ISAPWM_DRI : for coolant and A/T fluid temperatures and AT torque converter load influence with DRIVE engaged (LV_DRI_ISAPWM = 1).
- IP_ISAPWM_ACIN : for coolant temperature influence and air condition selected (LV_ACIN = ACIN).
- IP_ISAPWM_DRI_ACIN : for coolant and A/T fluid temperatures and AT torque converter load influence and air condition selected (LV_ACIN = ACIN) with DRIVE engaged (LV_DRI_ISAPWM = 1).

If $N < NC_ISAPWM_N_MAX$, the application recurrence is **10 msec**, otherwise **40 msec**.

The altitude influence is taken into consideration by the addition of IP_ISAPWM_ALTI.

A transient term ISAPWM_DRI_TRA is added when Drive is engaged and dis-engaged.

Application conditions:

Available for all engine operating states.

Proprietary data, company confidential. All rights reserved. Contient des données confidentielles de la société Siemens. Toute réimpression ou utilisation non autorisée sans la permission écrite de la société Siemens est formellement interdite. Reservados todos los derechos. No se permite la explotación económica ni la transformación de esta obra. Queda prohibida la difusión de esta obra. Reservados todos los derechos. No se permite la explotación económica ni la transformación de esta obra. Queda prohibida la difusión de esta obra.

Weitergabe sowie Vervielfältigung dieser Unterlage, Verwertung und Mitteilung ihres Inhalts ist gestattet, soweit nicht ausdrücklich zugestanden. Zuwiderhandlungen verpflichten zu Schadensersatz. Alle Rechte vorbehalten, insbesondere für den Fall der Patenterteilung oder GM-Entragung.

Editor: Müller O.	17-Dec-97	Idle Speed	HMC_V6
Version: a 153589 from 18.12.97		657765.49.07	
File: CHAP_8.DOC	650H0000	Sourcefile:07800301.00H	Page 22 / 60

Formula section:

1) Basic opening ISAPWM_TCO_DRI_ACIN

- **If** LV_DRI_ISAPWM = 0 MT or A/T not in DRIVE
and LV_ACIN = 0 air condition not selected
then ISAPWM_TCO_DRI_ACIN = IP_ISAPWM(_AT)_TCO +
IP_ISAPWM_ALTI_MAF_FAC_ALTI_MMV

- **If** LV_DRI_ISAPWM = 1 A/T in DRIVE
and LV_ACIN = 0 air condition not selected
then ISAPWM_TCO_DRI_ACIN = (IP_ISAPWM_DRI_TCO_TEMP_AT
+IP_ISAPWM_ALTI_MAF_FAC_ALTI_MMV)
* ISAPWM_LOAD_AT_FAC

- **If** LV_DRI_ISAPWM = 0 MT or A/T not in DRIVE
and LV_ACIN = 1 air condition selected
then ISAPWM_TCO_DRI_ACIN = IP_ISAPWM_ACIN(_AT)_TCO +
IP_ISAPWM_ALTI_MAF_FAC_ALTI_MMV

- **If** LV_DRI_ISAPWM = 1 A/T in DRIVE
and LV_ACIN = 1 air condition selected
then ISAPWM_TCO_DRI_ACIN = (IP_ISAPWM_DRI_ACIN_TCO_TEMP_AT
+ IP_ISAPWM_ALTI_MAF_FAC_ALTI_MMV)
* ISAPWM_LOAD_AT_FAC

- *Specific change limitations :*

a) Automatic Transmission (with or without air condition selected) :

a.1 - Switch **NEUTRAL** position to **DRIVE** position

To counteract the effect of the temperature, dependent on the converter, which locks the clutch when the DRIVE position is engaged, the idle - charge actuator opening is increased using the gradient limitation IP_ISAPWM_DRI_LGRD_INC_TCO.

a.2 - Switch **DRIVE** position to **NEUTRAL** position

When the transmission is shifted to NEUTRAL position, the idle - charge actuator opening is decreased using the gradient limitation IP_ISAPWM_DRI_LGRD_DEC_TCO.

Proprietary data, company confidential. All rights reserved.
 Contit a titre de secret d'entreprise. Tous droits réservés.
 Comunicado como segredo empresarial. Reservados todos os direitos.
 Confidado como secreto industrial. Nos reservamos todos los derechos.

Weitergabe sowie Vervielfältigung dieser Unterlage, Verwertung und Mitteilung ihres Inhalts nicht gestattet, soweit nicht ausdrücklich zugestanden. Zuwiderhandlungen verpflichten zu Schadensersatz. Alle Rechte vorbehalten, insbesondere für den Fall der Patenterteilung oder GM-Entragung.

Editor: Müller O.	17-Dec-97	Idle Speed	HMC_V6
Version: a 153589 from 18.12.97		657765.49.07	
File: CHAP_8.DOC	650H0000	Sourcefile:07800301.00H	Page 23 / 60

b) Air Condition :

b.1 - Air condition selected from **ON** (LV_ACIN = ACIN) to **OFF** (LV_ACIN = -)

As the engine speed does not increase in a single step when air condition is selected, the idle - charge actuator opening change using a gradient limitation C_ISAPWM_ACIN_LGRD_DEC_IS.

b.2 - Air condition selected from **OFF** (LV_ACIN = -) to **ON** (LV_ACIN = ACIN)

The idle - charge actuator opening is decreased using the gradient limitation C_ISAPWM_ACIN_LGRD_INC_IS.

The following drawing represents all the possible transitions :

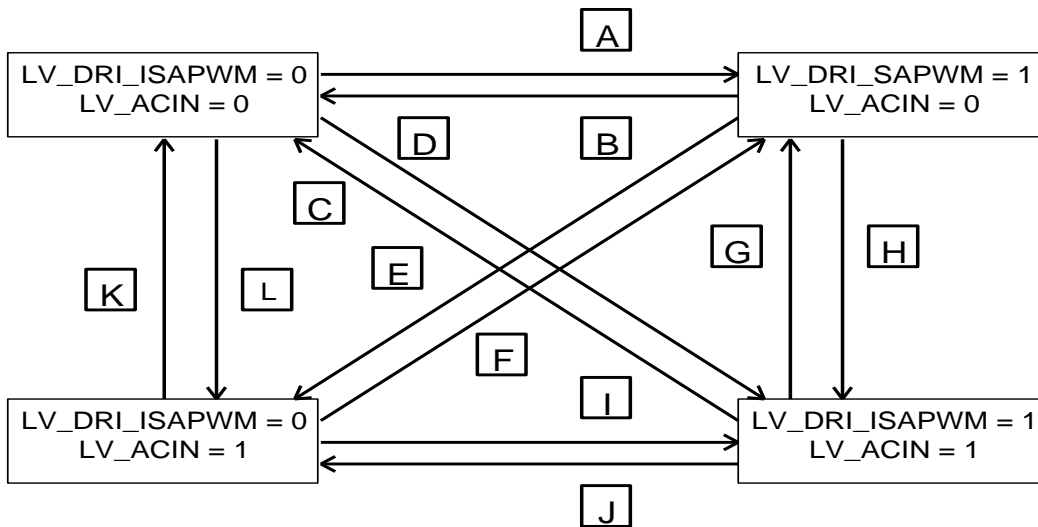

The following table resumes which gradient limitation is effective during the different transitions :

IP_ISAPWM_DRI_LGRD_INC_TCO	is written	DRI_INC
IP_ISAPWM_DRI_LGRD_DEC_TCO	is written	DRI_DEC
C_ISAPWM_ACIN_LGRD_DEC_IS	is written	ACIN_DEC
C_ISAPWM_ACIN_LGRD_INC_IS	is written	ACIN_INC

Proprietary data, company confidential. All rights reserved. Contine a titre de secret d'entreprise. Tous droits réservés. Comunicado como segredo empresarial. Reservados todos os direitos. Confidado como secreto industrial. Nos reservamos todos los derechos.

Weitergabe sowie Vervielfältigung dieser Unterlage, Verwertung und Mitteilung ihres Inhalts nicht gestattet, soweit nicht ausdrücklich zugestanden. Zuwiderhandlungen verpflichten zu Schadenersatz. Alle Rechte vorbehalten, insbesondere für den Fall der Patenterteilung oder GM-Entragung.

Editor: Müller O.	17-Dec-97	Idle Speed	HMC_V6
Version: a 153589 from 18.12.97		657765.49.07	
File: CHAP_8.DOC	650H0000	Sourcefile:07800301.00H	Page 24 / 60

Remark : (+) is a positive value and (-) is a negative value.

Transition	Actual ISAPWM < Target ISAPWM	Actual ISAPWM ≥ Target ISAPWM
A	+ DRI_INC	- DRI_INC
B	+ DRI_DEC	- DRI_DEC
C	+ DRI_DEC + ACIN_DEC	- DRI_DEC - ACIN_DEC
D	+ DRI_INC + ACIN_INC	- DRI_INC - ACIN_INC
E	+ ACIN_INC	- DRI_DEC
F	+ DRI_INC	- ACIN_DEC
G	+ ACIN_DEC	- ACIN_DEC
H	+ ACIN_INC	- ACIN_INC
I	+DRI_INC	- DRI_INC
J	+ DRI_DEC	- DRI_DEC
K	+ ACIN_DEC	- ACIN_DEC
L	+ ACIN_INC	- ACIN_INC

Proprietary data, company confidential. All rights reserved.
 Contine a titre de secret d'entreprise. Tous droits réservés.
 Comunicado como segredo empresarial. Reservados todos os direitos.
 Confidado como secreto industrial. Nos reservamos todos los derechos.

Weitergabe sowie Vervielfältigung dieser Unterlage, Verwertung und Mitteilung ihres Inhalts nicht gestattet, soweit nicht ausdrücklich zugestanden. Zuwiderhandlungen verpflichten zu Schadensersatz. Alle Rechte vorbehalten, insbesondere für den Fall der Patenterteilung oder GM-Entragung

2) Transient opening ISAPWM_DRI_TRA

If LV_DRI_ISAPWM = 0

then

ISAPWM_DRI_TRA is set to 0 without change limitation

else

If Transition LV_DRI_ISAPWM = 0 -> 1

then

if LV_ACIN = 0

then

ISAPWM_DRI_TRA is set to IP_ISAPWM_DRI_TRA_1_TCO with change limitation C_ISAPWM_DRI_INC_TRA and reseted to 0 with change limitation C_ISAPWM_DRI_DEC_TRA

else (LV_ACIN = 1)

ISAPWM_DRI_TRA is set to IP_ISAPWM_DRI_TRA_2_TCO with change limitation C_ISAPWM_DRI_INC_TRA and reseted to 0 with change limitation C_ISAPWM_DRI_DEC_TRA

else

ISAPWM_DRI_TRA = 0

Editor: Müller O.	17-Dec-97	Idle Speed	HMC_V6
Version: a 153589 from 18.12.97		657765.49.07	
File: CHAP_8.DOC	650H0000	Sourcefile:07800301.00H	Page 25 / 60

Calibration data:

Name	Dim	Hex. limits	Phys. limits	Resol.	Unit
IP_ISAPWM(_AT)__TCO	6	00...FFH	0...99.609	0.3891	%
Basic idle - charge opening with MT or AT in NEUTRAL.					
IP_ISAPWM_DRI__TCO__TEMP_AT	6 * 4	0...FFH	0...99.61	0.39	%
Basic idle - charge opening with AT in DRIVE or REVERSE.					
IP_ISAPWM_ACIN(_AT)__TCO	6	0...FFH	0...99.61	0.39	%
Basic idle - charge opening with MT or AT in NEUTRAL and air condition is selected.					
IP_ISAPWM_DRI_ACIN__TCO__TEMP_AT	6 * 4	0...FFH	0...99.61	0.39	%
Basic idle - charge opening with AT in DRIVE or REVERSE and air condition is selected.					
IP_ISAPWM_ALTI__MAF_FAC_ALTI_MMV	6	0...FFH	0...99.61	0.39	%
Basic idle - charge opening correction for altitude influence.					
IP_ISAPWM_DRI_LGRD_INC__TCO	6	01...FFH	0.098...24.902	0.098	%
Idle charge - actuator opening increase gradient limitation with DRIVE or REVERSE engaged.					
IP_ISAPWM_DRI_LGRD_DEC__TCO	6	01...FFH	0.098...24.902	0.098	%
Idle charge - actuator opening decrease gradient limitation with DRIVE or REVERSE engaged.					
C_ISAPWM_ACIN_LGRD_DEC_IS	1	01...FFH	0.098...24.902	0.098	%
Idle charge - actuator opening gradient limitation when air condition is switched Off.					
C_ISAPWM_ACIN_LGRD_INC_IS	1	01...FFH	0.098...24.902	0.098	%
Idle charge - actuator opening gradient limitation when air condition is switched On.					
IP_ISAPWM_DRI_TRA_1__TCO	6	00...FFH	0...49.8	0.195	%
ISAPWM_DRI_TRA set value when Drive is engaged with LV_ACIN = 0					
IP_ISAPWM_DRI_TRA_2__TCO	6	00...FFH	0...49.8	0.195	%
ISAPWM_DRI_TRA set value when Drive is engaged with LV_ACIN = 1					
C_ISAPWM_DRI_INC_TRA	1	01...FFH	0.0244...6.225	0.0244	%
ISAPWM_DRI_TRA increase change limitation					
C_ISAPWM_DRI_DEC_TRA	1	01...FFH	0.0244...6.225	0.0244	%
ISAPWM_DRI_TRA reset change limitation					

Proprietary data, company confidential. All rights reserved.
 Contient des informations confidentielles. Tous droits réservés.
 Comunicado como segredo empresarial. Reservados todos os direitos.
 Confidado como secreto industrial. Nos reservamos todos los derechos.

Weitergabe sowie Vervielfältigung dieser Unterlage, Verwertung und Mitteilung ihres Inhalts ist gestattet, soweit nicht ausdrücklich zugestanden. Zuwiderhandlungen verpflichten zu Schadensersatz. Alle Rechte vorbehalten, insbesondere für den Fall der Patenterteilung oder GM-Entragung.

Editor: Müller O.	17-Dec-97	Idle Speed	HMC_V6
Version: a 153589 from 18.12.97		657765.49.07	
File: CHAP_8.DOC	650H0000	Sourcefile:07800301.00H	Page 26 / 60

1.4 Idle charge actuator opening with air condition compressor
(ISAPWM_ACCIN, ISAPWM_TRA_ACCIN)

Output data:

Name	Mode	Hex. limits	Phys. limits	Resol.	Unit
ISAPWM_ACCIN	V	00...FFFFH	0...99,998	1,526E-3	%
Idle - charge actuator opening correction with air condition compressor.					
ISAPWM_TRA_ACCIN	V	8000...7FFFH	-50...49,998	1,526E-3	%
Idle - charge actuator opening correction with air condition compressor instationary.					

Input data:

TIA	N_32	LV_ACCIN	LV_RLY_ACCOUT_CTRL
N_SP_IS	N	MAF_ALTI_COR	ISAPWM_ACCIN_AD_MMV_IS
NC_ISAPWM_N_MAX	LV_PRS_ACC	LV_DRI_ISAPWM	MAF_FAC_ALTI_MMV

FUNCTION DESCRIPTION:

General information:

The increased duty cycle for the air condition compressor ISAPWM_ACCIN must cover the compressor's power requirements depending on the engine speed, the intake air temperature, the pressure level in the A/C circuit and the mass air flow corrected by the altitude.

To ensure rapid intake pipe filling and to accelerate the air condition compressor initially from its position OFF, an additional duty cycle ISAPWM_TRA_ACCIN is used.

If $N < NC_ISAPWM_N_MAX$ the application recurrence is **10 msec**, otherwise **40 msec**.

Proprietary data, company confidential. All rights reserved.
 Contient des informations confidentielles. Tous droits réservés.
 Comunicado como segredo empresarial. Reservados todos os direitos.
 Confidado como secreto industrial. Nos reservamos todos los derechos.

Weitergabe sowie Vervielfältigung dieser Unterlage, Verwertung und Mitteilung ihres Inhalts ist gestattet, soweit nicht ausdrücklich zugestanden. Zuwiderhandlungen verpflichten zu Schadensersatz. Alle Rechte vorbehalten, insbesondere für den Fall der Patenterteilung oder GM-Entragung.

Editor: Müller O.	17-Dec-97	Idle Speed	HMC_V6
Version: a 153589 from 18.12.97		657765.49.07	
File: CHAP_8.DOC	650H0000	Sourcefile:07800401.00H	Page 27 / 60

Description:

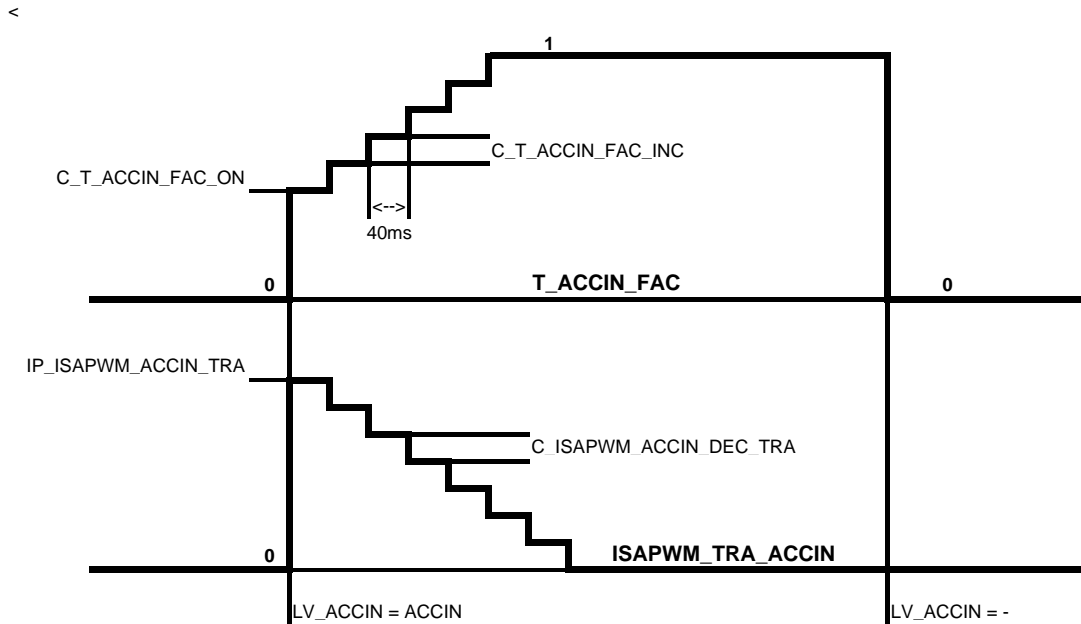

a) - **ISAPWM_ACCIN** calculation :

The basic pre-control is the sum resulting from the addition of IP_ISAPWM_ACCIN_TIA_LV_PRS_ACC, the idle speed adaptation ISAPWM_ACCIN_AD_MMV_IS with air-condition compressor and IP_ISAPWM_DRI_ACCIN_ALTI_MAF_FAC_ALTI_MMV.

If the air - condition compressor is enabled or disabled, the resulting value is taken over without limitation gradient.

If LV_PRS_ACC value changes, the new IP_ISAPWM_ACCIN value is applied with the change limitation C_ISAPWM_ACCIN_LGRD.

This basic pre - control is weighted by multiplication of two values :

1 - IP_ISAPWM_ACCIN_N_MAF_Nxx_MAF_ALTI_COR

This index table includes the inter-relationship between the engine speed (power consumption) and the mass air flow corrected to sea-level (differential pressure at idle - charge actuator).

Remark :

In order not to disturb the idle speed stabilization in the engine operating state idle (LV_IS), the nominal idle speed **N_SP_IS** is taken into account as set point (**Nxx**) for this interpolated table; else (out of idle) **N**.

Proprietary data, company confidential. All rights reserved. Contient des informations confidentielles. Tous droits réservés. Comunicado como segredo empresarial. Reservados todos os direitos. Confidado como secreto industrial. Nos reservamos todos los derechos.

Weitergabe sowie Vervielfältigung dieser Unterlage, Verwertung und Mitteilung ihres Inhalts nicht gestattet, soweit nicht ausdrücklich zugestanden. Zuwiderhandlungen verpflichten zu Schadenersatz. Alle Rechte vorbehalten, insbesondere für den Fall der Patenterteilung oder GM-Entragung.

Editor: Müller O.	17-Dec-97	Idle Speed	HMC_V6
Version: a 153589 from 18.12.97		657765.49.07	
File: CHAP_8.DOC	650H0000	Sourcefile:07800401.00H	Page 28 / 60

2 - T_ACCIN_FAC

It is used for emulating the slow load build - up after the air - condition compressor has been enabled.

It is calculated as follows :

- * with air condition compressor **OFF** : T_ACCIN_FAC is set to **0**.
(LV_RLY_ACCOUT_CTRL = 0)
- * with air condition compressor **ON** : T_ACCIN_FAC is set to C_T_ACCIN_FAC_ON and afterwards T_ACCIN_FAC is incremented by the value C_T_ACCIN_FAC_INC at intervals of **40 msec**, until the value **1** has been reached.

Formula section:

- * With air condition compressor **OFF** (LV_RLY_ACCOUT_CTRL = 0) :

$$ISAPWM_ACCIN = 0$$

- * With air condition compressor **ON** (LV_RLY_ACCOUT_CTRL = 1) :

$$ISAPWM_ACCIN = (IP_ISAPWM_ACCIN_TIA_LV_PRS_ACC + ISAPWM_ACCIN_AD_MMV_IS)$$

- * IP_ISAPWM_ACCIN_N_MAF_Nxx_MAF_ALTI_COR
- * T_ACCIN_FAC

- * With air condition compressor **ON** (LV_RLY_ACCOUT_CTRL = 1) and **DRIVE** engaged (LV_DRI_ISAPWM = 1) :

$$ISAPWM_ACCIN = (IP_ISAPWM_ACCIN_TIA_LV_PRS_ACC + ISAPWM_ACCIN_AD_MMV_IS + IP_ISAPWM_DRI_ACCIN_ALTI_MAF_FAC_ALTI_MMV)$$

- * IP_ISAPWM_ACCIN_N_MAF_Nxx_MAF_ALTI_COR
- * T_ACCIN_FAC

Remark :

ISAPWM_ACCIN_AD_MMV_IS is the idle speed adaptation with air condition compressor.

The nominal idle speed N_SP_IS is taken into account as set point (Nxx) for these interpolated tables in idle (LV_IS); else (out of idle) N.

Proprietary data, company confidential. All rights reserved. Contine a titre de secret d'entreprise. Tous droits réservés. Comunicado como segredo empresarial. Reservados todos os direitos. Confidado como secreto industrial. Nos reservamos todos los derechos.

Weitergabe sowie Vervielfältigung dieser Unterlage, Verwertung und Mitteilung ihres Inhalts nicht gestattet, soweit nicht ausdrücklich zugestanden. Zuwiderhandlungen verpflichten zu Schadensersatz. Alle Rechte vorbehalten, insbesondere für den Fall der Patenterteilung oder GM-Entragung.

Editor:	Müller O.	17-Dec-97	Idle Speed	HMC_V6
Version:	a 153589 from 18.12.97		657765.49.07	
File:	CHAP_8.DOC	650H0000	Sourcefile:07800401.00H	Page 29 / 60

b) - ISAPWM_TRA_ACCIN calculation :

ISAPWM_TRA_ACCIN is set to IP_ISAPWM_ACCIN_TRA_Nxx when air condition compressor is enabled and reset to zero using the change limitation C_ISAPWM_ACCIN_DEC_TRA.

Calibration data:

Name	Dim	Hex. limits	Phys. limits	Resol.	Unit
IP_ISAPWM_ACCIN_TIA_LV_PRS_ACC	4 * 2	0...FFH	0...99,61	0,39	%
Idle - charge actuator opening corr. with A/C compressor versus intake air temperature and A/C pressure level					
IP_ISAPWM_DRI_ACCIN_ALTI_MAF_FAC_ALTI_MMV	6	0...FFH	0...99,61	0,39	%
Idle - charge actuator opening corr. with A/C compressor and DRIVE versus altitude correction factor.					
IP_ISAPWM_ACCIN_N_MAF__N_MAF_ALTI_COR	4 * 4	0...FFH	0...15,94	0,0625	-
Idle - charge actuator opening correction with air condition compressor versus operating point.					
C_ISAPWM_ACCIN_LGRD	1	01...FFH	0,024...6,226	0,0244	%
IP_ISAPWM_ACCIN change limitation.					
C_T_ACCIN_FAC_ON	1	00...FFH	0...0,997	3,895E-3	-
T_ACCIN_FAC first set value.					
C_T_ACCIN_FAC_INC	1	01...FFH	0,00024...0,0622	0,00024	-
T_ACCIN_FAC increase value.					
IP_ISAPWM_ACCIN_TRA_N	4	0...FFH	-50...49,6	0,39	%
ISAPWM_TRA_ACCIN set value when air condition compressor is enabled out of idle.					
IP_ISAPWM_ACCIN_TRA_N_SP_IS	4	0...FFH	-50...49,6	0,39	%
ISAPWM_TRA_ACCIN set value when air condition compressor is enabled in idle.					
C_ISAPWM_ACCIN_DEC_TRA	1	01...FFH	0,0244...6,225	0,0244	%
ISAPWM_TRA_ACCIN reset change limitation.					

Proprietary data, company confidential. All rights reserved. Contine a titre de secret d'entreprise. Tous droits réservés. Comunicado como segredo empresarial. Reservados todos os direitos. Confidado como secreto industrial. Nos reservamos todos los derechos.

Weitergabe sowie Vervielfältigung dieser Unterlage, Verbreitung und Mitteilung ihres Inhalts nicht gestattet, soweit nicht ausdrücklich zugestanden. Zuwiderhandlungen verpflichten zu Schadenersatz. Alle Rechte vorbehalten, insbesondere für den Fall der Patenterteilung oder GM-Entragung.

Editor: Müller O.	17-Dec-97	Idle Speed	HMC_V6
Version: a 153589 from 18.12.97		657765.49.07	
File: CHAP_8.DOC	650H0000	Sourcefile:07800401.00H	Page 30 / 60

1.5 Basic idle charge actuator opening corr. with catalyst heating (ISAPWM_CH)

Output data:

Name	Mode	Hex. limits	Phys. limits	Resol.	Unit
ISAPWM_CH	V	00...FFFFH	0...99,998	1,526E-3	%
Basic idle - charge actuator opening correction with catalyst heating function					
ISAPWM_IGA_CH	V	0...FFFFH	0...99,9985	0,0015	%
Basic idle - charge actuator opening correction related to ignition angle decrease					
ISAPWM_N_SP_ADD_CH	V	0...FFFFH	0...99,9985	0,0015	%
Basic idle - charge actuator opening correction related to nominal idle speed increase					

Input data:

LV_IGA_CH	LV_N_SP_ADD_CH	LV_IS	N_SP_ADD_CH
LV_DRI	TCO	IGA_CH	DRI_N_SP_ADD_CH

FUNCTION DESCRIPTION:

General information:

The catalyst heating function can influence:

- basic IGA in Idle
- nominal idle speed N_SP_IS

To take into account this corrections, a catalyst heating term ISAPWM_CH is added to the basic idle speed charge actuator opening.

ISAPWM_CH is the sum of two terms:

- ISAPWM_IGA_CH is related to IGA
- ISAPWM_N_SP_ADD_CH is related to N_SP_IS

Formula section:

* ISAPWM_IGA_CH:

```

if      LV_IGA_CH = 1 and LV_IS = 1
then   ISAPWM_IGA_CH = IP_ISAPWM_IGA__TCO__IGA_CH
else   ISAPWM_IGA_CH = 0
    
```

Proprietary data, company confidential. All rights reserved. Contient des informations confidentielles. Tous droits réservés. Comunicado como secreto empresarial. Reservados todos los derechos. Confidado como secreto industrial. Nos reservamos todos los derechos.

Weitergabe sowie Vervielfältigung dieser Unterlage, Verwertung und Mitteilung ihres Inhalts nicht gestattet, soweit nicht ausdrücklich zugestanden. Zuwiderhandlungen verpflichten zu Schadenersatz. Alle Rechte vorbehalten, insbesondere für den Fall der Patenterteilung oder GM-Enttragung.

Editor: Müller O.	17-Dec-97	Idle Speed	HMC_V6
Version: a 153589 from 18.12.97		657765.49.07	
File: CHAP_8.DOC	650H0000	Sourcefile:07800F01.00D	Page 31 / 60

Proprietary data, company confidential. All rights reserved. Contine a titre de secret d'entreprise. Tous droits réservés. Comunicado como segredo empresarial. Reservados todos os direitos. Confidado como secreto industrial. Nos reservamos todos los derechos.

Weitergabe sowie Vervielfältigung dieser Unterlage, Verwertung und Mitteilung ihres Inhalts nicht gestattet, soweit nicht ausdrücklich zugestanden. Zuwiderhandlungen verpflichten zu Schadenersatz. Alle Rechte vorbehalten, insbesondere für den Fall der Patenterteilung oder GM-Enttragung

** ISAPWM_N_SP_ADD_CH:*

```

If      LV_N_SP_ADD_CH = 1 and LV_IS = 1
then
    If MT or AT in Drive (LV_DRI = 0):
    then ISAPWM_N_SP_ADD_CH = IP_ISAPWM_N__TCO__N_SP_ADD_CH

    If AT in Drive (LV_DRI = 1):
    then ISAPWM_N_SP_ADD_CH =
        IP_ISAPWM_DRI_N__TCO__DRI_N_SP_ADD_CH

    else  ISAPWM_N_SP_ADD_CH = 0
    
```

** ISAPWM_CH:*

ISPAWM_CH = ISAPWM_IGA_CH + ISAPWM_N_SP_ADD_CH

The change limitation C_ISAPWM_LGRD_CH is always applied to ISAPWM_CH.

Calibration data:

Name	Dim	Hex. limits	Phys. limits	Resol.	Unit
IP_ISAPWM_IGA__TCO__IGA_CH	8 * 8	0...FFH	0...99,61	0,39	%
Basic idle charge actuator correction with catalyst heating function (related to IGA)					
IP_ISAPWM_N__TCO__N_SP_ADD_CH	8 * 6	0...FFH	0...99,61	0,39	%
Basic idle charge actuator correction with catalyst heating function (related to N_SP_ADD_CH)					
IP_ISAPWM_DRI_N__TCO__DRI_N_SP_ADD_CH	8 * 6	0...FFH	0...99,61	0,39	%
Basic idle charge actuator correction with catalyst heating function (related to N_SP_ADD_CH)					
C_ISAPWM_LGRD_CH	1	01...FFH	0,0977...24,902	0,098	%
Gradient limitation for ISAPWM_CH					

Editor: Müller O.	17-Dec-97	Idle Speed	HMC_V6
Version: a 153589 from 18.12.97		657765.49.07	
File: CHAP_8.DOC	650H0000	Sourcefile:07800F01.00D	Page 32 / 60

1.6 Dashpot function (ISAPWM_DHP)

Output data:

Name	Mode	Hex. limits	Phys. limits	Resol.	Unit
ISAPWM_DHP	V	00...FFFFH	0...99,998	1,526E-3	%
Dashpot correction.					

Input data:

ISAPWM	N_32	TPS	
--------	------	-----	--

FUNCTION DESCRIPTION:

General information:

In order to improve driveability on trailing throttle, the desired torque reduction is slower than this is allowed by the actual closing speed of the throttle.

An additive value on ISAPWM is set by the IP_ISAPWM_DHP(_AT)__N_32__TPS value.

The deceleration of the torque reduction is achieved by the gradient limitation IP_ISAPWM_LGRD__N_32 which acts in the closing direction for IP_ISAPWM_DHP(_AT)__N_32__TPS.

The gradient limitation depends on the engine speed.

In the opening direction of the idle - charge actuator, new values derived from IP_ISAPWM_DHP(_AT)__N_32__TPS are integrated without gradient limitation.

The application recurrency is **40 msec**.

Application conditions:

Dashpot function is available for all engine operating states.

Formula section:

If ISAPWM_DHP_(n) ≥ ISAPWM_DHP_(n-1)
then ISAPWM_DHP = IP_ISAPWM_DHP(_AT)__N_32__TPS
else ISAPWM_DHP is decreased with the IP_ISAPWM_LGRD__N_32 gradient limitation.

Proprietary data, company confidential. All rights reserved. Contient a titre de secret d'entreprise. Tous droits réservés. Comunicado como segredo empresarial. Reservados todos os direitos. Confidado como secreto industrial. Nos reservamos todos los derechos.

Weitergabe sowie Vervielfältigung dieser Unterlage, Verwertung und Mitteilung ihres Inhalts nicht gestattet, soweit nicht ausdrücklich zugestanden. Zuwiderhandlungen verpflichten zu Schadensersatz. Alle Rechte vorbehalten, insbesondere für den Fall der Patenterteilung oder GM-Entragung.

Editor: Müller O.	17-Dec-97	Idle Speed	HMC_V6
Version: a 153589 from 18.12.97		657765.49.07	
File: CHAP_8.DOC	650H0000	Sourcefile:07800501.00E	Page 33 / 60

Calibration data:

Name	Dim	Hex. limits	Phys. limits	Resol.	Unit
IP_ISAPWM_DHP(_AT)__N_32__TPS	7 x 5	0...FFH	0...99,61	0,39	%
Basic ISAPWM value for dashpot..					
IP_ISAPWM_LGRD__N_32	5	01...FFH	0,098...24,902	0,098	%
ISAPWM gradient limitation for ISAPWM_DHP in the closing direction.					

Proprietary data, company confidential. All rights reserved.
 Contitue a titre de secret d'entreprise. Tous droits réservés.
 Comunicado como segredo empresarial. Reservados todos os direitos.
 Confidado como secreto industrial. Nos reservamos todos los derechos.

Weitergabe sowie Vervielfältigung dieser Unterlage, Verwertung und Mitteilung ihres Inhalts nicht gestattet, soweit nicht ausdrücklich zugestanden. Zuwiderhandlungen verpflichten zu Schadensersatz. Alle Rechte vorbehalten, insbesondere für den Fall der Patenterteilung oder GM-Entragung.

Editor: Müller O.	17-Dec-97	Idle Speed	HMC_V6
Version: a 153589 from 18.12.97		657765.49.07	
File: CHAP_8.DOC	650H0000	Sourcefile:07800501.00E	Page 34 / 60

1.7 Idle speed regulation correction (ISAPWM_IS)

Output data:

Name	Mode	Hex. limits	Phys. limits	Resol.	Unit
ISAPWM_IS	V	8000...7FFFH	-50...49,998	1,526E-3	%
Global idle speed regulation					
ISAPWM_P_IS	V	80...7FH	-50...49,9985	0,39	%
Proportional idle speed regulation term.					
ISAPWM_I_IS	V	8000...7FFFH	-50...49,998	1,526E-3	%
Integral idle speed regulation term.					
ISAPWM_D_IS	V	8000...7FFFH	-50...49,998	1,526E-3	%
Derivative idle speed regulation term.					
LV_ISAPWM_IS_ACT	V	0...01H	0...1	1	-
Boolean for idle speed regulation ISAPWM_IS active (passive / active).					

Input data:

N	NC_ISAPWM_N_MAX	ISAPWM	LV_IS
LV_ST	N_DIF_COR	N_GRD	TCO
LV_ES	ISAPWM_AD_COR_IS	N_SP_IS	MAF_FAC_ALTI_MMV

FUNCTION DESCRIPTION:

General information:

At idle (LV_IS), a PID controller is superimposed on the ISAPWM idle pre - control to compensate deviations from the nominal engine speed.

The **I** controller can be adjusted to react more quickly or slowly to the approach and deviation from the nominal engine speed.

The **D** component additionally takes effect in case of very large negative engine speed gradients.

If the conditions for PID are triggered, the **P** and **I** components are calculated. For **D** component calculation, there are specific conditions.

In idle, once the idle speed regulation is triggered, ISAPWM_IS is calculated including P, I and D-components. If idle speed regulation is not triggered, ISAPWM_IS is calculated only with the I-component.

If $N < NC_ISAPWM_N_MAX$, the application recurrence is **10 msec**, otherwise **40 msec**.

Proprietary data, company confidential. All rights reserved. Contine a titre de secret d'entreprise. Tous droits réservés. Comunicado como segredo empresarial. Reservados todos os direitos. Confidado como secreto industrial. Nos reservamos todos los derechos.

Weitergabe sowie Vervielfältigung dieser Unterlage, Verwertung und Mitteilung ihres Inhalts nicht gestattet, soweit nicht ausdrücklich zugestanden. Zuwiderhandlungen verpflichten zu Schadensersatz. Alle Rechte vorbehalten, insbesondere für den Fall der Patenterteilung oder GM-Entragung.

Editor: Müller O.	17-Dec-97	Idle Speed	HMC_V6
Version: a 153589 from 18.12.97		657765.49.07	
File: CHAP_8.DOC	650H0000	Sourcefile:07800601.00H	Page 35 / 60

Application conditions:

1 - Activation conditions :

* The idle speed regulation is switched on at idle (LV_IS) after the transition from start (LV_ST), if one of the following conditions is met :

- a) $N_DIF_COR \geq 0$ **and** $N_GRD \leq 0$
 or
- b) $N_DIF_COR < 0$
 and

in case of an engine speed increase by more than C_ISAPWM_N_ADD_ON, after an engine speed decrease during at least two consecutive segments (**240 °CRK**).

* The idle speed regulation is switched on at idle (LV_IS) after transition from the remaining engine operating states if one of the following conditions is met :

- a) $N_DIF_COR \geq 0$
 or
- b) $N_DIF_COR < 0$ **and** “Stable Engine Speed” is detected.

“Stable Engine Speed” description :

The engine speed is stored (N_{stored}) upon entry in idle, and a timer C_T_MIN_RIS is started. When the timer has elapsed, the engine speed is compared to the stored speed.

if $N \geq N_{stored} - C_N_DIF_MIN_IS$
then the idle speed regulation is switched on
else the process is repeated until the idle speed regulation is enabled or the state idle is exited.

When these conditions are performed then **LV_ISAPWM_IS_ACT** is set to **1 (Active)**.

2 - Deactivation condition :

The idle speed regulation is switched off if LV_IS is exited. Then **LV_ISAPWM_IS_ACT** is set to **0 (Passive)**.

Editor: Müller O.	17-Dec-97	Idle Speed	HMC_V6
Version: a 153589 from 18.12.97		657765.49.07	
File: CHAP_8.DOC	650H0000	Sourcefile:07800601.00H	Page 36 / 60

Proprietary data, company confidential. All rights reserved. Contine a titre de secret d'entreprise. Tous droits réservés. Comunicado como secreto empresarial. Reservados todos os direitos. Confidado como secreto industrial. Nos reservamos todos los derechos.

Weitergabe sowie Vervielfältigung dieser Unterlage, Verwertung und Mitteilung ihres Inhalts nicht gestattet, soweit nicht ausdrücklich zugestanden. Zuwiderhandlungen verpflichten zu Schadenersatz. Alle Rechte vorbehalten, insbesondere für den Fall der Patenterteilung oder GM-Enttragung

Formula section:

1 - Initialization :

At engine stopped (LV_ES) or start (LV_ST) :

$$\begin{aligned}
 \text{ISAPWM_I_IS} &= \text{IP_ISAPWM_INI_I_ST_TCO_MAF_FAC_ALTI_MMV} \\
 \text{ISAPWM_P_IS} &= 0 \\
 \text{ISAPWM_D_IS} &= 0 \\
 \text{ISAPWM_AD_COR_IS} &= \text{ISAPWM_I_IS}
 \end{aligned}$$

2 - ISAPWM_IS calculation :

$$\begin{aligned}
 \text{ISAPWM_IS} &= (\text{ISAPWM_P_IS} + \text{ISAPWM_I_IS} + \text{ISAPWM_D_IS}) \\
 &\quad * \text{IP_ISAPWM_TCO_FAC_IS_TCO}
 \end{aligned}$$

with : IP_ISAPWM_TCO_FAC_IS_TCO idle controller temperature weighting

and :

- a) ISAPWM_P_IS = IP_ISAPWM_P_IS__N_DIF_COR
(proportional component)
- b) **if** $|N_DIF_{(n)}| - |N_DIF_{(n-3)}| < 0$
then $\text{ISAPWM_I_IS}_{(n)} = \text{ISAPWM_I_IS}_{(n-1)} + \text{IP_ISAPWM_POS_I_IS_N_DIF_COR}$
 (integral component towards nominal idle speed N_SP_IS)
else $\text{ISAPWM_I_IS}_{(n)} = \text{ISAPWM_I_IS}_{(n-1)} + \text{IP_ISAPWM_NEG_I_IS_N_DIF_COR}$
 (integral component away from nominal idle speed N_SP_IS)

Remark : The I component is computed every **40 msec.**, independently of engine speed.

- c) ISAPWM_D_IS = IP_ISAPWM_D_IS__N_GRD
(derivative component)

Editor: Müller O.	17-Dec-97	Idle Speed	HMC_V6
Version: a 153589 from 18.12.97		657765.49.07	
File: CHAP_8.DOC	650H0000	Sourcefile:07800601.00H	Page 37 / 60

Calibration data:

Name	Dim	Hex. limits	Phys. limits	Resol.	Unit
C_ISAPWM_N_ADD_ON	1	0...1FE0H	0...8160	1	rpm
Minimum engine speed increase for idle controller after start.					
C_T_MIN_RIS	1	0...FFFFH	0,01...655,35	0,01	sec
Engine speed variation check period if N_DIF_COR < 0.					
C_N_DIF_MIN_IS	1	0...1FE0H	0...8160	1	rpm
Maximum engine speed decrease to stop idle speed regulation					
IP_ISAPWM_P_IS__N_DIF_COR	12	00...FFH	-50...49,609	0,3891	%
P component of idle controller.					
IP_ISAPWM_POS_I_IS__N_DIF_COR	8	00...FFFFH	-50...49,998	1,526E-3	%
I component of idle controller towards N_SP_IS.					
IP_ISAPWM_NEG_I_IS__N_DIF_COR	8	00...FFFFH	-50...49,998	1,526E-3	%
I component of idle controller away from N_SP_IS.					
IP_ISAPWM_D_IS__N_GRD	4	00...FFH	-50...49,609	0,3891	%
D component of idle controller.					
IP_ISAPWM_TCO_FAC_IS__TCO	4	00...FFH	0...1,922	7,509E-3	-
Idle controller temperature weighting.					
IP_ISAPWM_INI_I_ST__TCO__MAF_FAC_A LTI_MMV	6 x 4	00...FFFFH	-50...49,609	0,3891	%
Initialisation value at start for I component of idle controller.					

Proprietary data, company confidential. All rights reserved.
 Contient des informations confidentielles. Tous droits réservés.
 Comunicado como segredo empresarial. Reservados todos os direitos.
 Confidado como secreto industrial. Nos reservamos todos los derechos.

Weitergabe sowie Vervielfältigung dieser Unterlage, Verwertung und Mitteilung ihres Inhalts ist gestattet, soweit nicht ausdrücklich zugestanden. Zuwiderhandlungen verpflichten zu Schadensersatz. Alle Rechte vorbehalten, insbesondere für den Fall der Patenterteilung oder GM-Entragung.

Editor: Müller O.	17-Dec-97	Idle Speed	HMC_V6
Version: a 153589 from 18.12.97		657765.49.07	
File: CHAP_8.DOC	650H0000	Sourcefile:07800601.00H	Page 38 / 60

1.7.1 Idle speed regulation limits

Input data:

LV_IS	VS	ISAPWM_I_IS	LV_ACIN
LV_INF	LV_ST	ISAPWM_AD_COR_IS	ISAPWM
LV_CT	N_32	C_N_MAX_INF	N_GRD
LV_PU	ISAPWM_D_IS	ISAPWM_P_IS	C_T_MIN_D_ISA

1.7.1.1 I component limits

General information:

The application recurrence is **40 msec**.

* *In idle (LV_IS) :*

- a) **If** VS = 0
or (VS ≠ 0 and C_T_MAX_IS not elapsed)
then C_ISAPWM_MIN_I_IS < **ISAPWM_I_IS** < C_ISAPWM_MAX_I_IS

- b) **If** VS ≠ 0
and (C_T_MAX_IS elapsed **or** transition to idle (LV_IS))
and air condition not selected (LV_ACIN = -)
then C_ISAPWM_VS_MIN_I_IS < **ISAPWM_I_IS** < C_ISAPWM_VS_MAX_I_IS

- c) **If** VS ≠ 0
and (C_T_MAX_IS elapsed **or** transition to idle (LV_IS))
and air condition selected (LV_ACIN = ACIN)
then C_ISAPWM_VS_ACCIN_MIN_I_IS < **ISAPWM_I_IS** < C_ISAPWM_VS_ACCIN_MAX_I_IS

Remark :

- The duration C_T_MAX_IS is only used when there is a transition from VS = 0 to VS ≠ 0 in idle.
- No gradient limitation on I - component is applied in idle (LV_IS).

- In the closing direction, if ISAPWM reached 0% then ISAPWM_I_IS remains unchanged.
- In the opening direction, if ISAPWM reached 100% then ISAPWM_I_IS remains unchanged.

Proprietary data, company confidential. All rights reserved. Contient a titre de secret d'entreprise. Tous droits réservés. Comunicado como segredo empresarial. Reservados todos os direitos. Confidado como secreto industrial. Nos reservamos todos los derechos.

Weitergabe sowie Vervielfältigung dieser Unterlage, Verbreitung und Mitteilung ihres Inhalts nicht gestattet, soweit nicht ausdrücklich zugestanden. Zuwiderhandlungen verpflichten zu Schadensersatz. Alle Rechte vorbehalten, insbesondere für den Fall der Patenterteilung oder GM-Enttragung.

Editor: Müller O.	17-Dec-97	Idle Speed	HMC_V6
Version: a 153589 from 18.12.97		657765.49.07	
File: CHAP_8.DOC	650H0000	Sourcefile:07800601.00H	Page 39 / 60

* *Out of idle* :

If engine operating state start (LV_ST) is not active
and the conditions for ISAPWM_I_IS when rapid engine speed drop are not met
then the I controller is controlled to ISAPWM_AD_COR_IS using the gradient limitation C_ISAPWM_LGRD.

“*Engine speed drop*” description :

This function can be activated in and out of idle.

If LV_CT = 1
and N_32 < C_N_MAX_INF
and N_GRD < C_ISAPWM_N_GRD_I_ADD
then ISAPWM_I_IS_(n) = ISAPWM_I_IS_(n-1) + C_ISAPWM_I_ADD

In this case, ISAPWM_I_IS is not limited.

* *Exit from idle* :

ISAPWM_I_IS_(n) = ISAPWM_I_IS_(n-1) + ISAPWM_D_IS_(n-1) + ISAPWM_P_IS_(n-1)
 ISAPWM_D_IS_(n) = 0
 ISAPWM_P_IS_(n) = 0

1.7.1.2 D component limits

(refer to “ Intercept Function “ in the major chapter “ Engine Operating States ”)

A D component becomes effective to support the idle speed regulation in case of a large negative engine speed gradient.

This D component, which can be applied in idle (LV_IS) or in trailing throttle (LV_PU), takes effect below an engine speed threshold, in order to facilitate an engine intercept without drop below the nominal idle speed.

Activation conditions :

Intercept function active (LV_INF = INF).

Deactivation conditions :

Intercept function not active (LV_INF = -) and the timer C_T_MIN_D_ISA has elapsed.

If one of the disabled conditions are met, the D component is reset to 0 using C_ISAPWM_LGRD_Dchange limitation.

In idle (LV_IS) the D - component is activated only once.

Editor:	Müller O.	17-Dec-97	Idle Speed	HMC_V6
Version:	a 153589 from 18.12.97		657765.49.07	
File:	CHAP_8.DOC	650H0000	Sourcefile:07800601.00H	Page 40 / 60

Calibration data:

Name	Dim	Hex. limits	Phys. limits	Resol.	Unit
C_ISAPWM_MIN_I	1	8000...7FFFH	-50...49,998	1,526E-3	%
Minimum integral component out of idle.					
C_ISAPWM_MAX_I	1	8000...7FFFH	-50...49,998	1,526E-3	%
Maximum integral component out of idle.					
C_ISAPWM_ACCIN_MIN_I	1	8000...7FFFH	-50...49,998	1,526E-3	%
Minimum integral component out of idle with air condition compressor active.					
C_ISAPWM_ACCIN_MAX_I	1	8000...7FFFH	-50...49,998	1,526E-3	%
Maximum integral component out of idle with air condition compressor active.					
C_ISAPWM_LGRD	1	01...FFH	0,098...24,902	0,098	% / 40ms
Idle controller change limitation.					
C_ISAPWM_MIN_I_IS	1	8000...7FFFH	-50...49,998	1,526E-3	%
Minimum integral component in idle and vehicle stopped.					
C_ISAPWM_MAX_I_IS	1	8000...7FFFH	-50...49,998	1,526E-3	%
Maximum integral component in idle and vehicle stopped.					
C_ISAPWM_VS_MIN_I_IS	1	8000...7FFFH	-50...49,998	1,526E-3	%
Minimum integral component in idle and vehicle running.					
C_ISAPWM_VS_MAX_I_IS	1	8000...7FFFH	-50...49,998	1,526E-3	%
Maximum integral component in idle and vehicle running.					
C_ISAPWM_VS_ACCIN_MIN_I_IS	1	8000...7FFFH	-50...49,998	1,526E-3	%
Minimum integral component in idle with vehicle running and air condition compressor active.					
C_ISAPWM_VS_ACCIN_MAX_I_IS	1	8000...7FFFH	-50...49,998	1,526E-3	%
Maximum integral component in idle with vehicle running and air condition compressor active.					
C_T_MAX_IS	1	01...FFFFH	0,01...655,35	0.01	s
Time delay to detect vehicle running.					
C_ISAPWM_N_GRD_I_ADD	1	80...00H	-4096...0	32	rpm/sec
Minimum engine speed gradient to have rapid engine speed drop.					
C_ISAPWM_I_ADD	1	00...FFFFH	0...99,998	1,526E-3	%
Integral component correction in case of rapid engine speed drop.					
C_ISAPWM_LGRD_D	1	01...FFH	0.098...24,902	0,098	% / 40ms
Derivative component change limitation.					

Proprietary data, company confidential. All rights reserved.
 Contient des informations confidentielles. Tous droits réservés.
 Comunicado como secreto empresarial. Reservados todos los derechos.
 Confidado como secreto industrial. Nos reservamos todos los derechos.

Weitergabe sowie Vervielfältigung dieser Unterlage, Verwertung und Mitteilung ihres Inhalts ist gestattet, soweit nicht ausdrücklich zugestanden. Zuwiderhandlungen verpflichten zu Schadensersatz. Alle Rechte vorbehalten, insbesondere für den Fall der Patenterteilung oder GM-Entragung.

Editor: Müller O.	17-Dec-97	Idle Speed	HMC_V6
Version: a 153589 from 18.12.97		657765.49.07	
File: CHAP_8.DOC	650H0000	Sourcefile:07800601.00H	Page 41 / 60

1.8 Idle speed adaptation (ISAPWM_xx_AD_MMV_IS)

Output data:

Name	Mode	Hex. limits	Phys. limits	Resol.	Unit
ISAPWM_AD_MMV_IS	V/S	8000...7FFFH	-50...49.998	1.526E-3	%
Adaptive value without DRIVE engaged					
ISAPWM_DRI_AD_MMV_IS	V/S	8000...7FFFH	-50...49.998	1.526E-3	%
Adaptive value with DRIVE engaged					
ISAPWM_ACCIN_AD_MMV_IS	V/S	8000...7FFFH	-50...49.998	1.526E-3	%
Adaptive value with air conditioner compressor active					
ISAPWM_MMV_IS	V	8000...7FFFH	-50...49.998	1.526E-3	%
Idle speed regulation average value					
ISAPWM_AD_IS	V/S	8000...7FFFH	-50...49.998	1.526E-3	%
Non filtered adaptive value of idle speed regulation					
ISAPWM_AD_COR_IS	V/S	8000...7FFFH	-50...49.998	1.526E-3	%
Corrected adaptive value of idle speed regulation					
LV_ISAPWM_AD_DYW_IS	V	0...01H	0...1	1	-
Boolean for constant ISAPWM conditions to allow idle speed adaptation (- / ISAPWM).					
LV_N_AD_DYW_IS	V	0...01H	0...1	1	-
Boolean for constant N conditions to allow idle speed adaptation (- / N).					

Input data:

ISAPWM_TRA_ACCIN	LV_VS_ERR	LV_DRI	IP_ISAPWM_ACCIN_N_MAF_N_SP_IS_MAF_ALTI_COR
LV_ES	LV_ST	LV_IS	LV_CT
N	N_32	TCO	VB
VS	LV_RLY_ACCOUT_CTRL	LV_CPS_MECHA_ERR	ISAPWM_IS
LV_TPS_ERR	LV_TPS_PLAUS_ERR	LV_MAF_ERR	LV_MAF_PLAUS_ERR
LV_TCO_ERR	LV_TCO_PLAUS_ERR	LV_IV_[CYL]_ERR	LV_TIA_ERR
LV_VLS_LIM_i_ERR	N_SP_IS	LV_LAM_LIM_i_ERR	NC_ISAPWM_N_MAX
LV_ISA_i_ERR	LV_STATE_A_MIS	LV_ISA_MECHA_ERR	LV_TIMEOUT_TCU1_ERR
LV_DUR_IGC_[CYL]_ERR	LV_CPS_ERR	LV_VLS_UP_i_ERR	

1.8.1 General information

Unmetered air and other effects of ageing cause deviations in the duty cycle between the basic idle-charge actuator opening and the idle speed regulation value.

This deviation must be detected and corrected by an offset :

- MT Car or AT Car not in DRIVE (LV_DRI = -) ---> **ISAPWM_AD_MMV_IS**
(stored in a non volatile memory)
- AT with DRIVE engaged (LV_DRI = DRI) ---> **ISAPWM_DRI_AD_MMV_IS**
(stored in a non volatile memory)
- LV_RLY_ACCOUT_CTRL = 1 (A/C active) ---> **ISAPWM_ACCIN_AD_MMV_IS**
(partially stored in a volatile memory)

If $N < NC_ISAPWM_N_MAX$, the application recurrence is **10 msec**, otherwise **40 msec**.

Editor: Müller O.	17-Dec-97	Idle Speed	HMC_V6
Version: a 153589 from 18.12.97		657765.49.07	
File: CHAP_8.DOC	650H0000	Sourcefile:07800701.00I	Page 42 / 60

** Initialization :*

The adaptation values are initialized when the engine is started for the first time or by the after-sales customer service :

```
ISAPWM_AD_MMV_IS           = 00H
ISAPWM_DRI_AD_MMV_IS      = 00H
ISAPWM_ACCIN_AD_MMV_IS    = 00H
```

** Adaptation values applicability :*

The determined adaptation value causes a partial shift of the basic idle-charge actuator opening.

But adaptation with air condition compressor is subject to the following conditions :

a) - it must be ensured that the weighting table

IP_ISAPWM_ACCIN_N_MAF__N_SP_IS__MAF_ALTI_COR contains the value 1 within the index table area which allows adaptation.

b) - adaptation should be possible only after the load increase factor has reached 1, and ISAPWM_TRA_ACCIN the value 0 (this must be ensured by application).

1.8.2 Adaptation conditions

a) Engine operating state engine stopped (LV_ES) or start (LV_ST) not active.

b) The presence of a diagnosis error, influencing the idle detection or the idle air quantity is not permitted :

```

LV_TPS_ERR = 0           (throttle position sensor)
and LV_TPS_PLAUS_ERR = 0
and LV_TCO_ERR = 0       (coolant temperature sensor)
and LV_TCO_PLAUS_ERR = 0
and LV_MAF_ERR = 0       (mass air flow sensor)
and LV_MAF_PLAUS_ERR = 0
and LV_TIA_ERR = 0       (intake air temperature sensor)
and LV_VS_ERR = 0        (vehicle speed signal)
and LV_IV_[CYL]_ERR = 0  (injector valves 0..5)
and LV_DUR_IGC_[CYL]_ERR = 0 (ignition)
and LV_ISA_i_ERR = 0     (idle speed actuator)
and LV_ISA_MECHA_ERR = 0
and LV_TIMEOUT_TCU1_ERR = 0 (timeout from TCU)
and LV_STATE_A_MIS = 0  (misfire CARB A)
and LV_CPS_ERR = 0       (canister purge solenoid)
and LV_CPS_MECHA_ERR = 0
and LV_VLS_UP_i_ERR = 0  (upstream O2 sensor signal)
and LV_VLS_LIM_i_ERR = 0 (lambda probe voltage excursion)
and LV_LAM_LIM_i_ERR = 0 (lambda controller at limit)
```

Editor:	Müller O.	17-Dec-97	Idle Speed	HMC_V6
Version:	a 153589 from 18.12.97		657765.49.07	
File:	CHAP_8.DOC	650H0000	Sourcefile:07800701.00I	Page 43 / 60

Proprietary data, company confidential. All rights reserved.
 Contient des informations confidentielles. Tous droits réservés.
 Contiene datos de la compañía confidencial. Reservados todos los derechos.
 Comunicado como segredo empresarial. Reservados todos os direitos.
 Confidado como secreto industrial. Nos reservamos todos los derechos.

- c) Throttle closed (LV_CT = 1) for more than ID_CYCNR_IS__N_32 seconds.
(in order to allow the throttle to settle after closing)
- d) The coolant temperature must lie within following limits:
 - d1) For ISAPWM_AD_MMV_IS and ISAPWM_DRI_AD_MMV_IS:
 $C_TCO_AD_MIN_IS \leq TCO \leq C_TCO_AD_MAX_IS$
 - d2) For ISAPWM_ACCIN_AD_MMV_IS:
 $C_TCO_ACCIN_AD_MIN_IS \leq TCO \leq C_TCO_AD_MAX_IS$
- e) No nominal engine speed increase at idle (LV_IS) must be effective due to an insufficient battery voltage VB.
- f) VS = 0

1.8.3 Adaptation sequence

1.8.3.1 Adaptation process

The aim is the determination of a steadily settled idle speed regulation ISAPWM_IS.

Weitergabe sowie Veröffentlichung dieser Unterlage, Verwertung und Mitteilung ihres Inhalts nicht gestattet, soweit nicht ausdrücklich zugestanden. Zuwiderhandlungen verpflichten zu Schadensersatz. Alle Rechte vorbehalten, insbesondere für den Fall der Patenterteilung oder GM-Eintragung.

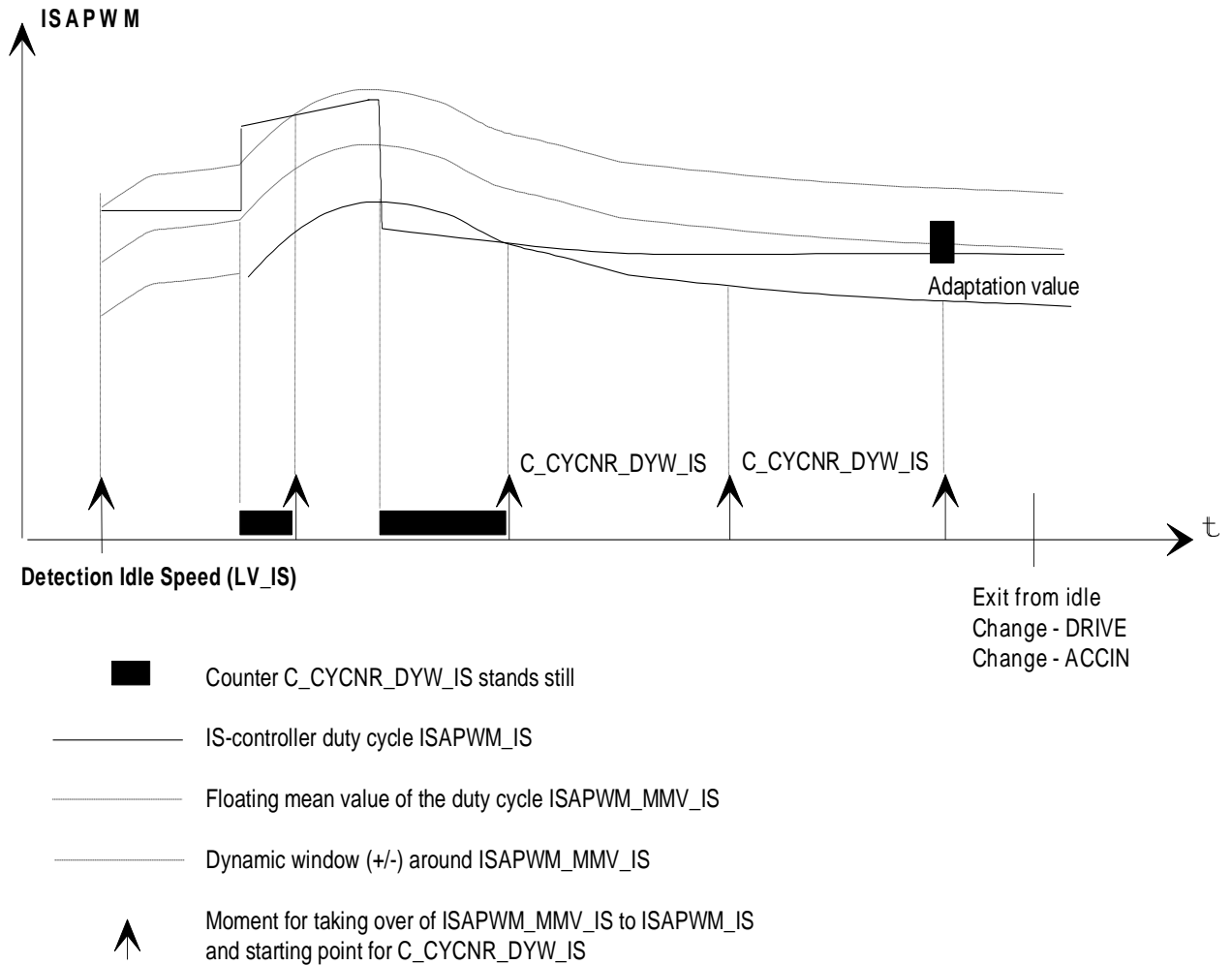

Editor: Müller O.	17-Dec-97	Idle Speed	HMC_V6
Version: a 153589 from 18.12.97		657765.49.07	
File: CHAP_8.DOC	650H0000	Sourcefile:07800701.00I	Page 44 / 60

Proprietary data, company confidential. All rights reserved.
 Contit a titre de secret d'entreprise. Tous droits réservés.
 Comunicado como segredo empresarial. Reservados todos os direitos.
 Confidado como secreto industrial. Nos reservamos todos los derechos.

Weitergabe sowie Vervielfältigung dieser Unterlage, Verwertung und Mitteilung ihres Inhalts nicht gestattet, soweit nicht ausdrücklich zugestanden. Zuwiderhandlungen verpflichten zu Schadensersatz. Alle Rechte vorbehalten, insbesondere für den Fall der Patenterteilung oder GM-Entragung

*** ISAPWM_MMV_IS calculation :**

The moving mean value of the idle speed regulation correction is defined as :

$$ISAPWM_MMV_IS_{(n)} = ISAPWM_MMV_IS_{(n-1)} + (ISAPWM_IS_{(n)} - ISAPWM_MMV_IS_{(n-1)}) * C_ISAPWM_CRLC_IS$$

When entering in the engine operating state idle (LV_IS), the first value of the idle speed regulation is used as moving mean value.

A dynamic window is placed around ISAPWM_IS and N at intervals of 40 ms :

```

If          during C_CYCNR_DYW_IS, the following conditions are true :
    a) -      | ISAPWM_IS - ISAPWM_MMV_IS | < C_ISAPWM_AD_DYW_IS
              ⇔ LV_ISAPWM_AD_DYW_IS = 1 (ISAPWM)
    and      b) -      | N - N_SP_IS | < C_N_AD_DYW_IS
              ⇔ LV_N_AD_DYW_IS = 1 (N)
then       ISAPWM_AD_IS = ISAPWM_MMV_IS
    
```

This process is repeated again as often as the adaptation conditions are true.

*** ISAPWM_AD_COR_IS calculation :**

When exiting from idle, this value represents the target for the I component of the idle speed regulation.

```

If          idle adaptation calculation is not yet performed
              (no update of idle adaptation calculation)
then       ISAPWM_AD_COR_IS = ISAPWM_AD_IS
else       ISAPWM_AD_COR_IS = ISAPWM_AD_IS * (1 - C_AD_CRLC_IS)
    
```

After use, ISAPWM_AD_IS is set to **0**.

Editor:	Müller O.	17-Dec-97	Idle Speed	HMC_V6
Version:	a 153589 from 18.12.97		657765.49.07	
File:	CHAP_8.DOC	650H0000	Sourcefile:07800701.00I	Page 45 / 60

1.8.3.2 Adaptation calculation

a) Air condition compressor is **OFF** (LV_RLY_ACCOUT_CTRL = 0)

A new ISAPWM_xx_AD_MMV_IS calculation is performed for the concerned adaptative term according to the following conditions :

If LV_IS = 1 (engine operating state Idle)
if A/T shift NEUTRAL ---> DRIVE
and air condition compressor is **OFF** (LV_RLY_ACCOUT_CTRL = 0)
or M/T or A/T in NEUTRAL position
and air condition compressor is switched **ON** (LV_RLY_ACCOUT_CTRL 0->1)
or Change of operating state from IS → PL
and air condition compressor is **OFF** (LV_RLY_ACCOUT_CTRL = 0)
and M/T or A/T in NEUTRAL position
then

$$ISAPWM_AD_MMV_IS_{(n)} = ISAPWM_AD_MMV_IS_{(n-1)} + ISAPWM_AD_IS_{(n)} * C_AD_CRLC_IS$$

If LV_IS = 1 (engine operating state Idle)
if A/T shift DRIVE ---> NEUTRAL
and air condition compressor is **OFF** (LV_RLY_ACCOUT_CTRL = 0)
or A/T in DRIVE position
and air condition compressor is switched **ON** (LV_RLY_ACCOUT_CTRL 0->1)
or Change of operating state from IS → PL
and air condition compressor is **OFF** (LV_RLY_ACCOUT_CTRL = 0)
and A/T in DRIVE position
then

$$ISAPWM_DRI_AD_MMV_IS_{(n)} = ISAPWM_DRI_AD_MMV_IS_{(n-1)} + ISAPWM_AD_IS_{(n)} * C_AD_CRLC_IS$$

b) Air condition compressor is **ON** (LV_RLY_ACCOUT_CTRL = 1)

A new ISAPWM_ACCIN_AD_MMV_IS calculation is performed according to the following conditions :

If LV_IS = 1 (engine operating state Idle)
and air condition compressor is switched **OFF** (LV_RLY_ACCOUT_CTRL 1->0)
or Change of operating state from IS → PL
and air condition compressor is **ON** (LV_RLY_ACCOUT_CTRL = 1)
then

$$ISAPWM_ACCIN_AD_MMV_IS_{(n)} = ISAPWM_ACCIN_AD_MMV_IS_{(n-1)} + ISAPWM_AD_IS_{(n)} * C_AD_CRLC_IS$$

Proprietary data, company confidential. All rights reserved.
 Contit a titre de secret d'entreprise. Tous droits réservés.
 Comunicado como segredo empresarial. Reservados todos os direitos.
 Confidado como secreto industrial. Nos reservamos todos los derechos.

Weitergabe sowie Vervielfältigung dieser Unterlage, Verwertung und Mitteilung ihres Inhalts nicht gestattet, soweit nicht ausdrücklich zugestanden. Zuwiderhandlungen verpflichten zu Schadenersatz. Alle Rechte vorbehalten, insbesondere für den Fall der Patenterteilung oder GM-Entragung

Editor: Müller O.	17-Dec-97	Idle Speed	HMC_V6
Version: a 153589 from 18.12.97		657765.49.07	
File: CHAP_8.DOC	650H0000	Sourcefile:07800701.00I	Page 46 / 60

Contrary to ISAPWM_AD_MMV_IS and ISAPWM_DRI_AD_MMV_IS the air condition compressor adaptation value is not stored completely in the non volatile memory at the end of the controller holding phase.

As the demand may have changed after the following engine start (influence of ambient temperature), the value ISAPWM_ACCIN_AD_MMV_IS is reduced by multiplication of C_ISAPWM_ACCIN_AD_FAC before it is stored in the non volatile memory.

1.8.3.3 Adaptation limits

a) For **ISAPWM_AD_MMV_IS** and **ISAPWM_DRI_AD_MMV_IS** the limitation is:

$$C_ISAPWM_AD_MIN_IS \leq ISAPWM_AD_MMV_IS \leq C_ISAPWM_AD_MAX_IS$$

$$C_ISAPWM_AD_MIN_IS \leq ISAPWM_DRI_AD_MMV_IS \leq C_ISAPWM_AD_MAX_IS$$

b) For **ISAPWM_ACCIN_AD_MMV_IS** the limitation is:

$$C_ISAPWM_ACCIN_AD_MIN_IS \leq ISAPWM_ACCIN_AD_MMV_IS \leq C_ISAPWM_ACCIN_AD_MAX_IS$$

c) For **ISAPWM_AD_COR_IS** the limitation is:

* Air condition compressor **OFF** (LV_RLY_ACCOUT_CTRL = 0):

$$C_ISAPWM_MIN_I \leq ISAPWM_AD_COR_IS \leq C_ISAPWM_MAX_I$$

* Air condition compressor **ON** (LV_RLY_ACCOUT_CTRL = 1):

$$C_ISAPWM_ACCIN_MIN_I \leq ISAPWM_AD_COR_IS \leq C_ISAPWM_ACCIN_MAX_I$$

Editor:	Müller O.	17-Dec-97	Idle Speed	HMC_V6
Version:	a 153589 from 18.12.97		657765.49.07	
File:	CHAP_8.DOC	650H0000	Sourcefile:07800701.00I	Page 47 / 60

Calibration data:

Name	Dim	Hex. limits	Phys. limits	Resol.	Unit
ID_CYCNR_IS_N_32	4	01...FFH	0.04...10.2	0.04	sec
Delay to allow idle adaptation when LV_CT is true.					
C_TCO_AD_MIN_IS	1	0...FEH	-48...142.5	0.75	°C
Minimum coolant temperature for idle adaptation without air condition compressor.					
C_TCO_ACCIN_AD_MIN_IS	1	0...FEH	-48...142.5	0.75	°C
Minimum coolant temperature for idle adaptation with air condition compressor.					
C_TCO_AD_MAX_IS	1	0...FEH	-48...142.5	0.75	°C
Maximum coolant temperature for idle adaptation.					
C_ISAPWM_CRLC_IS	1	00...FFH	0...0.997	3.895E-3	-
Filtering factor for ISAPWM_MMV_IS.					
C_CYCNR_DYW_IS	1	01...FFH	1...255	1	-
Minimum time for (N, ISAPWM) steady state condition to calculate a new ISAPWM_AD_IS (x 40 msec)					
C_ISAPWM_AD_DYW_IS	1	0...FFFFH	0...99.9985	0.0015	%
Steady state threshold for ISAPWM_IS to learn ISAPWM_AD_IS.					
C_N_AD_DYW_IS	1	0...FFH	0...255	1	rpm
Steady state threshold for engine speed to learn ISAPWM_AD_IS.					
C_AD_CRLC_IS	1	00...FFH	0...0.997	3.895E-3	-
Filtering factor for adaptive term.					
C_ISAPWM_ACCIN_AD_FAC	1	00...FFH	0...0.997	3.895E-3	-
Reduction factor for ISAPWM_ACCIN_AD_MMV_IS when stored in non volatile memory.					
C_ISAPWM_AD_MIN_IS	1	8000...0000H	-50...0	0.0015	%
Minimum adaptive value without air condition compressor.					
C_ISAPWM_AD_MAX_IS	1	0...7FFFH	0...49.9985	0.0015	%
Maximum adaptive value without air condition compressor.					
C_ISAPWM_ACCIN_AD_MIN_IS	1	8000...0000H	-50...0	0.0015	%
Minimum adaptive value with air condition compressor.					
C_ISAPWM_ACCIN_AD_MAX_IS	1	0...7FFFH	0...49.9985	0.0015	%
Maximum adaptive value with air condition compressor.					
C_ISAPWM_MIN_I	1	8000...7FFFH	-50...49.998	1.526E-3	%
Minimum integral component out of idle without air condition compressor.					
C_ISAPWM_MAX_I	1	8000...7FFFH	-50...49.998	1.526E-3	%
Maximum integral component out of idle without air condition compressor.					
C_ISAPWM_ACCIN_MIN_I	1	8000...7FFFH	-50...49.998	1.526E-3	%
Minimum integral component out of idle with air condition compressor.					
C_ISAPWM_ACCIN_MAX_I	1	8000...7FFFH	-50...49.998	1.526E-3	%
Maximum integral component out of idle with air condition compressor.					

Proprietary data, company confidential. All rights reserved.
 Contine a titre de secret d'entreprise. Tous droits réservés.
 Comunicado como segredo empresarial. Reservados todos os direitos.
 Confidado como secreto industrial. Nos reservamos todos los derechos.

Weitergabe sowie Vervielfältigung dieser Unterlage, Verwertung und Mitteilung ihres Inhalts nicht gestattet, soweit nicht ausdrücklich zugestanden. Zuwiderhandlungen verpflichten zu Schadensersatz. Alle Rechte vorbehalten, insbesondere für den Fall der Patenterteilung oder GM-Entragung.

Editor: Müller O.	17-Dec-97	Idle Speed	HMC_V6
Version: a 153589 from 18.12.97		657765.49.07	
File: CHAP_8.DOC	650H0000	Sourcefile:07800701.001	Page 48 / 60

1.9 Intake air temperature correction (ISAPWM_TIA_FAC)

Output data:

Name	Mode	Hex. limits	Phys. limits	Resol.	Unit
ISAPWM_TIA_FAC	V/S	00...FFH	0...1,922	7,509E-3	-
Intake air temperature correction.					

Input data:

TIA		
-----	--	--

FUNCTION DESCRIPTION:

General information:

The linear opening ratio ISAPWM is converted to standard condition TIA = 20 °C (intake air temperature) by means of air-density correction ISAPWM_TIA_FAC.

The application recurrence is **500 msec.**

Application conditions:

Available for all engine operating states.

Formula section:

$$ISAPWM_TIA_FAC = IP_ISAPWM_TIA_FAC_TIA$$

Calibration data:

Name	Dim	Hex. limits	Phys. limits	Resol.	Unit
IP_ISAPWM_TIA_FAC_TIA	6	0...FFH	0...1,9922	0,0078	-
Intake air temperature correction factor					

Proprietary data, company confidential. All rights reserved. Contient a titre de secret d'entreprise. Tous droits réservés. Comunicado como segredo empresarial. Reservados todos os direitos. Confidado como secreto industrial. Nos reservamos todos los derechos.

Weitergabe sowie Vervielfältigung dieser Unterlage, Wertung und Mitteilung ihres Inhalts nicht gestattet, soweit nicht ausdrücklich zugestanden. Zuwiderhandlungen verpflichten zu Schadenersatz. Alle Rechte vorbehalten, insbesondere für den Fall der Patenterteilung oder GM-Entragung.

Editor: Müller O.	17-Dec-97	Idle Speed	HMC_V6
Version: a 153589 from 18.12.97		657765.49.07	
File: CHAP_8.DOC	650H0000	Sourcefile:07800901.00D	Page 49 / 60

1.10 Idle-charge Actuator Adaptation (AD_MMV_ISA, ADD_ISA)

Output data:

Name	Mode	Hex. limits	Phys. limits	Resol.	Unit
AD_MMV_ISA	V	00...FFFFH	0...2,000	3,052E-5	-
Idle-charge actuator adaptation.					
ADD_ISA	V	00...FFFFH	0...2,000	3,052E-5	-
Target air mass and measured air mass comparison in idle.					
AD_INI_COR_ISA	V/S	00...FFH	0...1,992	7,782E-3	-
Initialization of idle-charge actuator adaptation.					
LV_MAF_AD_MAX_ISA	V	0...01H	0...1	1	-
Boolean for critical pressure ratio detection (- / MAF_MAX).					
LV_AD_PREV_ISA	V	0...01H	0...1	1	-
Boolean to inform if an idle - charge actuator adaptation has previously occurred (- / YES).					

Input data:

TPS	TIA	ISAPWM	N_32
MAF	MAF_KGH	MAF_ALTI_COR	C_MAF_MAX_ISA
ISAPWM_TIA_FAC	ID_CYCNR_IS__N	LV_CT	LV_ES
LV_TPS_ERR	LV_TPS_PLAUS_ERR	LV_MAF_ERR	LV_MAF_PLAUS_ERR
LV_TIA_ERR	LV_ISA_i_ERR	LV_ISA_MECHA_ERR	

1.10.1 Adaptation conditions

These conditions are checked with a recurrence of **300 msec.**

- a) - The presence of an error influencing the idle detection or the idle air quantity is not permitted :

- LV_TPS_ERR = 0 (throttle position sensor)
- and** LV_TPS_PLAUS_ERR = 0 (throttle position sensor - plausibility)
- and** LV_MAF_ERR = 0 (mass air flow sensor)
- and** LV_MAF_PLAUS_ERR = 0 (mass air flow sensor - plausibility)
- and** LV_TIA_ERR = 0 (air intake temperature sensor)
- and** LV_ISA_i_ERR = 0 (idle speed actuator - electrical)
- and** LV_ISA_MECHA_ERR = 0 (idle speed actuator - mechanical)

- b) - Throttle closed (LV_CT = CT) since more than ID_CYCNR_IS__N seconds.

- c) - The calculated idle - charge actuator opening must be within the following limits :

$$C_ISAPWM_AD_MIN_ISA \leq ISAPWM \leq C_ISAPWM_AD_MAX_ISA$$

Proprietary data, company confidential. All rights reserved. Contine a titre de secret d'entreprise. Tous droits réservés. Comunicado como segredo empresarial. Reservados todos os direitos. Confidado como secreto industrial. Nos reservamos todos los derechos.

Weitergabe sowie Vervielfältigung dieser Unterlage, Verwertung und Mitteilung ihres Inhalts nicht gestattet, soweit nicht ausdrücklich zugestanden. Zuwiderhandlungen verpflichten zu Schadensersatz. Alle Rechte vorbehalten, insbesondere für den Fall der Patenterteilung oder GM-Entragung.

Editor: Müller O.	17-Dec-97	Idle Speed	HMC_V6
Version: a 153589 from 18.12.97		657765.49.07	
File: CHAP_8.DOC	650H0000	Sourcefile:07800A01.00G	Page 50 / 60

Proprietary data, company confidential. All rights reserved.
 Contine a titre de secret d'entreprise. Tous droits réservés.
 Comunicado como secreto empresarial. Reservados todos os direitos.
 Confidado como secreto industrial. Nos reservamos todos los derechos.

Weitergabe sowie Vervielfältigung dieser Unterlage, Verwertung und Mitteilung ihres Inhalts nicht gestattet, soweit nicht ausdrücklich zugestanden. Zuwiderhandlungen verpflichten zu Schadensersatz. Alle Rechte vorbehalten, insbesondere für den Fall der Patenterteilung oder GM-Eintragung

- d) - The idle - charge actuator adaptation must be performed with a critical pressure ratio at the throttle (**sound velocity**).

This condition is met dependent on the engine speed up to an air mass flow of IP_MAF_AD_MAX_ISA__N_32.

- The influence of the altitude is compensated using the mass air flow corrected to sea level **MAF_ALTI_COR** in the calculation.
- The influence of the density due to the ambient air temperature is compensated by multiplication by **ISAPWM_TIA_FAC**.

The critical pressure ratio status is performed with the following conditions :

```

if     MAF_ALTI_COR * ISAPWM_TIA_FAC < IP_MAF_AD_MAX_ISA__N_32
then  LV_MAF_AD_MAX_ISA = 1 (MAF_MAX)
else  LV_MAF_AD_MAX_ISA = 0 (-).
    
```

Remark :

Once an adaptation of the idle-charge characteristic has occurred, LV_AD_PREV_ISA is set to 1 (YES).

Editor:	Müller O.	17-Dec-97	Idle Speed	HMC_V6
Version:	a 153589 from 18.12.97		657765.49.07	
File:	CHAP_8.DOC	650H0000	Sourcefile:07800A01.00G	Page 51 / 60

1.10.2 Adaptation of the idle-charge actuator characteristic

When the adaptation conditions are true, the air mass measured is converted to kg/h at intervals of **300 msec** and reduced to the reference conditions for the idle - charge actuator.

* **ADD_ISA** calculation :

The comparison of the target air mass and the measured air mass results in the correction factor for idle - charge actuator adaptation :

ADD_ISA = Fehler!

ADD_ISA = Fehler!

Remark :

- The air flow through the idle - charge actuator and the throttle body when they are completely closed is represented by C_MAF_AD_ISA and C_MAF_MAX_ISA.
- The target air mass is reduced to the reference conditions by using ISAPWM_TIA_FAC in the calculation.

* **AD_MMV_ISA** calculation :

The duty cycle correction AD_MMV_ISA is formed by means of the moving mean value :

$$AD_MMV_ISA_{(n)} = AD_MMV_ISA_{(n-1)} * [1 + C_AD_CRLC_ISA * (ADD_ISA_{(n)} - 1)]$$

- A proportional change in the air mass cannot be transferred proportionally to the idle - charge actuator control due to linearization of the characteristic. Then it must be : $C_AD_CRLC_ISA < 1$.

- In order to provide sufficient air for all conditions possible, the idle - charge actuator adaptation has a lower limit. This is defined in terms of the value C_AD_DIF_MMV_ISA which specifies the maximum interval to the initialization characteristic of the idle - charge actuator adaptation.

$$AD_MMV_ISA \geq IP_AD_INI_ISA_TIA - C_AD_DIF_MMV_ISA$$

Proprietary data, company confidential. All rights reserved. Contine a titre de secret d'entreprise. Tous droits réservés. Comunicado como segredo empresarial. Reservados todos os direitos. Confidado como secreto industrial. Nos reservamos todos los derechos.

Weitergabe sowie Vervielfältigung dieser Unterlage, Verwertung und Mitteilung ihres Inhalts nicht gestattet, soweit nicht ausdrücklich zugestanden. Zuwiderhandlungen verpflichten zu Schadenersatz. Alle Rechte vorbehalten, insbesondere für den Fall der Patenterteilung oder GM-Entragung.

Editor: Müller O.	17-Dec-97	Idle Speed	HMC_V6
Version: a 153589 from 18.12.97		657765.49.07	
File: CHAP_8.DOC	650H0000	Sourcefile:07800A01.00G	Page 52 / 60

1.10.3 Initialization of idle-charge actuator adaptation

At a new start, after the controller has been reset, the correction AD_MMV_ISA of the idle - charge actuator characteristic is initialized as following :

$$AD_MMV_ISA = IP_AD_INI_ISA_TIA * AD_INI_COR_ISA$$

*** AD_INI_COR_ISA initialization :**

It is saved in a non - volatile memory from previous engine running.

It is initialized to **1** following a restart, if the car is new or by the after - sales customer service or if a bad saving has been previously performed.

*** AD_INI_COR_ISA calculation conditions :**

a) - The presence of the following errors is not permitted :

- LV_TPS_ERR = 0 (throttle position sensor)
- and** LV_TPS_PLAUS_ERR = 0
- and** LV_MAF_ERR = 0 (mass air flow sensor)
- and** LV_MAF_PLAUS_ERR = 0
- and** LV_TIA_ERR = 0 (air intake temperature sensor)
- and** LV_ISA_i_ERR = 0 (idle - charge actuator / mechanical)
- and** LV_ISA_MECHA_ERR = 0

b) - The engine is stopped (LV_ES - power latch phase) and the post-start function was previously over.

The calculation is made only once.

If the above - mentioned conditions are not fulfilled, the old value is taken in account :

$$AD_INI_COR_ISA_{(n)} = AD_INI_COR_ISA_{(n-1)}$$

*** AD_INI_COR_ISA calculation :**

Previously, when the engine is stopped (power latch phase), to take in account the typical variances of the idle - charge actuator during operation, the value AD_INI_COR_ISA is calculated for the next starting as following :

$$AD_INI_COR_ISA = \text{Fehler!}$$

with C_AD_ADD_MMV_ISA a variable applicable to influence the idle - charge actuator adaptation value at start.

Proprietary data, company confidential. All rights reserved. Contine a titre de secret d'entreprise. Tous droits réservés. Comunicado como segredo empresarial. Reservados todos os direitos. Confidado como secreto industrial. Nos reservamos todos los derechos.

Weitergabe sowie Vervielfältigung dieser Unterlage, Verwertung und Mitteilung ihres Inhalts nicht gestattet, soweit nicht ausdrücklich zugestanden. Zuwiderhandlungen verpflichten zu Schadenersatz. Alle Rechte vorbehalten, insbesondere für den Fall der Patenterteilung oder GM-Entragung.

Editor: Müller O.	17-Dec-97	Idle Speed	HMC_V6
Version: a 153589 from 18.12.97		657765.49.07	
File: CHAP_8.DOC	650H0000	Sourcefile:07800A01.00G	Page 53 / 60

Calibration data:

Name	Dim	Hex. limits	Phys. limits	Resol.	Unit
C_ISAPWM_AD_MIN_ISA	1	00...FFH	0...99,609	0,3891	%
Minimum ISAPWM for idle-charge actuator characteristic adaptation.					
C_ISAPWM_AD_MAX_ISA	1	00...FFH	0...99,609	0,3891	%
Maximum ISAPWM for idle-charge actuator characteristic adaptation.					
IP_MAF_AD_MAX_ISA_N_32	3	0...FFH	0...1389	5,44	mg/TDC
Maximum air flow for idle-charge actuator characteristic adaptation.					
C_MAF_AD_ISA	1	0...FFH	0...63,75	0,25	kg/h
Air flow through the throttle body in normal conditions.					
C_AD_CRLC_ISA	1	00...FFH	0...0,997	3,895E-3	-
Correlation factor for calculation of AD_MMV_ISA.					
C_AD_DIF_MMV_ISA	1	00...FFH	0...1,992	7,782E-3	-
Maximum difference between the idle-charge actuator adaptation and the initialization characteristic.					
IP_AD_INI_ISA_TIA	6	00...FFH	0...1,922	7,509E-3	-
Initialization of the idle-charge actuator.					
C_AD_ADD_MMV_ISA	1	00...FFH	0...1,992	7,782E-3	-
Offset for the idle-charge actuator adaptation value at start.					

Proprietary data, company confidential. All rights reserved.
 Contine a titre de secret d'entreprise. Tous droits réservés.
 Comunicado como segredo empresarial. Reservados todos os direitos.
 Confidado como secreto industrial. Nos reservamos todos los derechos.

Weitergabe sowie Vervielfältigung dieser Unterlage, Verwertung und Mitteilung ihres Inhalts nicht gestattet, soweit nicht ausdrücklich zugestanden. Zuwiderhandlungen verpflichten zu Schadensersatz. Alle Rechte vorbehalten, insbesondere für den Fall der Patenterteilung oder GM-Eintragung.

Editor: Müller O.	17-Dec-97	Idle Speed	HMC_V6
Version: a 153589 from 18.12.97		657765.49.07	
File: CHAP_8.DOC	650H0000	Sourcefile:07800A01.00G	Page 54 / 60

1.11 Fans correction (ISAPWM_CFA, ISAPWM_TRA_CFA)

Output data:

Name	Mode	Hex. limits	Phys. limits	Resol.	Unit
ISAPWM_CFA	V	00...FFFFH	0...99,998	1,526E-3	%
Idle charge - actuator opening correction for cooling and condenser fans.					
ISAPWM_TRA_CFA	V	8000...7FFFH	-50...49,998	1,526E-3	%
Idle charge - actuator opening correction when STATE_CFA_IS is changing.					

Input data:

STATE_CFA_IS	LV_ACCIN	VS_STATE_CFA	LV_PRS_ACC
--------------	----------	--------------	------------

FUNCTION DESCRIPTION:

General information:

Its purpose is to correct the cooling and condenser fans power requirements.
It depends on fans state : **OFF / LOW / MIDDLE / HIGH.**

When a fan is switched on or its speed changes, an additional duty cycle is applied in order to ensure a rapid intake pipe filling. This is performed by the ISAPWM_TRA_CFA term.
It is used also when a cooling fan is switched OFF or its speed decreases.

The application recurrence is **40 msec.**

Application conditions:

Available for all engine operating states.

Formula section:

a) - **ISAPWM_CFA** calculation :

	STATE_CFA_IS		
	1	2	3
LV_ACCIN = 0	C_ISAPWM_0_1_CFA	C_ISAPWM_0_2_CFA	C_ISAPWM_0_3_CFA
LV_ACCIN = 1	C_ISAPWM_1_1_CFA	C_ISAPWM_1_2_CFA	C_ISAPWM_1_3_CFA

Proprietary data, company confidential. All rights reserved.
 Contitue a titre de secret d'entreprise. Tous droits réservés.
 Comunicado como segredo empresarial. Reservados todos os direitos.
 Confidado como secreto industrial. Nos reservamos todos los derechos.

Weitergabe sowie Vervielfältigung dieser Unterlage, Verwertung und Mitteilung ihres Inhalts nicht gestattet, soweit nicht ausdrücklich zugestanden. Zuwiderhandlungen verpflichten zu Schadensersatz. Alle Rechte vorbehalten, insbesondere für den Fall der Patenterteilung oder GM-Entragung.

Proprietary data, company confidential. All rights reserved.
 Contine a titre de secret d'entreprise. Tous droits réservés.
 Comunicado como segredo empresarial. Reservados todos os direitos.
 Confidado como secreto industrial. Nos reservamos todos los derechos.

Weitergabe sowie Vervielfältigung dieser Unterlage, Verwertung und Mitteilung ihres Inhalts nicht gestattet, soweit nicht ausdrücklich zugestanden. Zuwiderhandlungen verpflichten zu Schadensersatz. Alle Rechte vorbehalten, insbesondere für den Fall der Patenterteilung oder GM-Entragung.

b) - **ISAPWM_TRA_CFA** calculation:

1 - VS_STATE_CFA= 0

1.1 - STATE_CFA_IS values increases :

If LV_PRS_ACC = 0

then ISAPWM_TRA_CFA is set to C_ISAPWM_INC_0_CFA and reseted using change limitation C_ISAPWM_LGRD_0_CFA

else ISAPWM_TRA_CFA is set to C_ISAPWM_INC_1_CFA and reseted using change limitation C_ISAPWM_LGRD_1_CFA

1.2 - STATE_CFA_IS values decreases :

ISAPWM_TRA_CFA is set to C_ISAPWM_DEC_CFA (positive or negative value) and reset to zero using C_ISAPWM_LGRD_DEC_CFA change limitation.

2 - VS_STATE_CFA ≠ 0

ISAPWM_TRA_CFA = 0

Calibration data:

Name	Dim	Hex. limits	Phys. limits	Resol.	Unit
C_ISAPWM_0_1_CFA	1	0...FFH	0...24,902	0,098	%
Idle charge - actuator opening correction when LV_ACIN = 0 and STATE_CFA_IS = 1					
C_ISAPWM_0_2_CFA	1	0...FFH	0...24,902	0,098	%
Idle charge - actuator opening correction when LV_ACIN = 0 and STATE_CFA_IS = 2					
C_ISAPWM_0_3_CFA	1	0...FFH	0...24,902	0,098	%
Idle charge - actuator opening correction when LV_ACIN = 0 and STATE_CFA_IS = 3					
C_ISAPWM_1_1_CFA	1	0...FFH	0...24,902	0,098	%
Idle charge - actuator opening correction when LV_ACIN = 1 and STATE_CFA_IS = 1					
C_ISAPWM_1_2_CFA	1	0...FFH	0...24,902	0,098	%
Idle charge - actuator opening correction when LV_ACIN = 1 and STATE_CFA_IS = 2					
C_ISAPWM_1_3_CFA	1	0...FFH	0...24,902	0,098	%
Idle charge - actuator opening correction when LV_ACIN = 1 and STATE_CFA_IS = 3					
C_ISAPWM_INC_0_CFA	1	0...FFH	0...24,902	0,098	%
ISAPWM_TRA_CFA set value when STATE_CFA_IS increases and LV_PRS_ACC = 0					
C_ISAPWM_INC_1_CFA	1	0...FFH	0...24,902	0,098	%
ISAPWM_TRA_CFA set value when STATE_CFA_IS increases and LV_PRS_ACC = 1					
C_ISAPWM_LGRD_0_CFA	1	0...FFH	0...24,902	0,098	%
ISAPWM_TRA_CFA reset change limitation after STATE_CFA increase and LV_PRS_ACC = 0					
C_ISAPWM_LGRD_1_CFA	1	0...FFH	0...24,902	0,098	%
ISAPWM_TRA_CFA reset change limitation after STATE_CFA increase and LV_PRS_ACC = 1					
C_ISAPWM_DEC_CFA	1	80...7FH	-12,5...12,402	0,098	%
ISAPWM_TRA_CFA set value if STATE_CFA_IS decreased					
C_ISAPWM_LGRD_DEC_CFA	1	0...FFH	0...24,902	0,098	%
ISAPWM_TRA_CFA reset change limitation after STATE_CFA decrease					

Editor: Müller O.	17-Dec-97	Idle Speed	HMC_V6
Version: a 153589 from 18.12.97		657765.49.07	
File: CHAP_8.DOC	650H0000	Sourcefile:07800D01.00E	Page 56 / 60

1.12 ISAPWM-correction for programmed idle speed increase

Output data:

Name	Mode	Hex. limits	Phys. limits	Resol.	Unit
ISAPWM_N_SP_IS_ASA	V	0...FFFFH	0...99,998	1,526E-3	%
Correction for programmed idle speed increase					

Input data:

N_SP_IS_ADJ_ASA	TCO		
-----------------	-----	--	--

FUNCTION DESCRIPTION:

General information:

- The application recurrency is **40 msec**.

Application conditions:

The nominal idle speed can be increased via the serial interface by N_SP_IS_ADJ_ASA which is weighted with a TCO-depending factor. To compensate the air which is needed more, compared to the normal nominal idle speed, the pre-control of the idle charge actuator is additive corrected with ISAPWM_N_SP_IS_ASA.

If LV_IS = 1.

then ISAPWM_N_SP_IS_ASA =

$$IP_ISAPWM_N_SP_IS_ASA_N_SP_IS_ADJ_ASA * IP_ISAPWM_FAC_N_SP_IS_ASA_TCO$$

Calibration data:

Name	Dim	Hex. limits	Phys. limits	Resol.	Unit
IP_ISAPWM_N_SP_IS_ASA_N_SP_IS_ADJ_ASA	6	0...FFH	0...99,6	0,39	%
Correction for programmed idle speed increase					
IP_ISAPWM_FAC_N_SP_IS_ASA_TCO	6	0...FFH	0...0,996	1/256	-
TCO-correction factor for programmed idle speed increase					

Proprietary data, company confidential. All rights reserved. Contine a titre de secret d'entreprise. Tous droits réservés. Comunicado como segredo empresarial. Reservados todos os direitos. Confidado como secreto industrial. Nos reservamos todos los derechos.

Weitergabe sowie Vervielfältigung dieser Unterlage, Verwertung und Mitteilung ihres Inhalts nicht gestattet, soweit nicht ausdrücklich zugestanden. Zuwiderhandlungen verpflichten zu Schadensersatz. Alle Rechte vorbehalten, insbesondere für den Fall der Patenterteilung oder GM-Entragung.

1.13 Electrical load correction (ISAPWM_EL_LOAD, ISAPWM_EL_LOAD_TRA)

Output data:

Name	Mode	Hex. limits	Phys. limits	Resol.	Unit
ISAPWM_EL_LOAD	V	0...FFH	0...24,902	0,098	%
Idle charge - actuator opening correction for electrical load.					
ISAPWM_EL_LOAD_TRA	V	80...7FH	-12,5...12,402	0,098	%
Idle charge - actuator opening correction when LV_EL_LOAD is changing.					

Input data:

LV_EL_LOAD			
------------	--	--	--

FUNCTION DESCRIPTION:

General information:

The target is to correct the additionnal load on the engine when an electric load is active (head lamps, rear window defrost or brake light).

When one of this electric load is switched on, an additional duty cycle is applied in order to ensure a rapid intake pipe filling. This is performed by the ISAPWM_EL_LOAD_TRA term.

The application recurrence is **40 msec**.

Application conditions:

Available for all engine operating states.

Formula section:

1. ISAPWM_EL_LOAD calculation:

If LV_EL_LOAD = 1
Then ISAPWM_EL_LOAD = C_ISAPWM_EL_LOAD
Else ISAPWM_EL_LOAD = 0

2. ISAPWM_EL_LOAD_TRA calculation:

If Transition LV_EL_LOAD : 0 -> 1
Then ISAPWM_EL_LOAD_TRA is set to C_ISAPWM_EL_LOAD_TRA_INC and reseted to 0 using change limitation C_ISAPWM_EL_LOAD_TRA_LGRD.

If Transition LV_EL_LOAD : 1 -> 0
Then ISAPWM_EL_LOAD_TRA is set to C_ISAPWM_EL_LOAD_TRA_DEC and reseted to 0 using change limitation C_ISAPWM_EL_LOAD_TRA_LGRD.

Editor: Müller O.	17-Dec-97	Idle Speed	HMC_V6
Version: a 153589 from 18.12.97		657765.49.07	
File: CHAP_8.DOC	650H0000	Sourcefile:07800Q01.00A	Page 58 / 60

Proprietary data, company confidential. All rights reserved. Contine a titre de secret d'entreprise. Tous droits réservés. Comunicado como segredo empresarial. Reservados todos os direitos. Confidado como secreto industrial. Nos reservamos todos los derechos.

Weitergabe sowie Vervielfältigung dieser Unterlage, Wertung und Mitteilung ihres Inhalts nicht gestattet, soweit nicht ausdrücklich zugestanden. Zuwiderhandlungen verpflichten zu Schadensersatz. Alle Rechte vorbehalten, insbesondere für den Fall der Patenterteilung oder GM-Entragung.

Proprietary data, company confidential. All rights reserved.
 Contient des informations confidentielles. Tous droits réservés.
 Comunicado como segredo empresarial. Reservados todos os direitos.
 Confidado como secreto industrial. Nos reservamos todos los derechos.

Weitergabe sowie Vervielfältigung dieser Unterlage, Verwertung und Mitteilung ihres Inhalts ist gestattet, soweit nicht ausdrücklich zugestanden. Zuwiderhandlungen verpflichten zu Schadensersatz. Alle Rechte vorbehalten, insbesondere für den Fall der Patenterteilung oder GM-Entragung.

Calibration data:

Name	Dim	Hex. limits	Phys. limits	Resol.	Unit
C_ISAPWM_EL_LOAD	1	0...FFH	0...24,902	0,098	%
Idle charge actuator correction with electrical load (LV_EL_LOAD = 1)					
C_ISAPWM_EL_LOAD_TRA_INC	1	80...7FH	-12,5...12,402	0,098	%
Idle charge actuator correction with LV_EL_LOAD transition 0->1					
C_ISAPWM_EL_LOAD_TRA_DEC	1	80...7FH	-12,5...12,402	0,098	%
Idle charge actuator correction with LV_EL_LOAD transition 1->0					
C_ISAPWM_EL_LOAD_TRA_LGRD	1	0...7FH	0...12,402	0,098	%
ISAPWM_EL_LOAD_TRA reset change limitation					

Editor: Müller O.	17-Dec-97	Idle Speed	HMC_V6
Version: a 153589 from 18.12.97		657765.49.07	
File: CHAP_8.DOC	650H0000	Sourcefile:07800Q01.00A	Page 59 / 60

1.14 Automatic gearbox converter load correction

Output data:

Name	Mode	Hex. limits	Phys. limits	Resol.	Unit
ISAPWM_LOAD_AT_FAC	v	0...FFH	0...1	1/256	-
Correction factor for ISAPWM versus AT-load and TCO					
LOAD_AT	v	0...FFH	0...1	1/256	-
Torque converter load					
N_CONV	v	0...FFH	0...8160	1	rpm
Speed of the torque converter turbine.					

Input data:

N	LV_DRI_ISAPWM	ISAPWM_TCO_DRI_ACIN	TCO
---	---------------	---------------------	-----

FUNCTION DESCRIPTION:

General information:

To improve deceleration and to increase the vacuum in the surge tank during deceleration the ISA is corrected versus the load of the torque converter of the automatic gearbox. This load is calculated by the ratio between turbine speed of the torque converter and the engine speed. The turbine speed of the converter N_CONV is sent via CAN by the TCU. With TCO and LOAD_AT as input values a factor ISAPWM_LOAD_AT_FAC is calculated.
 If N < NC_ISAPWM_N_MAX, the application recurrence is 10 ms otherwise 40 ms.

Formula section:

$$LOAD_AT = N_CONV / N$$

In case of an error at the converter speed acquisition the TCU sends the identifier FFFFH via the CAN. Then the ISAPWM_LOAD_AT_FAC is set to 1

Application conditions:

IF LV_DRI_ISAPWM = 1
 Then ISAPWM_LOAD_AT_FAC = IP_ISAPWM_LOAD_AT_FAC__LOAD_AT__TCO
 Else ISAPWM_LOAD_AT_FAC = 1

Calibration data:

Name	Dim	Hex. limits	Phys. limits	Resol.	Unit
IP_ISAPWM_LOAD_AT_FAC__LOAD_AT__TCO	6x6	0...FFH	0...1	1/256	-
Automatic gearbox converter load correction factor					

Proprietary data, company confidential. All rights reserved. Contient des informations confidentielles. Tous droits réservés. Comunicado como segredo empresarial. Reservados todos os direitos. Confidado como secreto industrial. Nos reservamos todos los derechos.

Weitergabe sowie Vervielfältigung dieser Unterlage, Verwertung und Mitteilung ihres Inhalts ist gestattet, soweit nicht ausdrücklich zugestanden. Zuwiderhandlungen verpflichten zu Schadenersatz. Alle Rechte vorbehalten, insbesondere für den Fall der Patenterteilung oder GM-Entragung.

Document: **Auxiliary functions**

Project: **Engine Management System**
HMC_V6

Version: a

Date: 17-Dec-97

Number of pages: 120

Revision Code-No.: 153589 from 18.12.97

Construction protocol-No.:

Software version: 650H0000

	Name	Department	Phone	Date	Sign
Author	Müller O.	AT PT SI TSA 11	3211	09.12.97	
1. Check	Pioch O.	AT PT SI TSA 11	3212	09.12.97	
2. Check	Gessner S.	AT PT SI TSA 11	5398	09.12.97	
Responsible	Brückner D.	AT PT SI TSA 16	4279	09.12.97	

Version list

Proprietary data, company confidential. All rights reserved. Contine a titre de secret d'entreprise. Tous droits réservés. Comunicado como segredo empresarial. Reservados todos os direitos. Confidado como secreto industrial. Nos reservamos todos los derechos.

Weitergabe sowie Vervielfältigung dieser Unterlage, Wertung und Mitteilung ihres Inhalts nicht gestattet, soweit nicht ausdrücklich zugestanden. Zuwiderhandlungen verpflichten zu Schadensersatz. Alle Rechte vorbehalten, insbesondere für den Fall der Patenterteilung oder GM-Eintragung

Version	Date	Author	Comment, Description

Editor:	Müller O.	17-Dec-97	Auxiliary functions	HMC_V6
Version:	a 153589 from 18.12.97		657765.49.08	
File:	CHAP_9.DOC	650H0000		Page 2 / 120

Table of contents

Page

1	Torque reduction for automatic gearshift	18
2	Air condition compressor control	20
3	Variable intake manifold control	23
4	Evaporative emission control	27
4.1	General	27
4.2	Evaporative emission control valve duty cycle (CPPWM_CPS)	29
4.3	Evaporative emission control in steady operation (CPPWM)	30
4.4	Evaporative emission control state STB_CP operation	30
4.5	Evaporative emission control state MIN operation	31
4.6	Evaporative emission control state NORMAL operation	33
4.7	Evaporative emission control duration (T_CP)	35
4.8	Evaporative emission control in transient operation (FAC_CP)	37
4.8.1	Evaporative emission control mode : RAMP mode	37
4.9	Evaporative emission control mode : LEARNING mode	41
4.10	Injection time correction with evaporative emission control (LAM_TRA)	46
4.11	Influence of the evaporative emission control on lambda adaptation	52
5	Cooling and condenser fans control	53
6	Engine speed limitation	64
7	Vehicle speed limitation	69
8	Traction Control	71
8.1	Interface Description	71
8.1.1	General information	71
8.1.2	CAN Communication Signals	72
8.1.2.1	EMS Input Signals from the CAN	72
8.1.2.2	EMS Output Signals to the CAN	73
8.1.3	Status of Torque Intervention (STATE_TQ_INTV)	74
8.2	Internal auxiliary quantities	76
8.2.1	Relative torque reduction by misfire detection (TQR_REL_SCC_MIS)	76
8.2.2	Actual performed relative torque reduction by fuel cut-off (TQR_REL_SCC_AV)	77
8.2.3	Maximum relative torque reduction by spark retard (TQR_REL_MAX_IGA_N_MAF)	78
8.2.4	Actual relative torque reduction by spark retard (TQR_REL_IGA_AV)	79
8.3	Torque model	81
8.3.1	Standard torque (TQ_STND)	81
8.3.2	Frictional torque (TQFR)	81
8.3.3	Indicated engine torque (TQI)	83
8.3.3.1	Lambda influence weighted by ignition angle	84
8.3.3.2	Influence of ignition angle	85
8.3.3.2.1	Reference ignition angle (IGA_REF_TQR)	85
8.3.3.2.2	Relative Torque Reduction by EMS internal Spark Retard (TQR_REL_IGA_EMS)	86
8.3.3.3	Relative Torque Reduction by EMS internal Fuel Cut-Off (TQR_REL_SCC_EMS)	87

Editor:	Müller O.	17-Dec-97	Auxiliary functions	HMC_V6
Version:	a 153589 from 18.12.97		657765.49.08	
File:	CHAP_9.DOC	650H0000		Page 3 / 120

Proprietary data, company confidential. All rights reserved.
 Contine a titre de secret d'entreprise. Tous droits réservés.
 Comunicado como segredo empresarial. Reservados todos os direitos.
 Confidado como secreto industrial. Nos reservamos todos los derechos.

Weitergabe sowie Vervielfältigung dieser Unterlage, Verwertung und Mitteilung ihres Inhalts nicht gestattet, soweit nicht ausdrücklich zugestanden. Zuwiderhandlungen verpflichten zu Schadenersatz. Alle Rechte vorbehalten, insbesondere für den Fall der Patenterteilung oder GM-Entragung.

Proprietary data, company confidential. All rights reserved.
 Contine a titre de secret d'entreprise. Tous droits réservés.
 Comunicado como secreto empresarial. Reservados todos os direitos.
 Confidado como secreto industrial. Nos reservamos todos los derechos.

Weitergabe sowie Vervielfältigung dieser Unterlage, Verwertung und Mitteilung ihres Inhalts nicht gestattet, soweit nicht ausdrücklich zugestanden. Zuwiderhandlungen verpflichten zu Schadenersatz. Alle Rechte vorbehalten, insbesondere für den Fall der Patenterteilung oder GM-Enttragung

8.4	Exhaust gas temperature model	88
8.4.1	Stationary exhaust gas temperature (TEG_STAT)	89
8.4.2	Dynamic Exhaust Gas Temperature (TEG_MMV_SUB)	90
8.5	Torque Intervention for ASR and Gear Shift	91
8.5.1	Overview of the possible torque interventions	93
8.5.2	Conditions for ASR- and GS-intervention	94
8.5.3	Torque Reduction Intervention	95
8.5.3.1	Relative Nominal Torque Reduction for ASR (TQR_REL_ASR_NV)	95
8.5.3.2	Relative Nominal Torque Reduction for GS (TQR_REL_GS_NV)	96
8.5.3.3	Determination of the Torque Reduction Amount	96
8.5.3.4	Selection of the Torque Reduction Mode	97
8.5.3.5	Exhaust gas temperature logic	98
8.5.3.6	Ignition Angle Adjustment (IGA_ADJ) Mode	99
8.5.3.7	Cylinder Shut-Off (SCC) Mode	100
8.5.3.8	Torque Reduction by Single Cylinder Shut-Off (SCC) and Ignition Angle Adjustment (IGA_ADJ) Mode	102
8.5.3.9	Minimum Torque Reduction Pattern	105
8.5.3.10	Hysteresis between Cylinder Shut-Off and Ignition Angle Adjustment	106
8.5.4	Torque Intervention by the Application System	107
8.6	Execution of a Torque Intervention	108
8.6.1	Ignition Angle Retard Adjustment (IGA_ADJ_TQR)	108
8.6.2	Selection of Cylinder Shut-Off Patterns	109
8.7	Auxiliary functions	109
8.7.1	ASR Warm-up	109
8.7.2	Leaning Function for Cylinder Shut-Off outside the Warm-Up Mode	110
8.7.3	Inhibition of Lambda closed loop control	111
8.7.4	Inhibition of EGR during Cylinder Shut-Off	112
8.7.5	Cylinder-specific fuel mixture enrichment on restarting fuel-feed	113
8.7.5.1	Calculation of the Wall-Applied Fuel Film Removal	114
8.7.5.2	Additional Injection Quantity for Re-Activation of the Cylinder	114
8.7.5.3	Case studies	115
8.8	Torque during an torque intervention (TQI_INTV)	116
8.9	ASR Statistics Counters	117
8.9.1	Cylinder Shut-Off Time Counter T_SCC_S and T_SCC_L	117
8.9.2	Event Frequency Counter - Intervention Statistics ASR_STAT_0...15	118
8	.10 Torque Reduction Emergency Operation	119
9	Fuel pump relay control	120

Editor:	Müller O.	17-Dec-97	Auxiliary functions	HMC_V6
Version:	a 153589 from 18.12.97		657765.49.08	
File:	CHAP_9.DOC	650H0000		Page 4 / 120

Index

Page

A

ACK_TCS_CAN	
def.....	71
ASR_STAT_0...15	
def.....	116

C

C_ACCIN_DLY_1	
def.....	22
C_ACCIN_DLY_4	
def.....	22
C_ACCIN_DLY_5	
def.....	22
C_ACCIN_DLY_6	
def.....	22
C_ACCIN_VS_MAX	
def.....	22
C_COR_FAC_INC_CP	
def.....	40
C_CPPWM_AD_MAX	
def.....	45
C_CPPWM_AD_MIN	
def.....	45
C_CPPWM_AS	
def.....	34
C_CPPWM_CLOSE	
def.....	40
C_FAC_CP_LD_MAX	
def.....	45
C_FAC_MIN_P_CP	
def.....	45
C_IGA_LGRD_TQR	
def.....	107
C_LAM_CYCNR	
def.....	70
C_LAM_DIF_MAX_TRA	
def.....	45
use.....	46
C_LAM_MAX_CYCNR	
def.....	34
C_LAM_MIN_CP	
def.....	45
C_LAM_MV_BEG_MAX	
def.....	36
C_LAM_MV_CRLC	
def.....	51
C_LAM_MV_DIF_COR_MAX_CP	
def.....	45
use.....	46
C_LAM_MV_DIF_MAX_1_CP	
def.....	45
C_LAM_MV_MMV_DIF_CP	

Proprietary data, company confidential. All rights reserved.
 Contit a titre de secret d'entreprise. Tous droits réservés.
 Comunicado como segredo empresarial. Reservados todos os direitos.
 Confidado como secreto industrial. Nos reservamos todos los derechos.

Weitergabe sowie Vervielfältigung dieser Unterlage, Verwertung und Mitteilung ihres Inhalts nicht gestattet, soweit nicht ausdrücklich zugestanden. Zuwiderhandlungen verpflichten zu Schadensersatz. Alle Rechte vorbehalten, insbesondere für den Fall der Patenterteilung oder GM-Entragung

Editor: Müller O.	17-Dec-97	Auxiliary functions	HMC_V6
Version: a 153589 from 18.12.97		657765.49.08	
File: CHAP_9.DOC	650H0000		Page 5 / 120

Proprietary data, company confidential. All rights reserved.
 Contine a titre de secret d'entreprise. Tous droits réservés.
 Comunicado como segredo empresarial. Reservados todos os direitos.
 Confidado como secreto industrial. Nos reservamos todos los derechos.

Weitergabe sowie Vervielfältigung dieser Unterlage, Verwertung und Mitteilung ihres Inhalts nicht gestattet, soweit nicht ausdrücklich zugestanden. Zuwiderhandlungen verpflichten zu Schadensersatz. Alle Rechte vorbehalten, insbesondere für den Fall der Patenterteilung oder GM-Enttragung

def.....	51
C_LAM_TRA_STATE_MIN	
def.....	45
use.....	46
C_LGRD_TQR_DEC_DIAG	
def.....	118
C_MAF_FAC_ALTI_IS_CP	
def.....	34
C_MAF_LAM_BOL_TRA	
def.....	51
C_MAF_LAM_TOL_TRA	
def.....	51
C_N_ACCIN_OFF	
def.....	22
C_N_ADD_ASR	
def.....	94
C_N_FCUT	
def.....	68
C_N_HYS_VIM	
def.....	26
C_N_MAX	
def.....	68
C_N_MAX_CRK_DIAG	
def.....	68
C_N_MAX_FCUT	
def.....	68
C_N_MAX_HYS	
def.....	68
C_N_MAX_HYS_MAX	
def.....	68
C_N_MAX_IGA_TQR	
def.....	98
C_N_MAX_MAX	
def.....	68
C_N_MAX_TPS_DIAG	
def.....	68
C_N_MAX_TPS_ISAPWM_DIAG	
def.....	68
C_N_MAX_VS_DIAG	
def.....	68
C_SUM_STATE_MAX	
def.....	45
C_T_1_CP	
def.....	36
C_T_2_CP	
def.....	36
C_T_DLY_DIAG_TQR	
def.....	118
C_T_DLY_EGR_TQR	
def.....	111
C_T_DLY_LAM_TQR	
def.....	110
C_T_EFP	
def.....	119
C_T_GS_DLY_DIAG	
def.....	19, 94
C_T_LAM_MAX_STATE	

Editor: Müller O.	17-Dec-97	Auxiliary functions	HMC_V6
Version: a 153589 from 18.12.97		657765.49.08	
File: CHAP_9.DOC	650H0000		Page 6 / 120

def.....	45
C_T_N_MAX_FCUT	
def.....	68
C_T_OFF_CFA_ST	
def.....	62
C_T_RTD_DEC_CFA	
def.....	62
C_T_RTD_INC_0_CFA	
def.....	62
C_T_RTD_INC_1_CFA	
def.....	62
C_T_VIM_FAC	
def.....	26
C_TCO_1_CFA	
def.....	62
C_TCO_2_CFA	
def.....	62
C_TCO_3_CFA	
def.....	62
C_TCO_4_CFA	
def.....	62
C_TCO_5_CFA	
def.....	62
use.....	20
C_TCO_HYS_1_CFA	
def.....	62
C_TCO_HYS_2_CFA	
def.....	62
C_TCO_HYS_3_CFA	
def.....	62
C_TCO_HYS_4_CFA	
def.....	62
use.....	20
C_TCO_MIN_CP	
def.....	34
C_TCO_MIN_SCC	
def.....	98
C_TCO_N_MAX_FCUT	
def.....	68
C_TCO_ON_CFA_ES	
def.....	62
C_TEG_FAC_IGA	
def.....	103
C_TEG_MAX	
def.....	98
use.....	104
C_TEG_THD_1	
def.....	98
C_TEG_THD_2	
def.....	98
C_TI_T_AD_1	
def.....	36
C_TI_VS_MAX_COR	
use.....	69
C_TPS_GRD_ACCIN_OFF	
def.....	22
C_TPS_HYS_VIM	

Editor: Müller O.	17-Dec-97	Auxiliary functions	HMC_V6
Version: a 153589 from 18.12.97		657765.49.08	
File: CHAP_9.DOC	650H0000		Page 7 / 120

def.....	26
C_TQ_INTV_REL_ERR_MAX	
def.....	75
C_TQ_STND	
def.....	81
C_TQFR_ADD_ACC_H	
def.....	82
C_TQFR_ADD_ACC_L	
def.....	82
C_TQR_AS	
def.....	106
C_TQR_HYS	
def.....	105
C_VB_MIN_VIM	
def.....	26
C_VS_ACCIN_OFF	
def.....	22
C_VS_MAX_CYCNR	
def.....	70
C_VS_MAX_HYS	
def.....	70
C_VS_MIN_VIM	
def.....	26
CONF_CP	
use.....	31
CONF_LAM	
use.....	31
CPPWM	
def.....	30
use.....	29, 30, 37, 41, 46, 52
CPPWM_CPS.....	29
CRLC_TEG	
def.....	88
F	
FAC_BEG_CP	
def.....	37
use.....	41
FAC_CP	
def.....	37
use.....	30, 33, 41
FAC_IGA_TQR	
def.....	79, 86
use.....	85
FAC_TQR	
def.....	107
use.....	85
I	
ID_CRLC_TEG_DEC__MAF_KGH	
def.....	90
ID_CRLC_TEG_INC__MAF_KGH	
def.....	90
ID_N_MAX_CYCNR__VS	
def.....	68
ID_ON_CFA_ES__TCO__TIA	
def.....	62

Editor: Müller O.	17-Dec-97	Auxiliary functions	HMC_V6
Version: a 153589 from 18.12.97		657765.49.08	
File: CHAP_9.DOC	650H0000		Page 8 / 120

Proprietary data, company confidential. All rights reserved.
 Contient des informations confidentielles. Tous droits réservés.
 Comunicado como secreto empresarial. Reservados todos os direitos.
 Confidado como secreto industrial. Nos reservamos todos los derechos.

Weitergabe sowie Vervielfältigung dieser Unterlage, Verwertung und Mitteilung ihres Inhalts nicht gestattet, soweit nicht ausdrücklich zugestanden. Zuwiderhandlungen verpflichten zu Schadensersatz. Alle Rechte vorbehalten, insbesondere für den Fall der Patenterteilung oder GM-Enttragung

ID_PAT_INH_IV_MIN__LAM_SUB__TEG_DIF	
def.....	103
use.....	100
ID_PAT_INH_IV_TQR__TQR_REL_NV	
def.....	101
use.....	102
ID_TEG_FAC_SCC__PAT_INH_IV	
def.....	90
ID_TI_DEC_WF__N_32	
def.....	114
ID_TI_INC_WF__N_32	
def.....	114
ID_TI_N_POS_RG__N_32	
def.....	114
ID_TI_SCC__MAF_KGH	
def.....	109
ID_TI_TCO_NEG_WF__TCO	
def.....	114
ID_TI_TCO_POS_WF__TCO	
def.....	114
ID_TQR_REL_SCC__PAT_INH_IV	
def.....	103
use.....	87
ID_TQR_REL_SCC__PAT_INH_IV_TQR	
def.....	101
ID_VIM__N_32_VIM__TPS_VIM	
def.....	26
IGA_ADJ_TQR	
def.....	107
IGA_BAS	
use.....	85
IGA_CYL_[CYL]	
use.....	86
IGA_DIF_REF_AV	
def.....	79
use.....	83
IGA_DIF_REF_EMS	
def.....	86
IGA_EGR	
use.....	85
IGA_IGC_CYL_[CYL]	
use.....	79
IGA_OUT_TQR	
def.....	107
IGA_OUT_TQR_NV	
def.....	107
IGA_REF_TQR	
def.....	85
use.....	79, 86, 107
IP_ACCIN_DLY_2__N_32	
def.....	22
IP_ACCIN_DLY_3__N_32	
def.....	22
IP_CPPWM_ALTI_COR_MAX__N_32__MAF_ALTI_COR	
def.....	34
use.....	46
IP_CPPWM_ALTI_COR_MIN__N_32__MAF_ALTI_COR	

Editor: Müller O.	17-Dec-97	Auxiliary functions	HMC_V6
Version: a 153589 from 18.12.97		657765.49.08	
File: CHAP_9.DOC	650H0000		Page 9 / 120

def.....	34
IP_CPPWM_CPS_CPPWM	
def.....	29
IP_CPPWM_CPS_VB_ADD_VB	
def.....	29
IP_CPPWM_MAX_N_MAF	
use.....	37, 41, 46
IP_CPPWM_MAX_N_32_MAF	
def.....	34
IP_CPPWM_MIN_N_MAF	
use.....	37, 41, 46
IP_CPPWM_MIN_N_32_MAF	
def.....	34
IP_FAC_DEC_CP_MAF_KGH	
def.....	40
IP_FAC_FAC_DEC	
def.....	40
IP_FAC_IGA_TQR_FAC_TQR	
def.....	85
use.....	107
IP_FAC_INC_CP_MAF_KGH	
def.....	40
IP_FAC_LAM_TQI_LAM_SUB_IGA_DIF_REF_AV	
def.....	83
use.....	18, 83, 95, 96, 115
IP_FAC_TQR_FAC_IGA_TQR	
def.....	80, 85
use.....	79, 86
IP_FAC_VS_TEG_VS	
def.....	90
IP_IGA_DIF_MAX_TQR_N_32_MAF	
def.....	80, 107
use.....	86
IP_LAM_CP_N_32_MAF	
def.....	51
IP_LAM_CP_N_32_MAF_ALTI_COR	
def.....	51
use.....	41
IP_LAM_DIF_MAX_CP	
def.....	45
IP_LAM_TRA_LGRD_MAF_KGH	
def.....	51
IP_MAF_ALTI_COR_MAX_CPS_N_32	
def.....	34
IP_N_MAX_ISAPWM_DIAG_TPS	
def.....	68
IP_T_VIM_VB	
def.....	26
IP_TEG_N_32_MAF	
def.....	90
IP_TEG_ADD_IGA_POW_DIF	
def.....	90
IP_TEG_FAC_LAM_LAM_SUB	
def.....	90
IP_TEG_STAT_ADD_SCC_MAF_KGH	
def.....	90
IP_TI_TCO_WUP_ASR_TCO_TCO_ST	

Editor: Müller O.	17-Dec-97	Auxiliary functions	HMC_V6
Version: a 153589 from 18.12.97		657765.49.08	
File: CHAP_9.DOC	650H0000		Page 10 / 120

def.....	109
IP_TQFR__N_32__MAF	
def.....	82
IP_TQFR_ADD_TCO__TCO	
def.....	82
IP_TQI__N_32__MAF	
def.....	83
use.....	18, 95, 96, 115
IP_TQR_REL_MAX_IGA__N_32__MAF	
def.....	78
L	
L_INH_IV_[CYL]	
use.....	30
LAM_MV_BEG.....	41
use.....	35, 46
LAM_MV_DIF_COR_CP.....	46
use.....	41
LAM_MV_DIF_CP.....	40, 41
use.....	46
LAM_MV_DIF_CP_LD.....	41
LAM_MV_i.....	46
use.....	41
LAM_MV_MMV.....	46
LAM_MV_MMV_DIF.....	46
LAM_SUB.....	84
use.....	83, 88
LAM_TRA.....	46
use.....	30, 41
LV_ACCIN	
use.....	20, 53
LV_ACIN	
use.....	20, 53
LV_ACK_TCS	
use.....	71
LV_ASR_REQ	
def.....	71
use.....	74, 91
LV_AUTH_LAM_1_AD_LEARN_CP	
def.....	52
LV_AUTH_LAM_2_AD_LEARN_CP	
def.....	52
LV_AUTH_LAM_AD_CP	
def.....	52
use.....	30, 35
LV_AUTH_LAM_i_AD_LEARN_CP	
use.....	41
LV_CDN_ASR	
def.....	91
use.....	95
LV_CDN_GS	
def.....	91
use.....	96
LV_CPS_ERR	
use.....	30, 91
LV_CRK_ERR	
use.....	64

Editor: Müller O.	17-Dec-97	Auxiliary functions	HMC_V6
Version: a 153589 from 18.12.97		657765.49.08	
File: CHAP_9.DOC	650H0000		Page 11 / 120

Proprietary data, company confidential. All rights reserved.
 Contient des informations confidentielles. Tous droits réservés.
 Comunicado como segredo empresarial. Reservados todos os direitos.
 Confidado como secreto industrial. Nos reservamos todos los derechos.

Weitergabe sowie Vervielfältigung dieser Unterlage, Verwertung und Mitteilung ihres Inhalts nicht gestattet, soweit nicht ausdrücklich zugestanden. Zuwiderhandlungen verpflichten zu Schadensersatz. Alle Rechte vorbehalten, insbesondere für den Fall der Patenterteilung oder GM-Enttragung

LV_CRK_ERR_LIH	
use.....	64
LV_CT	
use.....	20, 64
LV_DRI	
use.....	18, 64, 91
LV_DUR_IGC_[CYL]_ERR	
use.....	31
LV_ENG_RUN_IS_PL	
use.....	23
LV_ES	
use.....	18, 23, 27, 53, 79, 81, 83, 84, 86, 88, 91, 115, 119
LV_FL	
use.....	20, 41
LV_GS_REQ	
def.....	71
use.....	18, 74
LV_IGA_ADJ_MOD	
def.....	97
use.....	99, 100, 102
LV_IGA_ADJ_TQR	
def.....	99, 100, 102
LV_IGA_AST	
use.....	27
LV_IGK	
use.....	53, 119
LV_IS	
use.....	18, 20, 30, 35, 53, 91
LV_ISA_i_ERR	
use.....	31, 64
LV_ISA_MECHA_ERR	
use.....	64
LV_IV_[CYL]_ERR	
use.....	31, 91
LV_LAM_ACT_i	
use.....	46
LV_LAM_LIM_CDN	
use.....	37
LV_LEARN_CP	
def.....	41
use.....	52
LV_LS_i	
use.....	46
LV_LSCL_1	
use.....	69
LV_LSCL_2	
use.....	69
LV_LSCL_i	
use.....	31
LV_LSH_UP_i_ERR	
use.....	31
LV_MAF_ERR	
use.....	31, 64, 91
LV_MAF_PLAUS_ERR	
use.....	31, 64
LV_MIN_PHA_CP	
def.....	31

Editor: Müller O.	17-Dec-97	Auxiliary functions	HMC_V6
Version: a 153589 from 18.12.97		657765.49.08	
File: CHAP_9.DOC	650H0000		Page 12 / 120

use.....	52
LV_N_MAF_DYW_i	
use.....	46
LV_N_MAX	
def.....	64
LV_N_MAX_FCUT	
def.....	64
LV_NORMAL_PHA_CP	
def.....	33
use.....	52
LV_OPL_VS_MAX	
def.....	69
LV_PL	
use.....	20, 35
LV_PRS_ACC	
use.....	53, 81
LV_PUC	
use.....	41, 83
LV_RLY_ACCOUT	
def.....	20
use.....	53, 81
LV_RLY_ACCOUT_CTRL	
def.....	20
LV_RLY_FAN_H	
def.....	53
LV_RLY_FAN_L	
def.....	53
LV_SCC_EGR_TQR	
def.....	111
LV_SCC_LAM_TQR	
def.....	110
LV_SCC_MOD	
def.....	97
use.....	74, 99, 100, 102
LV_SCC_TQR	
def.....	99, 100, 102
use.....	108, 109, 110, 111
LV_SLOP_CP	
def.....	37
use.....	52
LV_SOV_ERR	
use.....	30
LV_SOV_MECHA_ERR	
use.....	30
LV_ST	
use.....	18, 20, 23, 27, 35, 91
LV_STATE_A_MIS	
use.....	31
LV_STB_PHA_CP	
def.....	30
use.....	29, 52
LV_TCO_ERR	
use.....	31, 53, 64
LV_TCO_PLAUS_ERR	
use.....	31
LV_TEG_MAX	
def.....	97

Editor: Müller O.	17-Dec-97	Auxiliary functions	HMC_V6
Version: a 153589 from 18.12.97		657765.49.08	
File: CHAP_9.DOC	650H0000		Page 13 / 120

Proprietary data, company confidential. All rights reserved.
 Contient des informations confidentielles de l'entreprise. Tous droits réservés.
 Comunicado como segredo empresarial. Reservados todos os direitos.
 Confidado como secreto industrial. Nos reservamos todos los derechos.

Weitergabe sowie Vervielfältigung dieser Unterlage, Verwertung und Mitteilung ihres Inhalts ist gestattet, soweit nicht ausdrücklich zugestanden. Zuwiderhandlungen verpflichten zu Schadensersatz. Alle Rechte vorbehalten, insbesondere für den Fall der Patenterteilung oder GM-Enttragung

LV_TI_AST	
use.....	27
LV_TIA_ERR	
use.....	31
LV_TPS_ERR	
use.....	31, 64
LV_TPS_PLAUS_ERR	
use.....	31, 64
LV_VIM	
def.....	23
LV_VIM_CTRL	
def.....	23
LV_VLS_LIM_i_ERR	
use.....	31
LV_VLS_UP_i_ERR	
use.....	31
LV_VS_ERR	
use.....	64
LV_VS_MAX	
def.....	69
M	
MAF	
use.....	46, 78, 79, 81, 83, 88
MAF_ALTI_COR	
use.....	31, 33, 41, 46
MAF_FAC_ALTI_MMV	
use.....	30
MAF_KGH	
use.....	46, 88, 109
MIS_NR_OFF_IV	
use.....	76
N	
N	
use.....	88, 91, 102
N_32	
use.....	20, 23, 41, 46, 64, 69, 78, 79, 81, 83, 88, 112
N_32_VIM	
def.....	23
N_MAX_MAX	
def.....	64
N_MAX_THD	
def.....	64
N_SP_IS	
use.....	91
NC_CYL_NO	
use.....	79, 86
NC_INI_INH_SWI_IV_SHIFT_NR	
use.....	64, 69
P	
PAT_INH_IV	
use.....	30, 88
PAT_INH_IV_MAX_N_VS	
def.....	87
PAT_INH_IV_N_MAX	
def.....	64

Editor: Müller O.	17-Dec-97	Auxiliary functions	HMC_V6
Version: a 153589 from 18.12.97		657765.49.08	
File: CHAP_9.DOC	650H0000		Page 14 / 120

Proprietary data, company confidential. All rights reserved.
 Contient des données confidentielles de la société. Tous droits réservés.
 Comunicado como segredo empresarial. Reservados todos os direitos.
 Confidado como secreto industrial. Nos reservamos todos los derechos.

Weitergabe sowie Vervielfältigung dieser Unterlage, Verwertung und Mitteilung ihres Inhalts nicht gestattet, soweit nicht ausdrücklich zugestanden. Zuwiderhandlungen verpflichten zu Schadenersatz. Alle Rechte vorbehalten, insbesondere für den Fall der Patenterteilung oder GM-Entragung.

use.....	87
PAT_INH_IV_TQR	
def.....	99, 100, 102
PAT_INH_IV_VS_MAX	
def.....	69
use.....	87
POW_DIF	
def.....	88
S	
STATE_CFA	
def.....	53
STATE_CFA_1	
def.....	53
STATE_CFA_IS	
def.....	53
STATE_TQ_INTV	
def.....	74
use.....	71
SWI_GS_CAN	
use.....	71
T	
T_ASR_CTR	
def.....	116
T_CP	
def.....	35
use.....	41
T_DLY_DIAG_TQR	
def.....	118
T_DLY_EGR_TQR	
def.....	111
T_DLY_LAM_TQR	
def.....	110
T_GS_DLY_DIAG	
def.....	18, 91
T_SCC_L	
def.....	116
T_SCC_S	
def.....	116
T_VIM	
def.....	23
TCO	
use.....	20, 30, 53, 64, 81, 88, 97, 108, 112
TCO_ST	
use.....	108
TCS_REQ_CAN	
use.....	71
TEG_DIF	
def.....	104
use.....	102
TEG_MMV_SUB	
def.....	88
use.....	97, 104
TEG_STAT	
def.....	88
TI_AD_ADD_MMV	

Editor: Müller O.	17-Dec-97	Auxiliary functions	HMC_V6
Version: a 153589 from 18.12.97		657765.49.08	
File: CHAP_9.DOC	650H0000		Page 15 / 120

use.....	84
TI_AD_FAC_MMV	
use.....	84
TI_ADD_REAC_SCC_[CYL]	
def.....	112
TI_DIF_WF_[CYL]	
def.....	112
TI_LAM	
use.....	46
TI_LAM_i	
use.....	41
TI_MV	
use.....	84
TI_WUP_COR	
def.....	108
TIA	
use.....	53
TIB	
use.....	84, 112
TPS	
use.....	23, 64
TPS_GRD	
use.....	20
TPS_VIM	
def.....	23
TQ_COR_STAT_CAN	
def.....	71
TQ_INTV_REL_ERR	
def.....	74
TQ_STND	
def.....	81
use.....	18, 71, 74, 91
TQ_STND_CAN	
def.....	71
TQFR	
def.....	81
use.....	71
TQFR_CAN	
def.....	71
TQI	
def.....	83
use.....	18, 71, 88, 91, 102
TQI_ACOR_CAN	
def.....	71
TQI_ASR_REQ	
def.....	71
use.....	18, 74, 95
TQI_CAN	
def.....	71
TQI_GS_REQ	
def.....	71
use.....	18, 74, 96
TQI_INTV	
def.....	115
use.....	71, 74
TQI_TCS_CAN	
use.....	71, 91

Editor: Müller O.	17-Dec-97	Auxiliary functions	HMC_V6
Version: a 153589 from 18.12.97		657765.49.08	
File: CHAP_9.DOC	650H0000		Page 16 / 120

Proprietary data, company confidential. All rights reserved.
 Contient des données confidentielles de l'entreprise. Tous droits réservés.
 Comunicado como secreto empresarial. Reservados todos los derechos.
 Confiado como secreto industrial. Nos reservamos todos los derechos.

Weitergabe sowie Vervielfältigung dieser Unterlage, Wertung und Mitteilung ihres Inhalts nicht gestattet, soweit nicht ausdrücklich zugestanden. Zuwiderhandlungen verpflichten zu Schadensersatz. Alle Rechte vorbehalten, insbesondere für den Fall der Patenterteilung oder GM-Enttragung.

TQI_TCU_CAN	
use.....	18, 71, 91
TQR_AS	
def.....	106
use.....	91
TQR_ASR_MAX	
def.....	116
TQR_REL_ASR_NV	
def.....	95
use.....	96, 116
TQR_REL_GS_NV	
def.....	96
use.....	96
TQR_REL_IGA_AV	
def.....	79
use.....	88, 115
TQR_REL_IGA_EMS	
def.....	86
use.....	83
TQR_REL_IGA_OUT	
def.....	91, 99, 100, 102
use.....	91, 107
TQR_REL_MAX_IGA_N_MAF	
def.....	78
use.....	79, 86, 97, 99, 102, 107
TQR_REL_MAX_IGA_TEG	
def.....	102
TQR_REL_NV	
def.....	96
use.....	97, 99, 102
TQR_REL_OUT	
def.....	91
TQR_REL_SCC_AV	
def.....	77
use.....	78, 115, 116
TQR_REL_SCC_EMS	
def.....	87
use.....	83
TQR_REL_SCC_MIS	
def.....	76
use.....	77, 87
TQR_REL_SCC_N_VS	
def.....	87
TQR_REL_SCC_OUT	
def.....	91, 99, 100, 102
use.....	77
V	
VB	
use.....	23, 29
VS	
use.....	20, 64, 69, 88
VS_MAX	
use.....	69
VS_STATE_CFA	
use.....	53

Editor: Müller O.	17-Dec-97	Auxiliary functions	HMC_V6
Version: a 153589 from 18.12.97		657765.49.08	
File: CHAP_9.DOC	650H0000		Page 17 / 120

1 Torque reduction for automatic gearshift

Output data:

Name	Mode	Hex. limits	Phys. limits	Resol.	Unit
T_GS_DLY_DIAG	V	0...FFFFH	0...655.35	0.01	s
Diagnosis time during gearshift					

Input data:

TQI_GS_REQ	LV_GS_REQ	LV_ST	LV_ES
TQI	TQI_ASR_REQ	LV_DRI	TQ_STND
IP_TQI_N_32_MAF	IP_FAC_LAM_TQI_LAM_S UB_IGA_DIF_REF_AV	LV_IS	TQI_TCU_CAN

FUNCTION DESCRIPTION:

General information:

At a car with automatic transmission the engine torque during gearshift event is reduced by retarding of spark advance or, if this is not enough, by cylinder shut-off. The reduced torque is requested by the TCU. The apportionment of the torque reduction between spark retard and cylinder shut-off is done by the torque management control logic, which is described in the chapter „Traction Control - Torque Intervention“.

The gearshift respectively the duration of the torque reduction request is watched by a timer T_GS_DLY_DIAG. If the timer reaches the limit C_T_GS_DLY_DIAG, the torque reduction will be ramped to zero and not performed anymore during the current driving cycle.

Application recurrence: **10 ms**

Application conditions:

if LV_IS = 0 *(not idle speed)*
and LV_ES = 0 *(not engine stop)*
and LV_ST = 0 *(not engine start)*
and LV_DRI = 1 *(Drive or reverse gear selected)*
and TQI_GS_REQ < TQI *(actually torque reduction requested)*
and TQI_GS_REQ < TQI_ASR_REQ *(req. torque for GS below ASR-torque)*
and TQI_TCU_CAN < 100% (TQ_STND) *(GS requested torque below TQI)*
and T_GS_DLY_DIAG < C_T_GS_DLY_DIAG *(diagnosis time not exceeded)*
then LV_CDN_GS = 1 *(torque reduction is possible)*
else LV_CDN_GS = 0 *(no torque reduction possible)*

Editor: Müller O.	17-Dec-97	Auxiliary functions	HMC_V6
Version: a 153589 from 18.12.97		657765.49.08	
File: CHAP_9.DOC	650H0000	Sourcefile:07900201.00D	Page 18 / 120

Proprietary data, company confidential. All rights reserved.
 Contient des données confidentielles. Tous droits réservés.
 Comunicado como secreto empresarial. Reservados todos los derechos.
 Confidado como secreto industrial. Nos reservamos todos los derechos.

Weitergabe sowie Vervielfältigung dieser Unterlage, Verwertung und Mitteilung ihres Inhalts ist gestattet, soweit nicht ausdrücklich zugestanden. Zuwiderhandlungen verpflichten zu Schadensersatz. Alle Rechte vorbehalten, insbesondere für den Fall der Patenterteilung oder GM-Entragung.

Proprietary data, company confidential. All rights reserved.
 Contitue a titre de secret d'entreprise. Tous droits réservés.
 Comunicado como segredo empresarial. Reservados todos os direitos.
 Confidado como secreto industrial. Nos reservamos todos los derechos.

Weitergabe sowie Vervielfältigung dieser Unterlage, Verwertung und Mitteilung ihres Inhalts nicht gestattet, soweit nicht ausdrücklich zugestanden. Zuwiderhandlungen verpflichten zu Schadensersatz. Alle Rechte vorbehalten, insbesondere für den Fall der Patenterteilung oder GM-Eintragung.

Formula section :

The torque during gearshift TQR_REL_GS_NV is calculated from the torque reduction control logic as described in chapter „Traction Control - Torque Intervention“.

Calibration data:

Name	Dim	Hex. limits	Phys. limits	Resol.	Unit
C_T_GS_DLY_DIAG	INT	0..FFFFH	0..655.35	0.01	s
Diagnosis timer threshold for gearshift					

Editor: Müller O.	17-Dec-97	Auxiliary functions	HMC_V6
Version: a 153589 from 18.12.97		657765.49.08	
File: CHAP_9.DOC	650H0000	Sourcefile:07900201.00D	Page 19 / 120

2 Air condition compressor control

Output data:

Name	Mode	Hex. limits	Phys. limits	Resol.	Unit
LV_RLY_ACCOUT	V	0...01H	0...1	1	-
Boolean of air condition compressor relay (OFF / ON).					
LV_RLY_ACCOUT_CTRL	V	0...01H	0...1	1	-
Boolean to activate ISAPWM correction related to air condition compressor relay					

Input data:

LV_ACIN	LV_ACCIN	LV_ST	LV_FL
LV_PL	LV_IS	N_32	TCO
VS	C_TCO_5_CFA	C_TCO_HYS_4_CFA	LV_CT
TPS_GRD			

FUNCTION DESCRIPTION:

General information:

The air condition compressor relay LV_RLY_ACCOUT is controlled by the ECU. It is enabled and disabled versus LV_ACIN and LV_ACCIN information. In order to keep a stable engine speed when A/C compressor is activated or dis-activated, idle speed valve correction are triggered in advance with LV_RLY_ACCOUT_CTRL.

Remind : LV_ACIN : Air condition selected
 LV_ACCIN : Air condition requested

Application reccurency = **40 ms**

Application conditions:

* *Initialization :*

LV_RLY_ACCOUT and LV_RLY_ACCOUT_CTRL are set to 0 in the engine operating state engine stopped (LV_ES).

* *Activation (LV_RLY_ACCOUT = ON) :*

If corresponding "Variant Coding" dedicated
and engine operating states engine stopped (LV_ES) not active
and engine operating state start (LV_ST) not active
and air condition selected (LV_ACIN = ACIN)
and air condition requested (LV_ACCIN = ACCIN)
and LV_RLY_ACCOUT= OFF since more than C_ACCIN_DLY_5 seconds
and $TCO \leq C_TCO_5_CFA$
then LV_RLY_ACCOUT_CTRL is enabled immediately
 LV_RLY_ACCOUT is enabled after IP_ACCIN_DLY_2__N_32 seconds.

Editor: Müller O.	17-Dec-97	Auxiliary functions	HMC_V6
Version: a 153589 from 18.12.97		657765.49.08	
File: CHAP_9.DOC	650H0000	Sourcefile:07900301.00F	Page 20 / 120

Proprietary data, company confidential. All rights reserved. Contine a titre de secret d'entreprise. Tous droits réservés. Comunicado como segredo empresarial. Reservados todos os direitos. Confidado como secreto industrial. Nos reservamos todos los derechos.

Weitergabe sowie Vervielfältigung dieser Unterlage, Verwertung und Mitteilung ihres Inhalts nicht gestattet, soweit nicht ausdrücklich zugestanden. Zuwiderhandlungen verpflichten zu Schadenersatz. Alle Rechte vorbehalten, insbesondere für den Fall der Patenterteilung oder GM-Enttragung

*** Deactivation (LV_RLY_ACCOUT = OFF) :**

If one of the deactivation conditions are true, LV_RLY_ACCOUT and LV_RLY_ACCOUT_CTRL are disabled whatever the activation conditions are.

- 1 - **If** engine operating state start (LV_ST) active
then LV_RLY_ACCOUT_CTRL is disabled **during** C_ACCIN_DLY_4 seconds
 LV_RLY_ACCOUT is disabled **during** IP_ACCIN_DLY_2 + C_ACCIN_DLY_4

- 2 - **If** acceleration enrichment due to full load (LV_FL) active
and VS < C_ACCIN_VS_MAX
then LV_RLY_ACCOUT_CTRL and LV_RLY_ACCOUT are disabled immediately **during** C_ACCIN_DLY_1 seconds.

- 3 - **If** LV_ACCIN = 0 (-)
then LV_RLY_ACCOUT_CTRL is disabled immediately
 LV_RLY_ACCOUT is disabled **after** IP_ACCIN_DLY_3_N_32 seconds.

- 4 - **If** TCO > C_TCO_5_CFA
then LV_RLY_ACCOUT_CTRL is disabled immediately
 LV_RLY_ACCOUT is disabled **after** IP_ACCIN_DLY_3_N_32 seconds **until** TCO ≤ C_TCO_5_CFA - C_TCO_HYS_4_CFA

- 5 - **If** TPS_GRD > C_TPS_GRD_ACCIN_OFF (vehicle take-off detection)
and LV_CT = 0
and VS < C_VS_ACCIN_OFF
and N_32 < C_N_ACCIN_OFF
then LV_RLY_ACCOUT_CTRL and LV_RLY_ACCOUT are disabled immediately **during** C_ACCIN_DLY_6 seconds

Description:

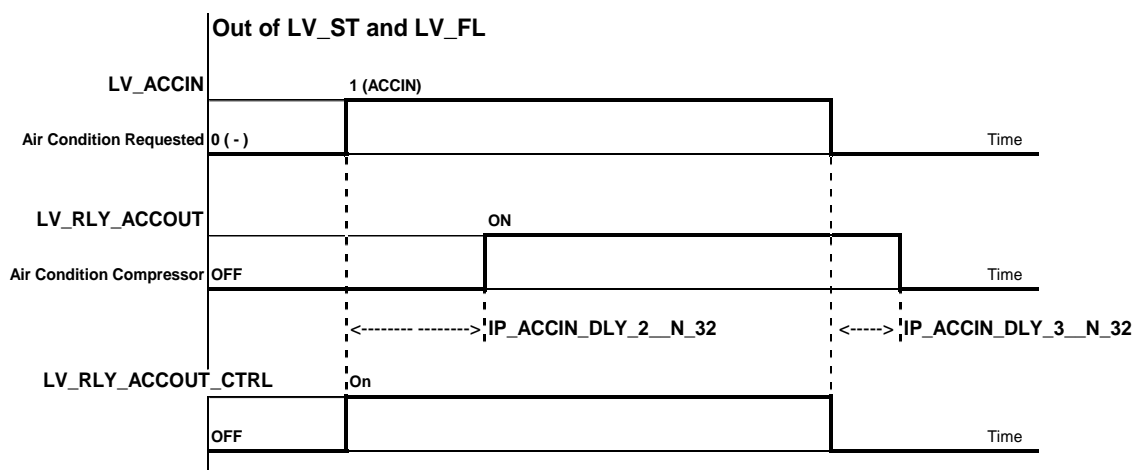

Editor: Müller O.	17-Dec-97	Auxiliary functions	HMC_V6
Version: a 153589 from 18.12.97		657765.49.08	
File: CHAP_9.DOC	650H0000	Sourcefile:07900301.00F	Page 21 / 120

Calibration data:

Name	Dim	Hex. limits	Phys. limits	Resol.	Unit
C_ACCIN_VS_MAX	1	0...FFH	0...255	1	km/h
Maximum vehicle speed to deactivate the air condition compressor in full load (LV_FL).					
C_TPS_GRD_ACCIN_OFF	1	0...FFH	0...2988	11,71	°TPS/sec
TPS_GRD threshold to detect vehicle take off					
C_VS_ACCIN_OFF	1	0...FFH	0...255	1	km/h
Vehicle speed threshold to detect vehicle take off					
C_N_ACCIN_OFF	1	0...FFH	0...8160	32	rpm
Engine speed threshold to detect vehicle take off					
C_ACCIN_DLY_1	1	01...FFH	0,1...25,5	0,1	sec
Time delay to deactivate air condition compressor in full load (LV_FL)					
IP_ACCIN_DLY_2_N_32	3	01...FFFFH	0,01...655,35	0,01	sec
Time delay to activate air condition compressor when LV_ACCIN = 1.					
IP_ACCIN_DLY_3_N_32	3	01...FFFFH	0,01...655,35	0,01	sec
Time delay to deactivate air condition compressor when LV_ACCIN = 0.					
C_ACCIN_DLY_4	1	01...FFH	0,1...25,5	0,1	sec
Time delay to deactivate air condition compressor after Start.					
C_ACCIN_DLY_5	1	01...FFH	0,1...25,5	0,1	sec
Time delay between two air condition activations.					
C_ACCIN_DLY_6	1	01...FFH	0,1...25,5	0,1	sec
Time delay between to deactivate air condition compressor in case of vehicle take off.					

Proprietary data, company confidential. All rights reserved.
 Contine a titre de secret d'entreprise. Tous droits réservés.
 Comunicado como segredo empresarial. Reservados todos os direitos.
 Confidado como secreto industrial. Nos reservamos todos los derechos.

Weitergabe sowie Vervielfältigung dieser Unterlage, Verwertung und Mitteilung ihres Inhalts nicht gestattet, soweit nicht ausdrücklich zugestanden. Zuwiderhandlungen verpflichten zu Schadensersatz. Alle Rechte vorbehalten, insbesondere für den Fall der Patenterteilung oder GM-Entragung.

Editor: Müller O.	17-Dec-97	Auxiliary functions	HMC_V6
Version: a 153589 from 18.12.97		657765.49.08	
File: CHAP_9.DOC	650H0000	Sourcefile:07900301.00F	Page 22 / 120

3 Variable intake manifold control

Output data:

Name	Mode	Hex. limits	Phys. limits	Resol.	Unit
LV_VIM	V	0...01H	0...1	1	-
Boolean for variable intake manifold control state (CLOSED / OPEN).					
LV_VIM_CTRL	V	0...01H	0...1	1	-
Boolean for variable intake manifold control target state (CLOSED / OPEN).					
T_VIM	V	0...FFH	0...25.5	0.1	s
Time counter for operation of variable intake manifold control.					
N_32_VIM	V	0...FFH	0...8160	32	rpm
Engine speed used for variable intake manifold control.					
TPS_VIM	V	0...FFH	0...119.5	0,4686	°TPS
Throttle angle used for variable intake manifold control.					

Input data:

N_32	TPS	LV_ES	LV_ST
LV_ENG_RUN_IS_PL	VB		

FUNCTION DESCRIPTION:

General information:

The variable intake system is designed to vary the inertia supercharging effect in order to improve the engine torque and the performances. At low engine speed the engine draws the intake air through long tubes to optimize the torque output, whereas at high engine speed shorter tubes are used to increase the power.

Description:

The VIM is initialized to closed position (LV_VIM=0, LV_VIM_CTRL=0) for engine stop (LV_ES =1) and start (LV_ST=1). To operate the VIM a DC-motor, whose speed depends on VB, is activated if LV_VIM_CTRL changes (0 to 1 or 1 to 0). The duration of opening/closing is determined by a counter, which makes a gradually operation possible.

At transition of LV_VIM_CTRL from 0 to 1, which indicates opening (i.e. forward motor speed) the time-counter T_VIM_(n) is increased each 100 msec until it reaches IP_T_VIM_VB, which takes into consideration the dependency on VB.

For closing (i.e. reverse motor speed) the same time-counter is increased until IP_T_VIM_VB at transition of LV_VIM_CTRL from 1 to 0. If the opening time should be different from the closing time, the difference can be calibrated by the correction factor C_T_VIM_FAC, which is applied to IP_T_VIM_VB if LV_VIM_CTRL = 0.

To avoid too many shiftings, hysteresis on N_32 and TPS are used in both directions.

The application recurrence is **100 msec**.

Editor: Müller O.	17-Dec-97	Auxiliary functions	HMC_V6
Version: a 153589 from 18.12.97		657765.49.08	
File: CHAP_9.DOC	650H0000	Sourcefile:07900601.00G	Page 23 / 120

Proprietary data, company confidential. All rights reserved. Contient des données confidentielles de l'entreprise. Tous droits réservés. Comunicado como secreto empresarial. Reservados todos os direitos. Confidado como secreto industrial. Nos reservamos todos los derechos.

Weitergabe sowie Vervielfältigung dieser Unterlage, Verbreitung und Mitteilung ihres Inhalts nicht gestattet, soweit nicht ausdrücklich zugestanden. Zuwiderhandlungen verpflichten zu Schadensersatz. Alle Rechte vorbehalten, insbesondere für den Fall der Patenterteilung oder GM-Entragung.

Application conditions:

Available for all engine operating states.

Formula section:

* *N_32_VIM-calculation:*

If LV_ES = 1
or LV_ST = 1

then N_32_VIM = N_32
else

If |N_32_VIM - N_32| > C_N_HYS_VIM
then N_32_VIM = N_32

If LV_VIM = 1 and LV_VIM_CTRL = 0 (VIM closing period)
or LV_VIM = 0 and LV_VIM_CTRL = 1 (VIM opening period)
then N_32_VIM is not updated

* *TPS_VIM-calculation:*

If LV_ES = 1
or LV_ST = 1

then TPS_VIM = TPS
else

If |TPS_VIM - TPS| > C_TPS_HYS_VIM
then TPS_VIM = TPS

If LV_VIM = 1 and LV_VIM_CTRL = 0 (VIM closing period)
or LV_VIM = 0 and LV_VIM_CTRL = 1 (VIM opening period)
then TPS_VIM is not updated

* *VIM-Activation for normal operation:*

If LV_ES = 1
or LV_ST = 1
or VS < C_VS_MIN_VIM

then LV_VIM_CTRL = 0
else LV_VIM_CTRL = ID_VIM_N_32_VIM_TPS_VIM

Remark:

If VB < C_VB_MIN_VIM then the variable intake manifold is not operated.

Editor: Müller O.	17-Dec-97	Auxiliary functions	HMC_V6
Version: a 153589 from 18.12.97		657765.49.08	
File: CHAP_9.DOC	650H0000	Sourcefile:07900601.00G	Page 24 / 120

* VIM-Activation for anti-sticking operation :

To avoid valve sticking, it is necessary to open and close the valve only one time after ignition key off is detected during power latch period.

```

if    LV_IGK=0 ( Ignition key off)
and   LV_ENG_RUN_IS_PL = 1
and   VB > C_VB_MIN_VIM

then  LV_VIM_CTRL = 1 during T_VIM period ( VIM opening) and sequentially
        LV_VIM_CTRL = 0 during T_VIM period ( VIM closing)

else  (LV_IGK = 1 detected during VIM operating)
        stop activation of VIM immediately
        close VIM after engine cranking (LV_ST = 0 and LV_ES = 0)
    
```

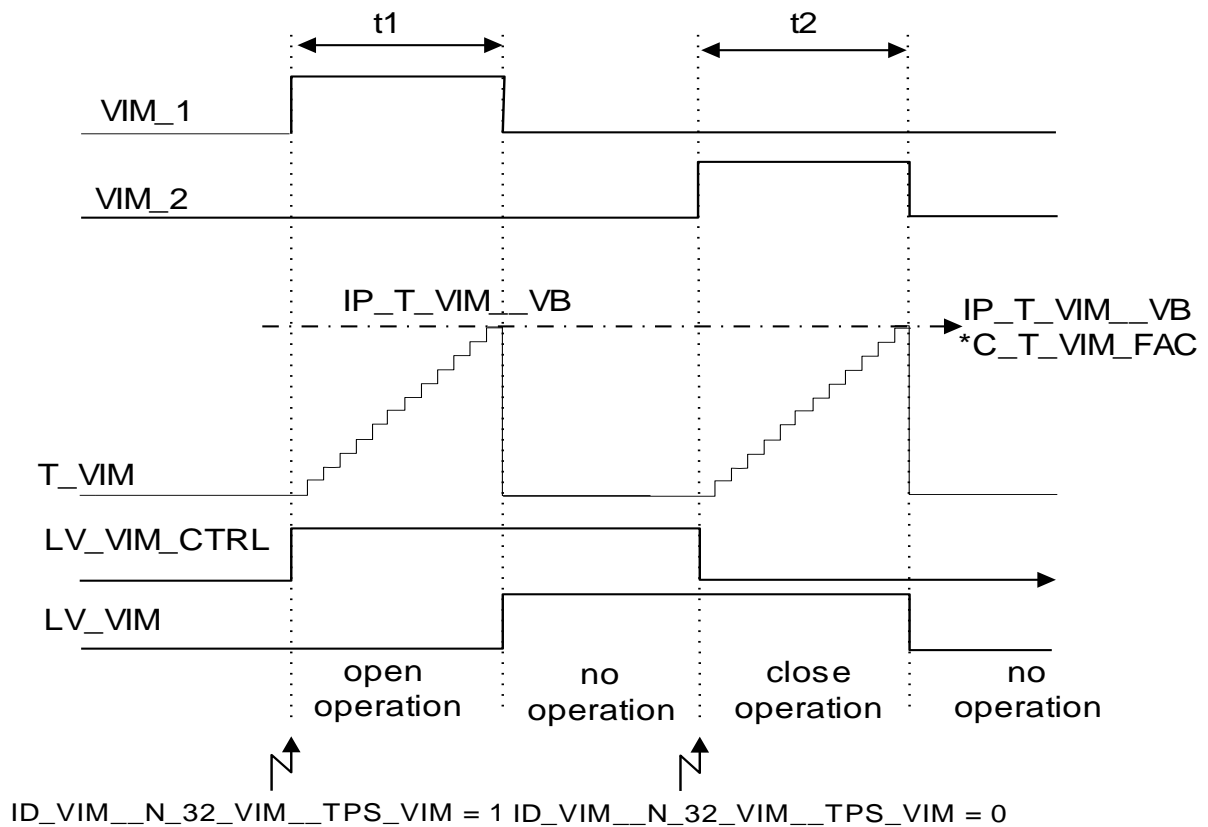

VIM_1 : opening comand from ECU
 VIM_2 : closing comand from ECU

t1 : opening time
 t2 : closing time

Editor: Müller O.	17-Dec-97	Auxiliary functions	HMC_V6
Version: a 153589 from 18.12.97		657765.49.08	
File: CHAP_9.DOC	650H0000	Sourcefile:07900601.00G	Page 25 / 120

Proprietary data, company confidential. All rights reserved. Contine a titre de secret d'entreprise. Tous droits réservés. Comunicado como segredo empresarial. Reservados todos os direitos. Confidado como secreto industrial. Nos reservamos todos los derechos.

Weitergabe sowie Vervielfältigung dieser Unterlage, Verwertung und Mitteilung ihres Inhalts nicht gestattet, soweit nicht ausdrücklich zugestanden. Zuwiderhandlungen verpflichten zu Schadensersatz. Alle Rechte vorbehalten, insbesondere für den Fall der Patenterteilung oder GM-Entragung

Calibration data:

Name	Dim	Hex. limits	Phys. limits	Resol.	Unit
ID_VIM_N_32_VIM_TPS_VIM	8 x 8	0...01H	0...1	1	-
Variable intake manifold state versus operating point (N, TPS)					
IP_T_VIM_VB	6	0...FFH	0...25,5	0,1	s
Time to operate variable intake manifold versus VB					
C_N_HYS_VIM	1	0...FFH	0...8160	32	rpm
Engine speed hysteresis to determine variable intake manifold state.					
C_TPS_HYS_VIM	1	0...FFH	0...119,5	0,47	°TPS
Throttle angle hysteresis to determine variable intake manifold state.					
C_T_VIM_FAC	1	0...FFH	0...1,992	0,0078	-
Correction factor for Variable intake manifold closing time .					
C_VB_MIN_VIM	1	0...FFH	0...25.8984	0,10116	V
Battery voltage threshold to determine variable intake manifold state.					
C_VS_MIN_VIM	1	0...FFH	0...255	1	km/h
Vehicle speed threshold to determine variable intake manifold state.					

Proprietary data, company confidential. All rights reserved.
 Contie a titre de secret d'entreprise. Tous droits réservés.
 Comunicado como segredo empresarial. Reservados todos os direitos.
 Confidado como secreto industrial. Nos reservamos todos los derechos.

Weitergabe sowie Vervielfältigung dieser Unterlage, Verwertung und Mitteilung ihres Inhalts nicht gestattet, soweit nicht ausdrücklich zugestanden. Zuwiderhandlungen verpflichten zu Schadensersatz. Alle Rechte vorbehalten, insbesondere für den Fall der Patenterteilung oder GM-Eintragung.

Editor: Müller O.	17-Dec-97	Auxiliary functions	HMC_V6
Version: a 153589 from 18.12.97		657765.49.08	
File: CHAP_9.DOC	650H0000	Sourcefile:07900601.00G	Page 26 / 120

4 Evaporative emission control

4.1 General

Input data:

LV_ES	LV_ST	LV_TI_AST	LV_IGA_AST
-------	-------	-----------	------------

The evaporative emission control is closely related to the A/F regulation loop and lambda adaptation.

In some engine operating states, these functions must be controlled in a specific manner.

In the case of A/F regulation loop for an engine with two separate exhaust - system branches, the evaporative emission control mostly interacts with only one of the two lambda controllers (i.e. determination of the charcoal canister saturation degree).

The desired cylinder group is selected using the applicative constant C_CONF_CP , please refer to chapter „General“.

Application recurrence : **100 msec.**

The application recurrence is independent to the control frequency of the CPS.

General information:

The evaporative emission control includes the following partial functions :

* *Steady operation :*

- **STB_CP operation** : no purging (evaporative emission control valve closed).
- **MIN operation** : purging with a flow rate for an unknown degree of charcoal canister saturation.
- **NORMAL operation** : purging with a flow rate adapted to the degree of charcoal canister saturation.

* *Transient operation :*

- **RAMP mode** : opening and closing the evaporative emission control valve.
- **LEARNING mode** : determination of the charcoal canister saturation degree.

The charcoal - canister purge is performed in all engine operating states except :

- engine stopped (LV_ES)
- engine operating state start (LV_ST)
- post - start function (LV_TI_AST or LV_IGA_AST) is enabled and not over.

Proprietary data, company confidential. All rights reserved.
 Contine a titre de secret d'entreprise. Tous droits réservés.
 Comunicado como segredo empresarial. Reservados todos os direitos.
 Comunicado como secreto industrial. Nos reservamos todos los derechos.

Weitergabe sowie Vervielfältigung dieser Unterlage, Verbreitung und Mitteilung ihres Inhalts nicht gestattet, soweit nicht ausdrücklich zugestanden. Zuwiderhandlungen verpflichten zu Schadensersatz. Alle Rechte vorbehalten, insbesondere für den Fall der Patenterteilung oder GM-Entragung.

Editor: Müller O.	17-Dec-97	Auxiliary functions	HMC_V6
Version: a 153589 from 18.12.97		657765.49.08	
File: CHAP_9.DOC	650H0000	Sourcefile:07900801.00L	Page 27 / 120

The duty cycle used to adjust the evaporative emission control valve (CPS) is formed of a pre-control value and a correction value during normal operation.

The degree of the charcoal-canister saturation is determined by a defined shift of this correction value by means of evaluating the A/F regulation loop signal.

The unmetered A/F mixture supplied to the engine via the evaporative emission control valve is limited to an applicable value when determining the degree of the charcoal-canister saturation. This is used to control the maximum enrichment of the mixture supplied to the engine.

Remark : If $CONF_LAM = 0$
 then charcoal-canister purge is possible only during MIN operation, due to the fact that the degree of saturation cannot be determined.

Description:

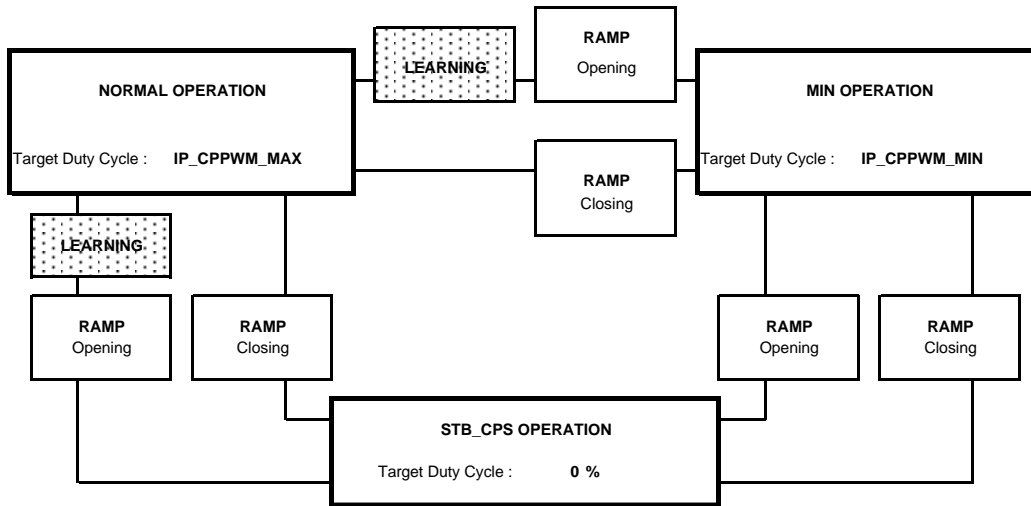

Proprietary data, company confidential. All rights reserved. Contient a titre de secret d'entreprise. Tous droits réservés. Comunicado como secreto empresarial. Reservados todos os direitos. Confidado como secreto industrial. Nos reservamos todos los derechos.

Weitergabe sowie Vervielfältigung dieser Unterlage, Verwertung und Mitteilung ihres Inhalts nicht gestattet, soweit nicht ausdrücklich zugestanden. Zuwiderhandlungen verpflichten zu Schadensersatz. Alle Rechte vorbehalten, insbesondere für den Fall der Patenterteilung oder GM-Entragung.

Editor: Müller O.	17-Dec-97	Auxiliary functions	HMC_V6
Version: a 153589 from 18.12.97		657765.49.08	
File: CHAP_9.DOC	650H0000	Sourcefile:07900801.00L	Page 28 / 120

4.2 Evaporative emission control valve duty cycle (CPPWM_CPS)

Output data:

Name	Mode	Hex. limits	Phys. limits	Resol.	Unit
CPPWM_CPS	V	00...FFH	0...99.609	0.3891	%
Evaporative emission control duty cycle corrected with the characteristic of the valve.					

Input data:

CPPWM	VB	LV_STB_PHA_CP	
-------	----	---------------	--

FUNCTION DESCRIPTION:

General information:

The control duty cycle CPPWM_CPS is formed from the opening value duty cycle calculated CPPWM (%), the valve characteristic correction IP_CPPWM_CPS__CPPWM and the battery voltage correction IP_CPPWM_CPS_VB_ADD__VB. To be sure the canister purge valve is closed in Stand-By mode, battery voltage correction is not taken in account in Stand-By mode.

Formula section:

If LV_STB_PHA_CP = 0

Then

$$CPPWM_CPS = IP_CPPWM_CPS_CPPWM + IP_CPPWM_CPS_VB_ADD_VB$$

Else

$$CPPWM_CPS = IP_CPPWM_CPS_CPPWM$$

Calibration data:

Name	Dim	Hex. limits	Phys. limits	Resol.	Unit
IP_CPPWM_CPS__CPPWM	5	00...FFH	0...99.609	0.3891	%
Evaporative emission control valve characteristic correction vs. CPPWM.					
IP_CPPWM_CPS_VB_ADD__VB	8	0...FFH	-5...4.961	10 / 256	%
Evaporative emission control valve characteristic correction vs. VB.					

Proprietary data, company confidential. All rights reserved. Contient a titre de secret d'entreprise. Tous droits réservés. Comunicado como segredo empresarial. Reservados todos os direitos. Confidado como secreto industrial. Nos reservamos todos los derechos.

Weitergabe sowie Vervielfältigung dieser Unterlage, Verwertung und Mitteilung ihres Inhalts nicht gestattet, soweit nicht ausdrücklich zugestanden. Zuwiderhandlungen verpflichten zu Schadenersatz. Alle Rechte vorbehalten, insbesondere für den Fall der Patenterteilung oder GM-Entragung.

Editor: Müller O.	17-Dec-97	Auxiliary functions	HMC_V6
Version: a 153589 from 18.12.97		657765.49.08	
File: CHAP_9.DOC	650H0000	Sourcefile:07900801.00L	Page 29 / 120

4.3 Evaporative emission control in steady operation (CPPWM)

Output data:

Name	Mode	Hex. limits	Phys. limits	Resol.	Unit
CPPWM	1	00...FFH	0...99.609	0.3891	%
Evaporative emission control duty cycle calculated.					

4.4 Evaporative emission control state STB_CP operation

Output data:

Name	Mode	Hex. limits	Phys. limits	Resol.	Unit
LV_STB_PHA_CP	V	0...01H	0...1	1	-
Evaporative emission control state : STB_CP operation.					

Input data:

TCO	LAM_TRA	FAC_CP	CPPWM
LV_AUTH_LAM_AD_CP	MAF_FAC_ALTI_MMV	PAT_INH_IV	LV_CPS_ERR
L_INH_IV_[CYL]	LV_SOV_MECHA_ERR	LV_SOV_ERR	LV_IS

FUNCTION DESCRIPTION:

General information:

The evaporative emission control valve duty cycle CPPWM and the injection time correction LAM_TRA are not computed in this evaporative emission control state.

Application conditions:

* **STB_CP** operation (LV_STB_PHA_CP) :

If TCO ≤ C_TCO_MIN_CP
 or LV_CPS_ERR = 1 (error currently present on evap. emission control valve)
 or AF regulation loop limit reached (lean or rich) for more than C_LAM_MAX_CYCNR
 or LV_SOV_ERR = 1 (error currently present on the shut-off valve)
 or LV_SOV_MECHA_ERR = 1 (mechanical problem detected on the shut-off valve)
 or L_INH_IV_[CYL] = 1 (cylinder shut - off active)
 or PAT_INH_IV ≠ 0 (fuel shut-off pattern index status)
 or (LV_IS = 1
 and MAF_FAC_ALTI_MMV < C_MAF_FAC_ALTI_IS_CP) (high altitude)

then LV_STB_PHA_CP = 1

Remark : All these conditions (except the two latest conditions) use the **RAMP** mode in the closing way to reach **STB_CP** operation state.

Editor: Müller O.	17-Dec-97	Auxiliary functions	HMC_V6
Version: a 153589 from 18.12.97		657765.49.08	
File: CHAP_9.DOC	650H0000	Sourcefile:07900801.00L	Page 30 / 120

Proprietary data, company confidential. All rights reserved. Contine a titre de secret d'entreprise. Tous droits réservés. Comunicado como segredo empresarial. Reservados todos os direitos. Confidado como secreto industrial. Nos reservamos todos los derechos.

Weitergabe sowie Vervielfältigung dieser Unterlage, Verwertung und Mitteilung ihres Inhalts nicht gestattet, soweit nicht ausdrücklich zugestanden. Zuwiderhandlungen verpflichten zu Schadensersatz. Alle Rechte vorbehalten, insbesondere für den Fall der Patenterteilung oder GM-Enttragung

Proprietary data, company confidential. All rights reserved. Contine a titre de secret d'entreprise. Tous droits réservés. Comunicado como secreto empresarial. Reservados todos os direitos. Confidado como secreto industrial. Nos reservamos todos los derechos.

Weitergabe sowie Vervielfältigung dieser Unterlage, Verwertung und Mitteilung ihres Inhalts nicht gestattet, soweit nicht ausdrücklich zugestanden. Zuwiderhandlungen verpflichten zu Schadensersatz. Alle Rechte vorbehalten, insbesondere für den Fall der Patenterteilung oder GM-Entragung.

Formula section:

```

If          LV_STB_PHA_CP = 1

then       FAC_CP = 0
and        CPPWM = 0
and        LAM_TRA = 0
and        LV_AUTH_LAM_AD_CP = 1 (Active)
    
```

4.5 Evaporative emission control state MIN operation

Output data:

Name	Mode	Hex. limits	Phys. limits	Resol.	Unit
LV_MIN_PHA_CP	V	0..01H	0..1	1	-
Evaporative emission control state : MIN operation.					

Input data:

LV_ISA_i_ERR	LV_LSH_UP_i_ERR	MAF_ALTI_COR	LV_STATE_A_MIS
LV_TPS_ERR	LV_TPS_PLAUS_ERR	LV_IV_[CYL]_ERR	CONF_CP
LV_MAF_ERR	LV_MAF_PLAUS_ERR	LV_TCO_ERR	LV_TCO_PLAUS_ERR
LV_VLS_LIM_i_ERR	LV_TIA_ERR	LV_DUR_IGC_[CYL]_ERR	LV_LSCL_i
LV_VLS_UP_i_ERR	CONF_LAM		

FUNCTION DESCRIPTION:

General information:

The evaporative emission control state **MIN** operation is used when the charcoal - canister must be purged even if the degree of saturation is unknown.

The opening of the evaporative emission control valve is designed to maintain optimal vehicle handling and emission values.

Application conditions:

* **MIN** operation (LV_MIN_PHA_CP) :

If ~~— variant with evaporative emission control, without AF regulation loop~~ (CONF_CP = 1 and CONF_LAM = 0)

- or** LV_TCO_ERR = 1 ← (error currently present on coolant temp. sensor)
- or** LV_TCO_PLAUS_ERR = 1 ← (plaus. error currently present on coolant temp. sensor)
- or** LV_TIA_ERR = 1 ← (error currently present on air temperature sensor)
- or** LV_ISA_i_ERR = 1 ← (error currently present on idle charge actuator)
- or** LV_TPS_ERR = 1 ← (error currently present on throttle position sensor)
- or** LV_TPS_PLAUS_ERR = 1 ← (error currently present on throttle position sensor)
- or** LV_MAF_ERR = 1 ← (error currently present on mass air - flow sensor)

Editor: Müller O.	17-Dec-97	Auxiliary functions	HMC_V6
Version: a 153589 from 18.12.97		657765.49.08	
File: CHAP_9.DOC	650H0000	Sourcefile:07900801.00L	Page 31 / 120

Proprietary data, company confidential. All rights reserved. Contient des informations confidentielles. Tous droits réservés. Contiene datos de la empresa. Reservados todos los derechos. Comunicado como secreto empresarial. Reservados todos os direitos. Confiado como secreto industrial. Nos reservamos todos los derechos.

```

or LV_MAF_PLAUS_ERR = 1 ← (error currently present on mass air - flow sensor)
or LV_VLS_UP_i_ERR = 1 ← (error currently present on lambda - probe voltage)
or LV_VLS_LIM_i_ERR = 1 ← (error currently present on lambda - probe voltage
excursion)
or LV_IV_[CYL]_ERR = 1 ← (error currently present on injector output)
or LV_DUR_IGC_[CYL]_ERR = 1 ← (error currently present on corresponding ignition
output)
or LV_LSH_UP_i_ERR = 1 ← (error currently present on upstream
oxygen sensor heater)
or LV_STATE_A_MIS = 1 ← (misfire status CARB A (catalyst damage))
or LV_LSCL_i = 0 ← (lambda regulation loop of the related bank open)
    
```

then LV_MIN_PHA_CP = 1

Formula section:

A canister purge solenoid CPS with non - linear characteristic needs an altitude compensation. Therefore, a load threshold can be determined to start the correction calculation for CPPWM.

If LV_MIN_PHA_CP = 1
then

If MAF_ALTI_COR > IP_MAF_ALTI_COR_MAX_CPS__N_32

then

$$CPPWM = IP_CPPWM_ALTI_COR_MIN_N_32_MAF_ALTI_COR + C_CPPWM_AS$$

(the applied duty cycle must be altitude - compensated, in order to prevent a prohibitive high lambda deviation due to evaporative emission control)

else

$$CPPWM = IP_CPPWM_MIN_N_32_MAF + C_CPPWM_AS$$

(the applied duty cycle needs no altitude compensation)

Weitergabe sowie Vervielfältigung dieser Unterlage, Verwertung und Mitteilung ihres Inhalts ist gestattet, soweit nicht ausdrücklich zugestanden. Zuwiderhandlungen verpflichten zu Schadensersatz. Alle Rechte vorbehalten, insbesondere für den Fall der Patenterteilung oder GM-Entragung.

Editor: Müller O.	17-Dec-97	Auxiliary functions	HMC_V6
Version: a 153589 from 18.12.97		657765.49.08	
File: CHAP_9.DOC	650H0000	Sourcefile:07900801.00L	Page 32 / 120

4.6 Evaporative emission control state NORMAL operation

Output data:

Name	Mode	Hex. limits	Phys. limits	Resol.	Unit
LV_NORMAL_PHA_CP	V	0...01H	0...1	1	-
Evaporative emission control state : NORMAL operation.					

Input data:

FAC_CP	MAF_ALTI_COR	
--------	--------------	--

FUNCTION DESCRIPTION:

General information:

The **NORMAL** operation is used when the determination of the degree of charcoal - canister saturation is finished and neither **MIN** operation or **STB_CP** operation are required.

For **NORMAL** operation the duty cycle CPPWM to be applied results from a pre-control map, which is altitude compensated in a defined load range.

Application conditions:

Activation:

If none of the activation conditions for **STB_CP** operation **true**
and none of the activation conditions for **MIN** operation **true**
and determination of the charcoal - canister saturation degree **not required**.

then LV_NORMAL_PHA_CP = 1

Formula section:

If LV_NORMAL_PHA_CP = 1
then

If MAF_ALTI_COR > IP_MAF_ALTI_COR_MAX_CPS__N_32

then

$CPPWM = (IP_CPPWM_ALTI_COR_MAX_N_32_MAF_ALTI_COR + C_CPPWM_AS) * FAC_CP$

(the applied duty cycle must be altitude - compensated, in order to prevent a prohibitive high lambda deviation due to evaporative emission control)

Proprietary data, company confidential. All rights reserved. Contine a titre de secret d'entreprise. Tous droits réservés. Comunicado como segredo empresarial. Reservados todos os direitos. Confidado como secreto industrial. Nos reservamos todos los derechos.

Weitergabe sowie Vervielfältigung dieser Unterlage, Verwertung und Mitteilung ihres Inhalts nicht gestattet, soweit nicht ausdrücklich zugestanden. Zuwiderhandlungen verpflichten zu Schadenersatz. Alle Rechte vorbehalten, insbesondere für den Fall der Patenterteilung oder GM-Entragung.

else

$$CPPWM = (IP_CPPWM_MAX_N_32_MAF + C_CPPWM_AS) * FAC_CP$$

(the applied duty cycle needs no altitude compensation)

Calibration data:

Name	Dim	Hex. limits	Phys. limits	Resol.	Unit
IP_CPPWM_ALTI_COR_MIN__N_32__MAF _ALTI_COR	7 x 8	0...FFH	0...99.61	0.39	%
Evaporative emission control duty cycle in MIN operation.					
IP_CPPWM_ALTI_COR_MAX__N_32__MAF _ALTI_COR	7 x 8	0...FFH	0...99.61	0.39	%
Evaporative emission control duty cycle in NORMAL operation.					
IP_MAF_ALTI_COR_MAX_CPS__N_32	3	0...FFH	0...1389	5.4471	mg/TDC
Mass air flow threshold to apply the altitude compensation on CPPWM calculation.					
C_CPPWM_AS	1	80...7FH	-50...49.609	0.3891	%
Global correction for CPS duty cycle control with Application System.					
C_MAF_FAC_ALTI_IS_CP	1	0...FFH	0...1.992	7.78 E-3	-
Mass air flow threshold of MAF_FAC_ALTI_MMV in idle for activation conditions of STB_CP operation.					
C_LAM_MAX_CYCNR	1	0...FFH	0...255	1	msec
Time delay of the A/F regulation loop on limit for activation conditions of STB_CP operation (x20 msec).					
C_TCO_MIN_CP	1	0...FEH	-48...142.5	0.75	° C
Coolant temperature threshold for activation conditions of STB_CP operation.					
IP_CPPWM_MIN__N_32__MAF	7 x 8	0...FFH	0...99.61	0.39	%
Evaporative emission control duty cycle in MIN operation.					
IP_CPPWM_MAX__N_32__MAF	7 x 8	0...FFH	0...99.61	0.39	%
Evaporative emission control duty cycle in NORMAL operation.					

Proprietary data, company confidential. All rights reserved.
 Contit a titre de secret d'entreprise. Tous droits réservés.
 Comunicado como secreto empresarial. Reservados todos os direitos.
 Confidado como secreto industrial. Nos reservamos todos los derechos.

Weitergabe sowie Vervielfältigung dieser Unterlage, Verwertung und Mitteilung ihres Inhalts nicht gestattet, soweit nicht ausdrücklich zugestanden. Zuwiderhandlungen verpflichten zu Schadenersatz. Alle Rechte vorbehalten, insbesondere für den Fall der Patenterteilung oder GM-Entragung.

Editor: Müller O.	17-Dec-97	Auxiliary functions	HMC_V6
Version: a 153589 from 18.12.97		657765.49.08	
File: CHAP_9.DOC	650H0000	Sourcefile:07900801.00L	Page 34 / 120

4.7 Evaporative emission control duration (T_CP)

Output data:

Name	Mode	Hex. limits	Phys. limits	Resol.	Unit
T_CP	V	01...FFFFH	0.1...6553.5	0.1	sec
Evaporative emission control duration.					

Input data:

LV_ST	LV_PL	LV_IS	LV_AUTH_LAM_AD_CP
LAM_MV_BEG			

FUNCTION DESCRIPTION:

General information:

The evaporative emission control process is divided into time ranges : Injection time adaptation and canister purge are active alternatively.

Time range T_CP starts following the transition from the engine operating state Start (LV_ST) to Idle (LV_IS) or Part Load (LV_PL) with C_T_1_CP (Canister purge active). This time range is followed by the alternating time ranges C_TI_T_AD_1 (Injection time adaptation active) and C_T_2_CP (Canister purge active).

At the beginning of the C_TI_T_AD_1 time ranges, the evaporative emission control valve is closed via the **RAMP** mode and the lambda adaptation can be performed (LV_AUTH_LAM_AD_CP = 1 (Active)).

The maximum duration of **NORMAL** operation is therefore time T_CP minus the time required to determine the charcoal - canister saturation degree (**LEARNING** mode).

Under certain conditions, **NORMAL** operation is intercepted when **STB_CP** operation or **MIN** operation is required or for instance, when a determination of the charcoal - canister saturation degree is required.

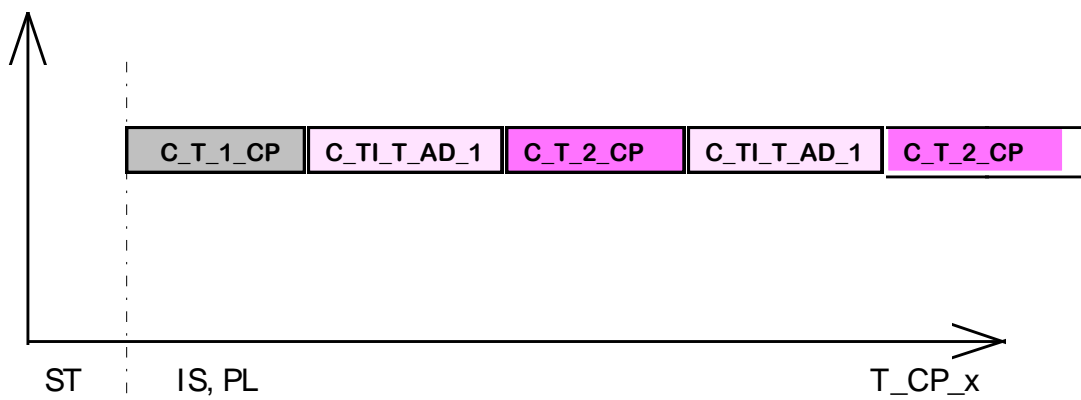

This pre-defined time sequence for injection time adaptation and canister purge can be modified in case of big TI_LAM deviation. If LAM_MV_BEG is out of pre-defined limits, injection time adaptation is immediately activated.

If | LAM_MV_BEG | > C_LAM_MV_BEG_MAX

Then

T_CP is reseted and swiches to the next sequence (injection time adaptation C_TLT_AD_1)

Calibration data:

Name	Dim	Hex. limits	Phys. limits	Resol.	Unit
C_T_1_CP	1	01...FFFFH	0.1...6553.5	0.1	sec
Duration after start to perform the evaporative emission control process.					
C_T_2_CP	1	01...FFFFH	0.1...6553.5	0.1	sec
Duration to perform a purging phase on NORMAL or MIN operation.					
C_TI_T_AD_1	1	01...FFFFH	0.1...6553.5	0.1	sec
Duration to perform the lambda adaptation without purging evaporative emission.					
C_LAM_MV_BEG_MAX	1	8000...FFFFH	0...49.998	1.526E-3	%
Maximum LAM_MV_BEG absolute value to perform canister saturation degree determination					

Proprietary data, company confidential. All rights reserved.
 Contine a titre de secret d'entreprise. Tous droits réservés.
 Comunicado como secreto empresarial. Reservados todos os direitos.
 Confidado como secreto industrial. Nos reservamos todos los derechos.

Weitergabe sowie Vervielfältigung dieser Unterlage, Verwertung und Mitteilung ihres Inhalts nicht gestattet, soweit nicht ausdrücklich zugestanden. Zuwiderhandlungen verpflichten zu Schadensersatz. Alle Rechte vorbehalten, insbesondere für den Fall der Patenterteilung oder GM-Entragung.

Editor: Müller O.	17-Dec-97	Auxiliary functions	HMC_V6
Version: a 153589 from 18.12.97		657765.49.08	
File: CHAP_9.DOC	650H0000	Sourcefile:07900801.00L	Page 36 / 120

4.8 Evaporative emission control in transient operation (FAC_CP)

4.8.1 Evaporative emission control mode : RAMP mode

Output data:

Name	Mode	Hex. limits	Phys. limits	Resol.	Unit
FAC_CP	V	00...FFH	0...1.000	3.906E-3	-
Opening or closing ramp slope of the evaporative emission control valve.					
FAC_BEG_CP	V	00...FFH	0...1.000	3.906E-3	-
Ramp slope initialisation of the evaporative emission control valve.					
LV_SLOP_CP	V	0...01H	0...1	1	-
Evaporative emission control state : RAMP mode.					

Input data:

IP_CPPWM_MAX__N__MAF	IP_CPPWM_MIN__N__MAF	CPPWM	LV_LAM_LIM_CDN
----------------------	----------------------	-------	----------------

FUNCTION DESCRIPTION:

General information:

The **RAMP** mode serves as a transition function between the three different steady states of the evaporative emission control process (**STB_CP** operation, **NORMAL** operation, **MIN** operation) in the opening or closing way.

The duty cycle CPPWM during **RAMP** mode is calculated like in **NORMAL** operation with the difference that FAC_CP is variable by decrement or increment.

During **RAMP** mode LV_SLOP_CP = 1.

Proprietary data, company confidential. All rights reserved. Contient a titre de secret d'entreprise. Tous droits réservés. Comunicado como segredo empresarial. Reservados todos os direitos. Confidado como secreto industrial. Nos reservamos todos los derechos.

Weitergabe sowie Vervielfältigung dieser Unterlage, Wertung und Mitteilung ihres Inhalts nicht gestattet, soweit nicht ausdrücklich zugestanden. Zuwiderhandlungen verpflichten zu Schadenersatz. Alle Rechte vorbehalten, insbesondere für den Fall der Patenterteilung oder GM-Entragung.

Editor: Müller O.	17-Dec-97	Auxiliary functions	HMC_V6
Version: a 153589 from 18.12.97		657765.49.08	
File: CHAP_9.DOC	650H0000	Sourcefile:07900801.00L	Page 37 / 120

Proprietary data, company confidential. All rights reserved. Contine a titre de secret d'entreprise. Tous droits réservés. Comunicado como segredo empresarial. Reservados todos os direitos. Confidado como secreto industrial. Nos reservamos todos los derechos.

Weitergabe sowie Vervielfältigung dieser Unterlage, Wertung und Mitteilung ihres Inhalts nicht gestattet, soweit nicht ausdrücklich zugestanden. Zuwiderhandlungen verpflichten zu Schadensersatz. Alle Rechte vorbehalten, insbesondere für den Fall der Patenterteilung oder GM-Entragung.

Application conditions:

- Exit to : **STB_CP** operation

Closing ramp :

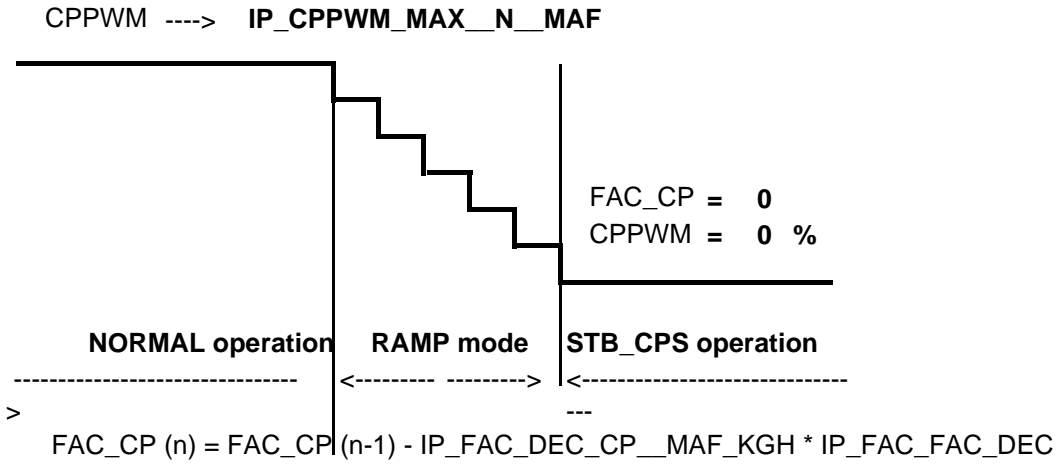

Closing ramp :

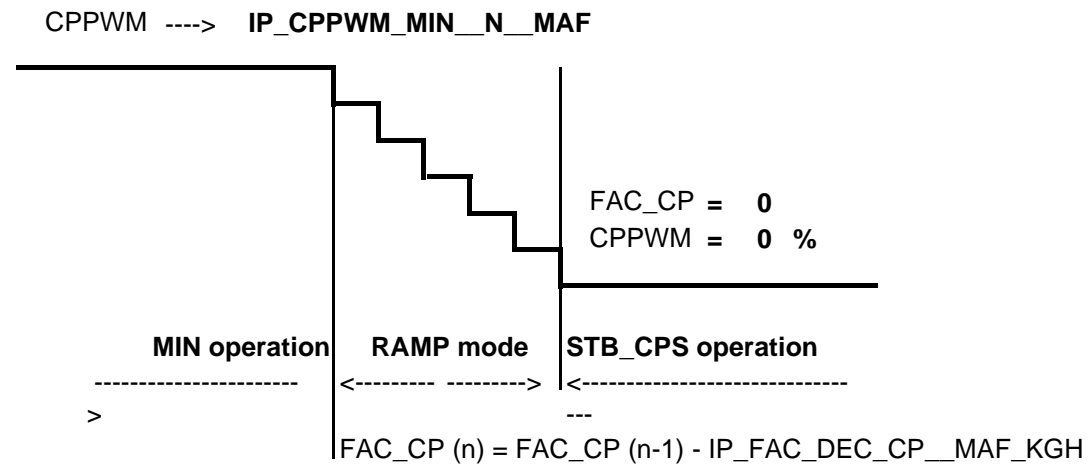

$$CPPWM_{(n)} = CPPWM_{(n-1)} * FAC_CP$$

If no value FAC_CP is available upon entry in **RAMP** mode (i.e. previous operation state was **MIN** operation), FAC_CP is computed with FAC_BEG_CP as follows :

$$FAC_BEG_CP = CPPWM_{(n-1)} / IP_CPPWM_MAX_N_MAF$$

Editor: Müller O.	17-Dec-97	Auxiliary functions	HMC_V6
Version: a 153589 from 18.12.97		657765.49.08	
File: CHAP_9.DOC	650H0000	Sourcefile:07900801.00L	Page 38 / 120

- Exit to : **MIN** operation

Opening ramp :

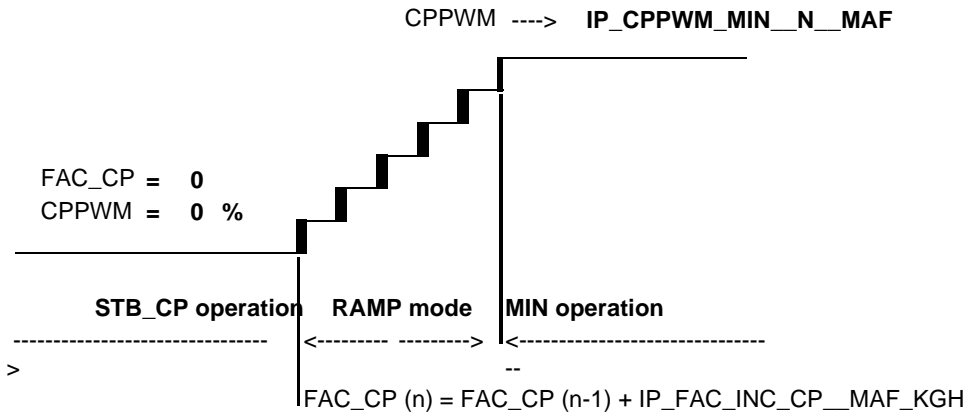

Closing ramp :

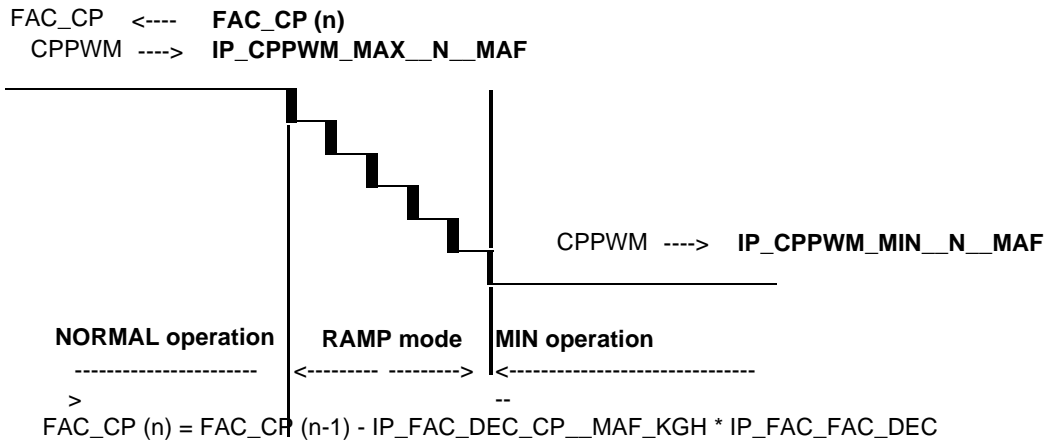

$$CPPWM_{(n)} = CPPWM_{(n-1)} * FAC_CP$$

Formula section:

* *Opening ramp :*

$$FAC_CP_{(n)} = FAC_CP_{(n-1)} + IP_FAC_INC_CP_MAF_KGH$$

* *Closing ramp :*

$$FAC_CP_{(n)} = FAC_CP_{(n-1)} - IP_FAC_DEC_CP_MAF_KGH$$

Remark: the closing ramp decrement is multiplied with a factor, if a saturation degree is available, that means Normal-mode was active before closing ramp.

Proprietary data, company confidential. All rights reserved. Contine a titre de secret d'entreprise. Tous droits réservés. Comunicado como secreto empresarial. Reservados todos os direitos. Confidado como secreto industrial. Nos reservamos todos los derechos.

Weitergabe sowie Vervielfältigung dieser Unterlage, Verbreitung und Mitteilung ihres Inhalts nicht gestattet, soweit nicht ausdrücklich zugestanden. Zuwiderhandlungen verpflichten zu Schadensersatz. Alle Rechte vorbehalten, insbesondere für den Fall der Patenterteilung oder GM-Enttragung.

Editor: Müller O.	17-Dec-97	Auxiliary functions	HMC_V6
Version: a 153589 from 18.12.97		657765.49.08	
File: CHAP_9.DOC	650H0000	Sourcefile:07900801.00L	Page 39 / 120

Remark :

- The decrement and increment are applied as a function of mass air flow and are mutually independent.
- If the lambda controller reaches its own limits (LV_LAM_LIM_CDN = 1), then FAC_CP is weighted with C_COR_FAC_INC_CP only during **LEARNING** mode with **RAMP** opening.
- The decrement of the closing ramp is multiplied with a saturation-degree-depending factor to make the closing time shorter with lower saturation degrees.
- If the CPPWM reaches during closing ramp C_CPPWM_CLOSE then CPPWM is closed immediately and FAC_CP and LAM_TRA are set to 0.

Calibration data:

Name	Dim	Hex. limits	Phys. limits	Resol.	Unit
IP_FAC_INC_CP_MAF_KGH	8	00...FFH	0...1.000	3.906E-3	-
Incrementation of the ramp slope for opening the evaporative emission control valve CPS.					
IP_FAC_DEC_CP_MAF_KGH	8	00...FFH	0...1.000	3.906E-3	-
Decrementation of the ramp slope for closing the evaporative emission control valve CPS.					
C_COR_FAC_INC_CP	1	00...FFH	0...0.996	3.891E-3	-
Weighting factor for FAC_CP when the lambda controller reaches its limits.					
IP_FAC_FAC_DEC	6	0...FFH	0...31,875	0,125	-
LAM_MV_DIF_CP					
Factor for closing ramp decrement, depending on saturation degree.					
C_CPPWM_CLOSE	1	0...FFH	0...99,6	0,3891	%
Threshold for immediately closing CPS					

Proprietary data, company confidential. All rights reserved.
 Contine a titre de secret d'entreprise. Tous droits réservés.
 Comunicado como secreto empresarial. Reservados todos os direitos.
 Confidado como secreto industrial. Nos reservamos todos los derechos.

Weitergabe sowie Vervielfältigung dieser Unterlage, Verwertung und Mitteilung ihres Inhalts nicht gestattet, soweit nicht ausdrücklich zugestanden. Zuwiderhandlungen verpflichten zu Schadensersatz. Alle Rechte vorbehalten, insbesondere für den Fall der Patenterteilung oder GM-Entragung.

Editor: Müller O.	17-Dec-97	Auxiliary functions	HMC_V6
Version: a 153589 from 18.12.97		657765.49.08	
File: CHAP_9.DOC	650H0000	Sourcefile:07900801.00L	Page 40 / 120

4.9 Evaporative emission control mode : LEARNING mode

Output data:

Name	Mode	Hex. limits	Phys. limits	Resol.	Unit
LAM_MV_DIF_CP	V	00...FFFFH	-50...49.998	1.526E-3	%
Degree of the charcoal - canister saturation.					
LAM_MV_DIF_CP_LD	V	00...FFFFH	-50...49.998	1.526E-3	%
Degree of the charcoal - canister saturation for fuel system diagnosis inhibition.					
LV_LEARN_CP	V	0...01H	0...1	1	-
Evaporative emission control state : LEARNING mode.					
LAM_MV_BEG	V	0...FFFFH	-50...49.998	1.526E-3	%
Value of LAM_MV at the beginning of RAMP mode					

Input data:

TI_LAM_i	LAM_MV_i	LAM_MV_DIF_COR_CP	CPPWM
FAC_BEG_CP	IP_CPPWM_MIN__N__MAF	LAM_TRA	LV_PUC
LV_FL	IP_CPPWM_MAX__N__MAF	T_CP	FAC_CP
IP_LAM_CP__N__32__MAF _ALTI_COR	LV_AUTH_LAM_i_AD_LEARN _CP	N_32	MAF_ALTI_COR

FUNCTION DESCRIPTION:

Application conditions:

Target duty cycle : **NORMAL** operation (IP_CPPWM_MAX__N__MAF)

The determination of the charcoal-canister saturation degree is **required** and **possible** in **STB_CP** operation and **MIN** operation.

If

*The determination of the charcoal - canister saturation degree is **required** :*

If (time range T_CP starts (T_CP = C_T_2_CP) and **STB_CP** operation or **MIN** operation has been triggered before)

or $TI_LAM_i_{(n)} < C_LAM_MIN_CP$ is detected in **NORMAL** operation

or $|LAM_MV_DIF_COR_CP_{(n)}| > C_LAM_MV_DIF_COR_MAX_CP$ is detected in **NORMAL** operation.

Editor: Müller O.	17-Dec-97	Auxiliary functions	HMC_V6
Version: a 153589 from 18.12.97		657765.49.08	
File: CHAP_9.DOC	650H0000	Sourcefile:07900801.00L	Page 41 / 120

Proprietary data, company confidential. All rights reserved.
 Contient des données confidentielles. Tous droits réservés.
 Comunicado como secreto empresarial. Reservados todos los derechos.
 Confidado como secreto industrial. Nos reservamos todos los derechos.

Weitergabe sowie Vervielfältigung dieser Unterlage, Verwertung und Mitteilung ihres Inhalts nicht gestattet, soweit nicht ausdrücklich zugestanden. Zuwiderhandlungen verpflichten zu Schadensersatz. Alle Rechte vorbehalten, insbesondere für den Fall der Patenterteilung oder GM-Entragung.

Proprietary data, company confidential. All rights reserved. Contine a titre de secret d'entreprise. Tous droits réservés. Comunicado como secreto empresarial. Reservados todos os direitos. Confidado como secreto industrial. Nos reservamos todos los derechos.

Weitergabe sowie Vervielfältigung dieser Unterlage, Verwertung und Mitteilung ihres Inhalts nicht gestattet, soweit nicht ausdrücklich zugestanden. Zuwiderhandlungen verpflichten zu Schadensersatz. Alle Rechte vorbehalten, insbesondere für den Fall der Patenterteilung oder GM-Enttragung

The determination of the charcoal - canister saturation degree is **possible** if :

- if** LV_LAM_ACT_i = 1 (Active)
(lambda controller operability in its own limits)
- and** LV_LS_i = 1 (Active)
(A/F regulation oxygen sensor operability effective)
- and** LV_N_MAF_DYW_i = 1 (Active)
(engine speed and load dynamics condition status)
- and** C_CPPWM_AD_MIN < IP_CPPWM_MAX_N_MAF < C_CPPWM_AD_MAX
(determination of the charcoal - canister saturation degree only in useful load range)
- and** IP_LAM_CP_N_32_MAF_ALTI_COR ≥ C_LAM_TRA_STATE_MIN
(consideration of altitude influence for purging capability)

then LV_LEARN_CP = 1

General information:

The determination of the charcoal - canister saturation degree is performed according to the following actions :

- 1 - determination of the A/F regulation loop value LAM_MV_BEG = LAM_MV_(n) with the evaporative emission control valve completely or partially closed.
(stabilisation for LAM_MV_BEG determination with waiting for C_FAC_MIN_P_CP - p-jumps
and
injection time adaptation LV_AUTH_LAM_i_AD_LEARN_CP = 1 (Active))
- 2 - defined opening of the evaporative emission control valve (**RAMP** mode).
- 3 - determination of the A/F regulation loop value LAM_MV_(n) with the evaporative emission control valve open.

(LAM_MV_(n) - LAM_MV_BEG) is representative of the charcoal-canister saturation degree

This determination operates only in a quasi - stationary suitable operating point for the engine. (refer to the section " *Activation of the learning mode* ")

The tuning of the ramp slope must assume that the A/F ratio controller can compensate the deviation of the lambda, which results from the purge flow rate through the evaporative emission control valve.

The determination of the charcoal - canister saturation degree is most accurate when the evaporative emission control valve is completely closed at the beginning.

However, in some cases, it makes sense to only close the evaporative emission control valve to duty cycle in **MIN** operation, in order to obtain the necessary charcoal - canister purge rate.

Application conditions:

- First determination of the charcoal - canister saturation degree :

Editor: Müller O.	17-Dec-97	Auxiliary functions	HMC_V6
Version: a 153589 from 18.12.97		657765.49.08	
File: CHAP_9.DOC	650H0000	Sourcefile:07900801.00L	Page 42 / 120

Proprietary data, company confidential. All rights reserved.
 Contient des informations confidentielles. Tous droits réservés.
 Comunicado como segredo empresarial. Reservados todos os direitos.
 Confidado como secreto industrial. Nos reservamos todos los derechos.

Weitergabe sowie Vervielfältigung dieser Unterlage, Verwertung und Mitteilung ihres Inhalts ist gestattet, soweit nicht ausdrücklich zugestanden. Zuwiderhandlungen verpflichten zu Schadensersatz. Alle Rechte vorbehalten, insbesondere für den Fall der Patenterteilung oder GM-Entragung.

The first determination of the charcoal - canister saturation degree begin only from **STB_CP** operation (CPPWM = 0 %) and within T_CP, as long as C_SUM_STATE_MAX has been reached (maximum number of attempts to determine the charcoal - canister saturation degree).

The corresponding counter is incremented when a determination of the charcoal - canister saturation degree has been aborted after computation of LAM_MV_BEG.

- Initialisation value FAC_BEG_CP of FAC_CP for each determination of the charcoal - canister saturation degree :

. From **STB_CP** operation :

$$FAC_BEG_CP = 0$$

. From **MIN** operation (only when C_SUM_STATE_MAX has been reached)

$$FAC_BEG_CP = CPPWM_{(n-1)} / IP_CPPWM_MAX_N_MAF$$

Formula section:

- Sequence for determination of charcoal - canister saturation degree :

- 1 - Activation conditions for **LEARNING** mode enabled
- 2 - Determine LAM_MV_BEG
- 3 - Opening evaporative emission control valve using **RAMP** mode.
The opening **RAMP** cannot be stopped until there is a minimum opening of the evaporative emission control valve in order to get a reliable result :

$$FAC_CP_{(n)} / (FAC_CP_{(n)} - FAC_BEG_CP) \leq C_FAC_CP_LD_MAX$$

If during **LEARNING** mode this condition is fulfilled, there are several possibilities to stop the **RAMP** mode :

If FAC_CP = 1
or [FAC_CP_(n) / (FAC_CP_(n) - FAC_BEG_CP)] <= C_FAC_CP_LD_MAX
and A/F regulation loop limit is reached

or | TI_LAM_(n)+LAM_TRA - LAM_MV_BEG |
 ≥ IP_LAM_DIF_MAX_CP__N_32__MAF_ALTI_COR

Editor: Müller O.	17-Dec-97	Auxiliary functions	HMC_V6
Version: a 153589 from 18.12.97		657765.49.08	
File: CHAP_9.DOC	650H0000	Sourcefile:07900801.00L	Page 43 / 120

Proprietary data, company confidential. All rights reserved. Contine a titre de secret d'entreprise. Tous droits réservés. Comunicado como segredo empresarial. Reservados todos os direitos. Confidado como secreto industrial. Nos reservamos todos los derechos.

Weitergabe sowie Vervielfältigung dieser Unterlage, Verwertung und Mitteilung ihres Inhalts nicht gestattet, soweit nicht ausdrücklich zugestanden. Zuwiderhandlungen verpflichten zu Schadensersatz. Alle Rechte vorbehalten, insbesondere für den Fall der Patenterteilung oder GM-Enttragung

- 4 - The lambda deviation is shifted to LAM_TRA for the first time if : $(LAM_MV_BEG - TI_LAM_{(n)}) > C_LAM_DIF_MAX_TRA$

The lambda controller is shifted of the equivalent LAM_TRA.

This process is activated every time the lambda deviation is more than C_LAM_DIF_MAX_TRA.

There will be a deviation of the lambda controller if the charcoal - canister is not totally empty.

Thus, it is possible to minimize the lambda deviation if there is any load condition changing during the **RAMP** opening.

- 5 - At the end of **RAMP** operation, stabilisation (limited LAM (n) dynamics condition) for $C_FAC_MIN_P_CP * P$ -jumps of the A/F regulation loop.

$$LAM_MV_DIF_CP_{(n)} = (LAM_MV_{(n)} + LAM_TRA - LAM_MV_BEG) \times [FAC_CP_{(n)} / (FAC_CP_{(n)} - FAC_BEG_CP)]$$

- 6 - Limitation of positive lambda deviation : $LAM_MV_DIF_CP_{(n)} \leq C_LAM_MV_DIF_MAX_1_CP$
- 7 - Fuel system diagnosis interface : $LAM_MV_DIF_CP_LD = LAM_MV_DIF_CP_{(n)}$
- 8 - LAM_MV_DIF_COR_CP is initialized with 0 at the end of the ramp.

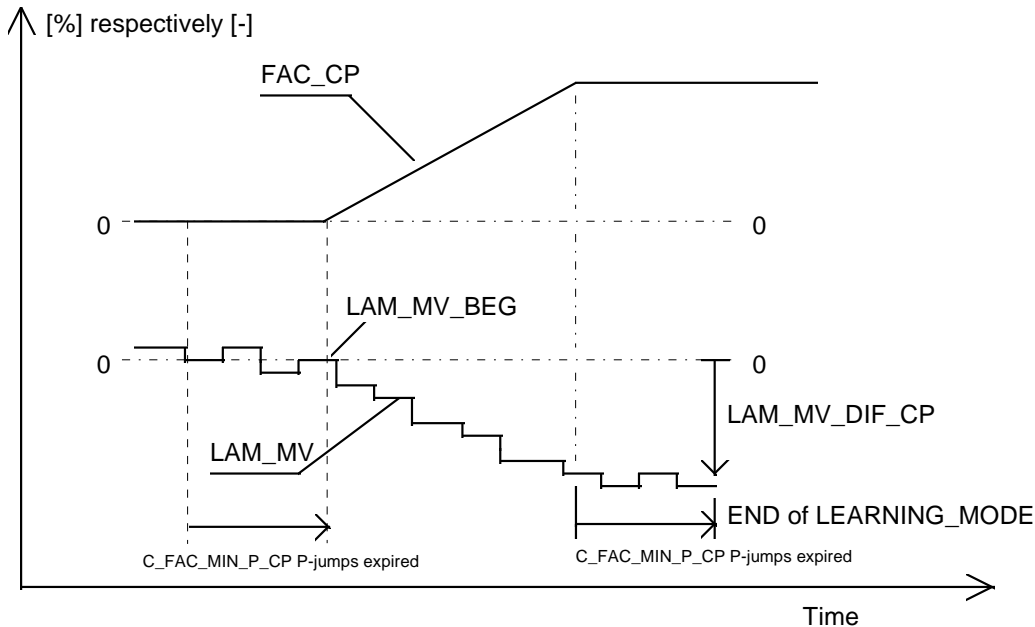

Editor: Müller O.	17-Dec-97	Auxiliary functions	HMC_V6
Version: a 153589 from 18.12.97		657765.49.08	
File: CHAP_9.DOC	650H0000	Sourcefile:07900801.00L	Page 44 / 120

Remark :

- The opening ramp is complete at the latest when FAC_CP = 1.
- If the A/F regulation loop is open during the **RAMP** mode (trailing throttle fuel cut off (LV_PUC full load (LV_FL) ...), the **RAMP** mode is aborted, FAC_CP and TI_LAM are retained and a timer C_T_LAM_MAX_STATE is started. If the A/F regulation loop is closed again before expiration of this timer, the **RAMP** is continued.

Otherwise, depending of the activation conditions, the evaporative emission control valve is totally closed to **STB_CP** operation (CPPWM = 0 %) without **RAMP** mode or partially to **MIN** operation (IP_CPPWM_MIN_N_MAF) with **RAMP** mode.

- If a new determination of the charcoal - canister saturation degree is requested then LAM_MV_MMV = LAM_MV_BEG = LAM_MV and LAM_MV_DIF_COR_CP = 0.

Calibration data:

Name	Dim	Hex. limits	Phys. limits	Resol.	Unit
C_SUM_STATE_MAX	1	0...FFH	0...255	1	-
Maximum number of attempts to determine the charcoal - canister saturation degree.					
C_FAC_MIN_P_CP	1	0...FFH	0...255	1	-
Counter to validate the limited N / MAF dynamics condition.					
C_T_LAM_MAX_STATE	1	01...FFH	0.1...25.5	0.1	sec.
Maximum value of the timer to enable again the ramp when A/F regulation loop has been opened.					
C_LAM_MV_DIF_MAX_1_CP	1	B000...5000H	-31.25...31.25	0.0015	%
LAM_MV_DIF_CP high threshold in RAMP mode for LEARNING mode					
IP_LAM_DIF_MAX_CP	7*8	1...FFFFH	0...99,6	0.0015	%
LAM_DIF_CP high threshold in RAMP mode for LEARNING mode.					
C_LAM_DIF_MAX_TRA	1	8000...D000H	0...31.25	0.0015	%
LAM_DIF condition to shift LAM_TRA during LEARNING mode.					
C_FAC_CP_LD_MAX	1	0100...0500H	1...5	1 / 256	-
Minimum factor for reliable opening of the evaporative emission control valve.					
C_LAM_TRA_STATE_MIN	1	01...4000H	0.00...0.25	0.000015 3	-
Weighting factor threshold for the injection time correction LAM_TRA.					
C_CPPWM_AD_MAX	1	00...FFH	0...99.609	0.3891	%
High threshold of the purging duty cycle for activation conditions of LEARNING mode.					
C_CPPWM_AD_MIN	1	00...FFH	0...99.609	0.3891	%
Low threshold of the purging duty cycle for activation conditions of LEARNING mode.					
C_LAM_MIN_CP	1	3000...8000H	-31.25...0	-0.00153	%
LAM threshold for activation conditions of LEARNING mode.					
C_LAM_MV_DIF_COR_MAX_CP	1	8000...D000H	0...31.25	0.00153	%
LAM_MV_DIF_COR_CP threshold for activation conditions of LEARNING mode.					

Proprietary data, company confidential. All rights reserved. Contine a titre de secret d'entreprise. Tous droits réservés. Comunicado como segredo empresarial. Reservados todos os direitos. Confidado como secreto industrial. Nos reservamos todos los derechos.

Weitergabe sowie Vervielfältigung dieser Unterlage, Verwertung und Mitteilung ihres Inhalts ist nicht gestattet, soweit nicht ausdrücklich zugestanden. Zuwiderhandlungen verpflichten zu Schadenersatz. Alle Rechte vorbehalten, insbesondere für den Fall der Patenterteilung oder GM-Entragung.

Editor: Müller O.	17-Dec-97	Auxiliary functions	HMC_V6
Version: a 153589 from 18.12.97		657765.49.08	
File: CHAP_9.DOC	650H0000	Sourcefile:07900801.00L	Page 45 / 120

4.10 Injection time correction with evaporative emission control (LAM_TRA)

Output data:

Name	Mode	Hex. limits	Phys. limits	Resol.	Unit
LAM_TRA	V	0...FFH	-50...49.609	0.39	%
Injection time correction.					
LAM_MV_i	V	0...FFH	-50...49.609	0.39	%
Moving average value of LAM.					
LAM_MV_MMV	V	4000...C000H	-25...24.9985	0.0015	%
Moving average value of LAM_MV.					
LAM_MV_MMV_DIF	V	00...FFFFH	-50...49.998	1.526E-3	%
LAM_MV_MMV deviation in NORMAL operation used for updating injection time correction LAM_TRA.					
LAM_MV_DIF_COR_CP	V	3000...D000H	-31.25...31.25	0.00153	%
LAM_MV_MMV-deviation during Normal-operation for request of a new learning					

Input data:

LAM_MV_DIF_CP	IP_CPPWM_MAX_N_MAF	CPPWM	C_LAM_TRA_STATE_MIN
MAF	C_LAM_MV_DIF_COR_MAX_CP	TI_LAM	C_LAM_DIF_MAX_TRA
MAF_KGH	IP_CPPWM_MIN_N_MAF	MAF_ALTI_COR	IP_CPPWM_ALTI_COR_MAX_N_32_MAF_ALTI_COR
LAM_MV_BEG	LV_LS_i	LV_N_MAF_DYW_i	LV_LAM_ACT_i
N_32			

FUNCTION DESCRIPTION:

General information:

The injection time correction due to the mixture influence from the evaporative emission control is performed only in the **NORMAL** operation state, following the **LEARNING** mode.

During tuning activity in **NORMAL** operation, a variable set value is determined for the A/F regulation loop controller.

This set value is stored in a table IP_LAM_CP_N_32_MAF_ALTI_COR depending on engine operating point.

It corresponds to the real lambda deviation if the evaporative emission control valve is controlled with IP_CPPWM_ALTI_COR_MAX_N_32_MAF_ALTI_COR or IP_CPPWM_MAX_N_32_MAF and the charcoal - canister totally saturated.

For the calculation of LAM_TRA the result of the **LEARNING** mode LAM_MV_DIF_CP is weighted for different load condition.

Editor: Müller O.	17-Dec-97	Auxiliary functions	HMC_V6
Version: a 153589 from 18.12.97		657765.49.08	
File: CHAP_9.DOC	650H0000	Sourcefile:07900801.00L	Page 46 / 120

Proprietary data, company confidential. All rights reserved. Contine a titre de secret d'entreprise. Tous droits réservés. Comunicado como segredo empresarial. Reservados todos os direitos. Confidado como secreto industrial. Nos reservamos todos los derechos.

Weitergabe sowie Vervielfältigung dieser Unterlage, Verwertung und Mitteilung ihres Inhalts nicht gestattet, soweit nicht ausdrücklich zugestanden. Zuwiderhandlungen verpflichten zu Schadensersatz. Alle Rechte vorbehalten, insbesondere für den Fall der Patenterteilung oder GM-Entragung.

Proprietary data, company confidential. All rights reserved. Contine a titre de secret d'entreprise. Tous droits réservés. Comunicado como segredo empresarial. Reservados todos os direitos. Confidado como secreto industrial. Nos reservamos todos los derechos.

Weitergabe sowie Vervielfältigung dieser Unterlage, Verbreitung und Mitteilung ihres Inhalts nicht gestattet, soweit nicht ausdrücklich zugestanden. Zuwiderhandlungen verpflichten zu Schadenersatz. Alle Rechte vorbehalten, insbesondere für den Fall der Patenterteilung oder GM-Entragung.

Formula section:

1 - Injection time correction :

$$LAM_TRA = LAM_MV_DIF_CP_{(n)} * IP_LAM_CP_{(0)} / IP_LAM_CP_{(n)}$$

(0) : current value
(n) : last determination of LAM_MV_DIF_CP

```

if      MAF_ALTI_COR > IP_MAF_ALTI_COR_MAX_CPS__N_32
then    IP_LAM_CP = IP_LAM_CP__N_32_MAF_ALTI_COR
else    IP_LAM_CP = IP_LAM_CP__N_32_MAF
    
```

The calculation of LAM_TRA is activated the first time during **LEARNING** mode and is continued until the end of **NORMAL** operation.

At the end of **NORMAL** operation, LAM_TRA is decremented step by step. (refer to "Injection time correction LAM_TRA during RAMP operation")

All changes of LAM_TRA which are not compensated by shift of the lambda controller in the opposite direction are limited in speed by the gradient limitation IP_LAM_TRA_LGRD__MAF_KGH.

2 - Weighting of the injection time correction :

2.1 - Injection time correction LAM_TRA during RAMP operation :

a - During opening **RAMP** and the first **LEARNING** mode, the following calculations are performed if (LAM_MV_BEG - LAM_(n)) > C_LAM_DIF_MAX_TRA :

$$LAM_MV_DIF_CP = C_LAM_DIF_MAX_TRA$$

and $LAM_TRA = LAM_MV_DIF_CP_{(n)} * IP_LAM_CP_{(0)} / IP_LAM_CP_{(n)}$

TI_LAM_(n) , LAM_MV_(n) and LAM_MV_MMV_(n) are shifted in the opposite direction.

b - The next time where (LAM_MV_BEG - TI_LAM_(n)) > C_LAM_DIF_MAX_TRA the following calculation is activated :

1 - $LAM_TRA = (LAM_MV_DIF_CP_{(n)} * IP_LAM_CP_{(0)} / IP_LAM_CP_{(n)}) - C_LAM_DIF_MAX_TRA$

2 - IP_LAM_CP_(n) is updated and LAM_MV_DIF_CP = LAM_TRA.

The same algorithm is performed as long as the lambda deviation is higher than C_LAM_DIF_MAX_TRA.

Editor: Müller O.	17-Dec-97	Auxiliary functions	HMC_V6
Version: a 153589 from 18.12.97		657765.49.08	
File: CHAP_9.DOC	650H0000	Sourcefile:07900801.00L	Page 47 / 120

LAM_TRA during RAMP mode.

Proprietary data, company confidential. All rights reserved.
 Contit a titre de secret d'entreprise. Tous droits réservés.
 Comunicado como segredo empresarial. Reservados todos os direitos.
 Confidado como secreto industrial. Nos reservamos todos los derechos.

Weitergabe sowie Vervielfältigung dieser Unterlage, Verwertung und Mitteilung ihres Inhalts nicht gestattet, soweit nicht ausdrücklich zugestanden. Zuwiderhandlungen verpflichten zu Schadensersatz. Alle Rechte vorbehalten, insbesondere für den Fall der Patenterteilung oder GM-Enttragung.

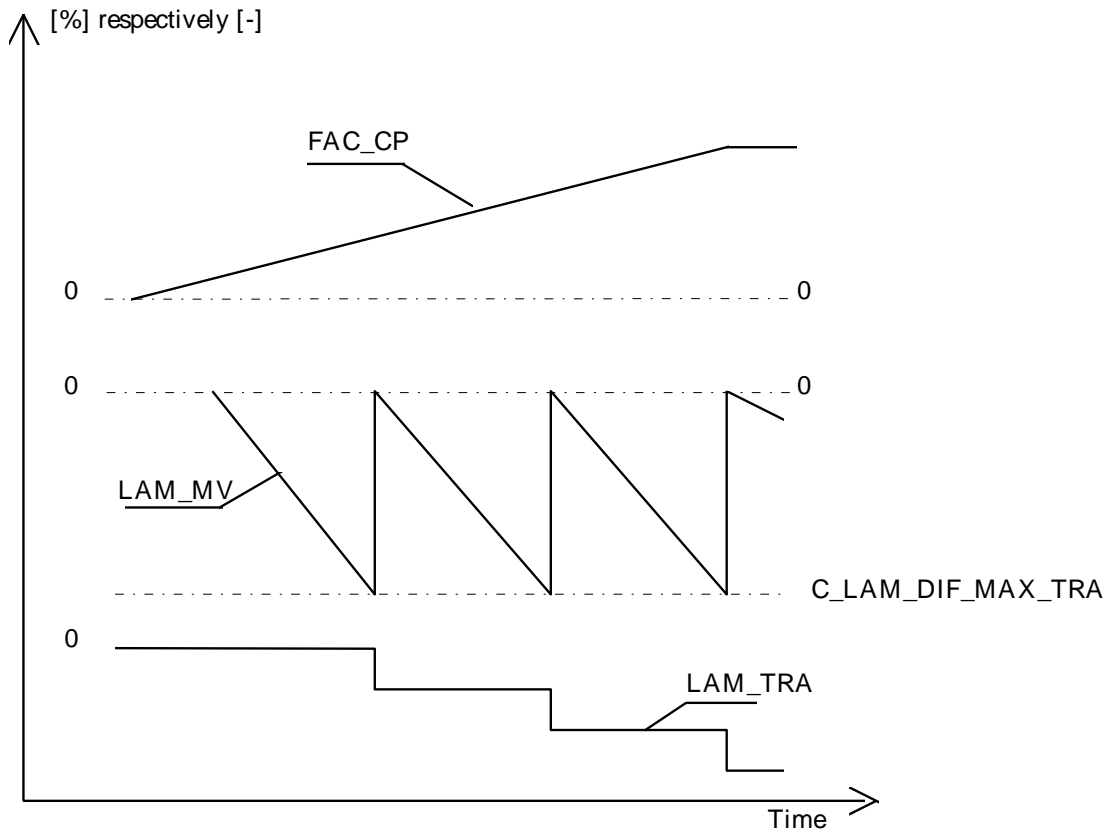

Editor: Müller O.	17-Dec-97	Auxiliary functions	HMC_V6
Version: a 153589 from 18.12.97		657765.49.08	
File: CHAP_9.DOC	650H0000	Sourcefile:07900801.00L	Page 48 / 120

2.2 - Injection time correction LAM_TRA during **NORMAL** operation :

When the charcoal - canister saturation degree changes during **NORMAL** operation, the injection time correction LAM_TRA must be corrected. This change is detected by observing the A/F regulation loop controller mean value LAM_MV at suitable operating points.

For this purpose, the floating average LAM_MV_MMV of the lambda - controller mean value LAM_MV is calculated under the following conditions :

NORMAL operation active

and limited lambda dynamics condition exists for more than one P jump
and $C_MAF_LAM_BOL_TRA < MAF_KGH < C_MAF_LAM_TOL_TRA$
and $CPPWM > 0$
and $IP_LAM_CP_N_32_MAF_ALTI_COR \geq C_LAM_TRA_STATE_MIN$

then At the beginning of **NORMAL** operation :

- LAM_TRA is applied
- Initialisation of LAM_MV_MMV and LAM_MV_BEG with LAM_MV
- Initialisation of LAM_MV_DIF_COR_CP with 0

$$LAM_MV_MMV_{(n)} = LAM_MV_MMV_{(n-1)} + (LAM_MV_{(n)} - LAM_MV_MMV_{(n-1)}) * C_LAM_MV_CRLC$$

During **NORMAL** operation :

- Calculation of LAM_MV_MMV_DIF :

$$LAM_MV_MMV_DIF_{(n)} = LAM_MV_BEG - LAM_MV_MMV_{(n)}$$

- Calculation of LAM_MV_DIF_COR_CP :

$$LAM_MV_DIF_COR_CP_{(n)} = LAM_MV_DIF_COR_CP_{(n-1)} - LAM_MV_MMV_DIF_{(n)}$$

if $|LAM_MV_MMV_DIF_{(n)}| > C_LAM_MV_MMV_DIF_CP$
then $LAM_MV_DIF_CP_{(n)} = LAM_MV_DIF_CP_{(n-1)} - LAM_MV_MMV_DIF_{(n)}$
and LAM_TRA is corrected by applying LAM_MV_DIF_CP_(n) ,
 shifting TI_LAM_(n), LAM_MV_(n) and LAM_MV_MMV_(n).
 So that the result is $LAM_MV_MMV_DIF_{(n)} = 0$.

In this way, the process can repeat itself several times within **NORMAL** operation.

Proprietary data, company confidential. All rights reserved.
 Contient des données confidentielles de la société. Tous droits réservés.
 Comunicado como segredo empresarial. Reservados todos os direitos.
 Confidado como secreto industrial. Nos reservamos todos los derechos.

Weitergabe sowie Vervielfältigung dieser Unterlage, Verwertung und Mitteilung ihres Inhalts ist gestattet, soweit nicht ausdrücklich zugestanden. Zuwiderhandlungen verpflichten zu Schadenersatz. Alle Rechte vorbehalten, insbesondere für den Fall der Patenterteilung oder GM-Entragung.

Editor: Müller O.	17-Dec-97	Auxiliary functions	HMC_V6
Version: a 153589 from 18.12.97		657765.49.08	
File: CHAP_9.DOC	650H0000	Sourcefile:07900801.00L	Page 49 / 120

Limitation :

The total correction of LAM_MV_DIF_CP (LAM_MV_MMV_DIF = LAM_MV_DIF_COR_CP) within one **NORMAL** operation cycle is stored and compared to a limit.

If $|LAM_MV_DIF_COR_CP| > C_LAM_MV_DIF_COR_MAX_CP$
then the **NORMAL** operation state is disabled, and a new determination of the degree of charcoal - canister saturation is required.

2.3 - Injection time correction LAM_TRA during **RAMP** closing :

Beginning with the closing , LAM_TRA is also decremented step by step and the maximum decrement is C_LAM_DIF_MAX_TRA.

a - $|LAM_TRA| \leq C_LAM_DIF_MAX_TRA$

In this case, the injection time correction LAM_TRA is set to 0 just from the beginning of the **RAMP** closing.

b - $|LAM_TRA| > C_LAM_DIF_MAX_TRA$

In this case, the injection time correction LAM_TRA is computed as following :

$$LAM_TRA = (LAM_MV_DIF_CP_{(n)} * IP_LAM_CP_{(0)} / IP_LAM_CP_{(n)}) + C_LAM_DIF_MAX_TRA$$

For the further steps IP_LAM_CP_(n) is updated and LAM_MV_DIF_CP_(n) is set to the new LAM_TRA value.

This results in a deviation of the lambda controller in the positive direction. With the gradually **RAMP** closing, the lambda controller will reach the value LAM_MV_BEG from the beginning of the **LEARNING** mode.

If this value is reached, the LAM_TRA will be decremented in the same way like the first **RAMP** closing.

Latest, if the final duty cycle of the **RAMP** closing is reached, or the **RAMP** mode is finished in any other way, the remaining LAM_TRA value is set to 0.

For each shift of LAM_TRA, the values of LAM_(n) , LAM_MV_(n) , LAM_MV_MMV_(n) are switched in the opposite direction.

Editor: Müller O.	17-Dec-97	Auxiliary functions	HMC_V6
Version: a 153589 from 18.12.97		657765.49.08	
File: CHAP_9.DOC	650H0000	Sourcefile:07900801.00L	Page 50 / 120

Calibration data:

Name	Dim	Hex. limits	Phys. limits	Resol.	Unit
C_MAF_LAM_BOL_TRA	1	0...FFFFH	0...16383.75	0.25	kg / h
MAF low threshold to weight the injection time correction LAM_TRA.					
C_MAF_LAM_TOL_TRA	1	0...FFFFH	0...16383.75	0.25	kg / h
MAF high threshold to weight the injection time correction LAM_TRA.					
C_LAM_MV_CRLC	1	0...FFH	0...0.996	0.0039	-
Correlation factor for LAM_MV_MMV calculation.					
C_LAM_MV_MMV_DIF_CP	1	8000...D000H	0...31.25	0.001275	%
Intermediate threshold for updating injection time correction in NORMAL operation.					
IP_LAM_TRA_LGRD__MAF_KGH	8	01...4000H	0.000015...0.25	0.000015	-
Gradient limitation for LAM_TRA.					
IP_LAM_CP__N_32__MAF_ALTI_COR	7 x 8	01...FFFFH	0...1	0.000015 3	-
Weighting factor for the injection time correction LAM_TRA.					
IP_LAM_CP__N_32__MAF	7 x 8	01...FFFFH	0...1	0.000015 3	-
Weighting factor for the injection time correction LAM_TRA.					

Proprietary data, company confidential. All rights reserved.
 Contient des informations confidentielles. Tous droits réservés.
 Comunicado como secreto empresarial. Reservados todos los derechos.
 Confidado como secreto industrial. Nos reservamos todos los derechos.

Weitergabe sowie Vervielfältigung dieser Unterlage, Verwertung und Mitteilung ihres Inhalts nicht gestattet, soweit nicht ausdrücklich zugestanden. Zuwiderhandlungen verpflichten zu Schadensersatz. Alle Rechte vorbehalten, insbesondere für den Fall der Patenterteilung oder GM-Eintragung.

Editor: Müller O.	17-Dec-97	Auxiliary functions	HMC_V6
Version: a 153589 from 18.12.97		657765.49.08	
File: CHAP_9.DOC	650H0000	Sourcefile:07900801.00L	Page 51 / 120

4.11 Influence of the evaporative emission control on lambda adaptation

Output data:

Name	Mode	Hex. limits	Phys. limits	Resol.	Unit
LV_AUTH_LAM_AD_CP	V	0...01H	0...1	1	-
Boolean information for lambda adaptation out of LEARNING mode.					
LV_AUTH_LAM_1_AD_LEARN_CP	V	0...01H	0...1	1	-
Boolean information for lambda adaptation during LEARNING mode with CPPWM = 0 for lambda controller n° 1.					
LV_AUTH_LAM_2_AD_LEARN_CP	V	0...01H	0...1	1	-
Boolean information for lambda adaptation during LEARNING mode with CPPWM = 0 for lambda controller n° 2.					

Input data:

LV_STB_PHA_CP	LV_MIN_PHA_CP	LV_NORMAL_PHA_CP	LV_SLOP_CP
LV_LEARN_CP	CPPWM		

FUNCTION DESCRIPTION:

These boolean information are in direct relationship with the determination of the correlation factor C_TI_AD_COR_CRLC_xx for lambda adaptation calculation.

If the **LEARNING** mode is active, during stabilisation of the lambda controller, lambda adaptation can be performed only if CPPWM = 0.
In this case, LV_AUTH_LAM_i_AD_LEARN_CP is set to 1.

In the other modes, out of **LEARNING** mode, the flag LV_AUTH_LAM_AD_CP is set to 1 and LV_AUTH_LAM_i_AD_LEARN_CP is set to 0.

Proprietary data, company confidential. All rights reserved. Contient des informations confidentielles. Tous droits réservés. Comunicado como segredo empresarial. Reservados todos os direitos. Confidado como secreto industrial. Nos reservamos todos los derechos.

Weitergabe sowie Vervielfältigung dieser Unterlage, Verbreitung und Mitteilung ihres Inhalts nicht gestattet, soweit nicht ausdrücklich zugestanden. Zuwiderhandlungen verpflichten zu Schadensersatz. Alle Rechte vorbehalten, insbesondere für den Fall der Patenterteilung oder GM-Entragung.

Editor: Müller O.	17-Dec-97	Auxiliary functions	HMC_V6
Version: a 153589 from 18.12.97		657765.49.08	
File: CHAP_9.DOC	650H0000	Sourcefile:07900801.00L	Page 52 / 120

5 Cooling and condenser fans control

Output data:

Name	Mode	Hex. limits	Phys. limits	Resol.	Unit
STATE_CFA	V	0...03H	0...3	1	-
Cooling and condenser fans state (0,1,2,3).					
STATE_CFA_IS	V	0...03H	0...3	1	-
Cooling and condenser fans state for idle - charge actuator opening corrections (0,1,2,3).					
STATE_CFA_1	-	0...03H	0...3	1	-
Intermediate cooling and condenser fans state for STATE_CFA and STATE_CFA_IS calculation (0,1,2,3)					
LV_RLY_FAN_L	V	0...01H	0...1	1	-
Logic output from ECU for cooling and condenser fans control (LOW) - (OFF / ON).					
LV_RLY_FAN_H	V	0...01H	0...1	1	-
Logic output from ECU for cooling and condenser fans control (HIGH) - (OFF / ON).					

Input data:

VS_STATE_CFA	TCO	LV_ACIN	LV_IGK
LV_ES	TIA	LV_ACCIN	LV_IS
LV_TCO_ERR	LV_PRS_ACC	LV_RLY_ACCOUT	LV_ES

FUNCTION DESCRIPTION:

General information:

The cooling and condenser fans activation is controlled by the ECU, using two logic outputs : LV_RLY_FAN_L (LOW) and LV_RLY_FAN_H (HIGH)

They are set **ON** or **OFF** depending on :

- coolant temperature TCO
- air condition request LV_ACCIN
- vehicle speed state VS_STATE_CFA
- Pressure in the A/C circuit LV_PRS_ACC

Each fan is controlled with 3 speeds : **LOW, MIDDLE, HIGH**

The computation of the variable STATE_CFA determines the level of the two logic outputs LV_RLY_FAN_L and LV_RLY_FAN_H. The fan speed depends on these outputs and the air condition request switch state (LV_ACCIN).

If the pressure in the A/C circuit is high (LV_PRS_ACC = 1) then cooling and condenser fans speed is set to high in order to fastly decrease the pressure.

The application recurrence is **40 msec**.

Editor: Müller O.	17-Dec-97	Auxiliary functions	HMC_V6
Version: a 153589 from 18.12.97		657765.49.08	
File: CHAP_9.DOC	650H0000	Sourcefile:07900901.00I	Page 53 / 120

Description:

Proprietary data, company confidential. All rights reserved.
 Contient des informations confidentielles. Tous droits réservés.
 Comunicado como segredo empresarial. Reservados todos os direitos.
 Confidado como secreto industrial. Nos reservamos todos los derechos.

		LV_RLY_FAN_H						
		0			1			
LV_RLY_FAN_L	0	OFF		OFF	MIDDLE		MIDDLE	0
	1	OFF	0	OFF	MIDDLE	2	MIDDLE	1
LV_RLY_FAN_L	0	LOW		OFF	HIGH		MIDDLE	0
	1	LOW	1	LOW	HIGH	3	HIGH	1
		Cooling Fan	STATE_CFA (IS)	Condenser Fan	Cooling Fan	STATE_CFA (IS)	Condenser Fan	

The states of LV_RLY_FAN_L, LV_RLY_FAN_H, LV_ACCIN correspond to **logical** state :

- Logical state **0** ⇔ **OFF** ⇔ **+12 Volt** present on the corresponding pin - out of the ECU
- Logical state **1** ⇔ **ON** ⇔ **Ground** present on the corresponding pin - out of the ECU

Remark :

- LV_ACIN : air condition selected
- LV_ACCIN : air condition requested
- LV_RLY_ACCOUT : air condition compressor active.

Weitergabe sowie Vervielfältigung dieser Unterlage, Verwertung und Mitteilung ihres Inhalts ist gestattet, soweit nicht ausdrücklich zugestanden. Zuwiderhandlungen verpflichten zu Schadensersatz. Alle Rechte vorbehalten, insbesondere für den Fall der Patenterteilung oder GM-Enttragung

Editor: Müller O.	17-Dec-97	Auxiliary functions	HMC_V6
Version: a 153589 from 18.12.97		657765.49.08	
File: CHAP_9.DOC	650H0000	Sourcefile:07900901.00I	Page 54 / 120

Application conditions:**- STATE_CFA_IS calculation:**

STATE_CFA_IS is used to activate the idle speed valve corrections.

```

If Engine operating state LV_ES = 1
  and TCO > C_TCO_ON_CFA_ES
  then A timer is started and STATE_CFA_IS = STATE_CFA_1
        When the timer has reached ID_CFA_ON_ES__TIA__TCO,
        STATE_CFA_IS is set back to 0.

  else
    If Engine operating state LV_ST = 1
      then STATE_CFA_IS = 0 during C_T_OFF_CFA_ST seconds
    else
      If LV_TCO_ERR = 1 (error currently present on coolant
        temperature sensor)
        or ( LV_PRS_ACC = 1 and LV_ACIN = 1 )
        then STATE_CFA_IS = 3 (high pressure in A/C circuit)
        else STATE_CFA_IS = STATE_CFA_1 (low pressure in A/C
          circuit)

      Endif
    Endif
  Endif.

```

- STATE_CFA calculation:

STATE_CFA is equal to STATE_CFA_IS except if STATE_CFA_IS value is updated. Then a time delay is applied to increase or decrease STATE_CFA.

```

If STATE_CFA_IS (n) = STATE_CFA_IS (n-1) (STATE_CFA_IS stays constant)
  then STATE_CFA = STATE_CFA_IS
  else
    If STATE_CFA_IS (n) > STATE_CFA_IS (n-1) (STATE_CFA_IS increases)
      then STATE_CFA = STATE_CFA_IS after the time delay C_T_RTD_INC_x_CFA
        (If LV_PRS_ACC = 1
          then C_T_RTD_INC_x_CFA = C_T_RTD_INC_1_CFA
          else C_T_RTD_INC_x_CFA = C_T_RTD_INC_0_CFA
        )
    else (STATE_CFA_IS decreases)
      STATE_CFA = STATE_CFA_IS after the time delay C_T_RTD_DEC_CFA

```

Editor: Müller O.	17-Dec-97	Auxiliary functions	HMC_V6
Version: a 153589 from 18.12.97		657765.49.08	
File: CHAP_9.DOC	650H0000	Sourcefile:07900901.00I	Page 55 / 120

- STATE_CFA_1 calculation:

1 - LV_ACCIN = 0 and VS_STATE_CFA = 0

1.1 - **If** LV_ACCIN or VS_STATE_CFA values were different just before **then**

If $TCO < C_TCO_3_CFA$
then $STATE_CFA_1 = 0$

If $C_TCO_3_CFA \leq TCO < C_TCO_4_CFA$
then $STATE_CFA_1 = 1$

If $C_TCO_4_CFA \leq TCO < C_TCO_5_CFA$
then $STATE_CFA_1 = 2$

If $TCO \geq C_TCO_5_CFA$
then $STATE_CFA_1 = 3$

1.2 - **If** LV_ACCIN and VS_STATE_CFA values remain the same **then**

Conditions to increase STATE_CFA_1 :

If $TCO \geq C_TCO_3_CFA$ **and** $STATE_CFA_1 = 0$
then $STATE_CFA_1 = 1$

If $TCO \geq C_TCO_4_CFA$ **and** $STATE_CFA_1 = 1$
then $STATE_CFA_1 = 2$

If $TCO \geq C_TCO_5_CFA$ **and** $STATE_CFA_1 = 2$
then $STATE_CFA_1 = 3$

Conditions to decrease STATE_CFA_1 :

If $TCO \leq (C_TCO_3_CFA - C_TCO_HYS_1_CFA)$ **and** $STATE_CFA_1 = 1$
then $STATE_CFA_1 = 0$

If $TCO \leq (C_TCO_4_CFA - C_TCO_HYS_2_CFA)$ **and** $STATE_CFA_1 = 2$
then $STATE_CFA_1 = 1$

If $TCO \leq (C_TCO_5_CFA - C_TCO_HYS_3_CFA)$ **and** $STATE_CFA_1 = 3$
then $STATE_CFA_1 = 2$

Editor: Müller O.	17-Dec-97	Auxiliary functions	HMC_V6
Version: a 153589 from 18.12.97		657765.49.08	
File: CHAP_9.DOC	650H0000	Sourcefile:07900901.00I	Page 56 / 120

2 - LV_ACCIN = 0 and VS_STATE_CFA = 1

2.1 - If LV_ACCIN or VS_STATE_CFA values were different just before
then

If TCO < C_TCO_2_CFA
then STATE_CFA_1 = 0

If C_TCO_2_CFA ≤ TCO < C_TCO_4_CFA
then STATE_CFA_1 = 1

If TCO ≥ C_TCO_4_CFA
then STATE_CFA_1 = 3

2.2 - If LV_ACCIN and VS_STATE_CFA values remain the same
then

Conditions to increase STATE_CFA_1 :

If TCO ≥ C_TCO_2_CFA **and** STATE_CFA_1 = 0
then STATE_CFA_1 = 1

If TCO ≥ C_TCO_4_CFA **and** STATE_CFA_1 = 1
then STATE_CFA_1 = 3

Conditions to decrease STATE_CFA_1 :

If TCO ≤ (C_TCO_2_CFA - C_TCO_HYS_1_CFA) **and** STATE_CFA_1 = 1
then STATE_CFA_1 = 0

If TCO ≤ (C_TCO_4_CFA - C_TCO_HYS_2_CFA) **and** STATE_CFA_1 = 3
then STATE_CFA_1 = 1

Editor:	Müller O.	17-Dec-97	Auxiliary functions	HMC_V6
Version:	a 153589 from 18.12.97		657765.49.08	
File:	CHAP_9.DOC	650H0000	Sourcefile:07900901.00I	Page 57 / 120

3 - LV_ACCIN = 0 and VS_STATE_CFA = 2

3.1 - **If** LV_ACCIN or VS_STATE_CFA values were different just before
then

If TCO < C_TCO_4_CFA
then STATE_CFA_1 = 0

If TCO ≥ C_TCO_4_CFA
then STATE_CFA_1 = 3

3.2 - **If** LV_ACCIN and VS_STATE_CFA values remain the same
then

Conditions to increase STATE_CFA_1 :

If TCO ≥ C_TCO_4_CFA **and** STATE_CFA_1 = 0
then STATE_CFA_1 = 3

Conditions to decrease STATE_CFA_1 :

If TCO ≤ (C_TCO_4_CFA - C_TCO_HYS_2_CFA) **and** STATE_CFA_1 = 3
then STATE_CFA_1 = 0

Editor:	Müller O.	17-Dec-97	Auxiliary functions	HMC_V6
Version:	a 153589 from 18.12.97		657765.49.08	
File:	CHAP_9.DOC	650H0000	Sourcefile:07900901.00I	Page 58 / 120

4 - LV_ACCIN = 1 and VS_STATE_CFA = 0

4.1 - If LV_ACCIN or VS_STATE_CFA values were different just before.
then

If $TCO < C_TCO_1_CFA$
then $STATE_CFA_1 = 0$

If $C_TCO_1_CFA \leq TCO < C_TCO_4_CFA$
then $STATE_CFA_1 = 1$

If $C_TCO_4_CFA \leq TCO < C_TCO_5_CFA$
then $STATE_CFA_1 = 2$

If $TCO \geq C_TCO_5_CFA$
then $STATE_CFA_1 = 3$

4.2 - If LV_ACCIN and VS_STATE_CFA values remain the same
then

Conditions to increase STATE_CFA_1 :

If $TCO \geq C_TCO_1_CFA$ and $STATE_CFA_1 = 0$
then $STATE_CFA_1 = 1$

If $TCO \geq C_TCO_4_CFA$ and $STATE_CFA_1 = 1$
then $STATE_CFA_1 = 2$

If $TCO \geq C_TCO_5_CFA$ and $STATE_CFA_1 = 2$
then $STATE_CFA_1 = 3$

Conditions to decrease STATE_CFA_1 :

If $TCO \leq C_TCO_1_CFA$ and $STATE_CFA_1 = 1$
then $STATE_CFA_1 = 0$

If $TCO \leq (C_TCO_4_CFA - C_TCO_HYS_2_CFA)$ and $STATE_CFA_1 = 2$
then $STATE_CFA_1 = 1$

If $TCO \leq (C_TCO_5_CFA - C_TCO_HYS_4_CFA)$ and $STATE_CFA_1 = 3$
then $STATE_CFA_1 = 2$

Editor:	Müller O.	17-Dec-97	Auxiliary functions	HMC_V6
Version:	a 153589 from 18.12.97		657765.49.08	
File:	CHAP_9.DOC	650H0000	Sourcefile:07900901.00I	Page 59 / 120

5 - LV_ACCIN = 1 and VS_STATE_CFA = 1

5.1 - **If** LV_ACCIN or VS_STATE_CFA were different just before
then

If $TCO < C_TCO_1_CFA$
then $STATE_CFA_1 = 0$

If $C_TCO_1_CFA \leq TCO < C_TCO_4_CFA$
then $STATE_CFA_1 = 1$

If $TCO \geq C_TCO_4_CFA$
then $STATE_CFA_1 = 3$

5.2 - **If** LV_ACCIN and VS_STATE_CFA remain the same
then

Conditions to increase STATE_CFA_1 :

If $TCO \geq C_TCO_1_CFA$ **and** $STATE_CFA_1 = 0$
then $STATE_CFA_1 = 1$

If $TCO \geq C_TCO_4_CFA$ **and** $STATE_CFA_1 = 1$
then $STATE_CFA_1 = 3$

Conditions to decrease STATE_CFA_1 :

If $TCO \leq (C_TCO_4_CFA - C_TCO_HYS_2_CFA)$ **and** $STATE_CFA_1 = 3$
then $STATE_CFA_1 = 1$

If $TCO \leq C_TCO_1_CFA$ **and** $STATE_CFA_1 = 1$
then $STATE_CFA_1 = 0$

Editor:	Müller O.	17-Dec-97	Auxiliary functions	HMC_V6
Version:	a 153589 from 18.12.97		657765.49.08	
File:	CHAP_9.DOC	650H0000	Sourcefile:07900901.00I	Page 60 / 120

Proprietary data, company confidential. All rights reserved.
 Contit a titre de secret d'entreprise. Tous droits réservés.
 Comunicado como secreto empresarial. Reservados todos os direitos.
 Confidado como secreto industrial. Nos reservamos todos los derechos.

Weitergabe sowie Vervielfältigung dieser Unterlage, Verwertung und Mitteilung ihres Inhalts nicht gestattet, soweit nicht ausdrücklich zugestanden. Zuwiderhandlungen verpflichten zu Schadensersatz. Alle Rechte vorbehalten, insbesondere für den Fall der Patenterteilung oder GM-Enttragung.

6 - LV_ACCIN = 1 and VS_STATE_CFA = 2

6.1 - **If** LV_ACCIN or VS_STATE_CFA values were different just before
then

If TCO < C_TCO_4_CFA
then STATE_CFA_1 = 0

If TCO ≥ C_TCO_4_CFA
then STATE_CFA_1 = 3

6.2 - **If** LV_ACCIN and VS_STATE_CFA values remain the same
then

Conditions to increase STATE_CFA_1 :

If TCO ≥ C_TCO_4_CFA **and** STATE_CFA_1 = 0
then STATE_CFA_1 = 3

Conditions to decrease STATE_CFA_1 :

If TCO ≤ (C_TCO_4_CFA - C_TCO_HYS_2_CFA) **and** STATE_CFA_1 = 3
then STATE_CFA_1 = 0

Remark :

$C_TCO_1_CFA \leq C_TCO_2_CFA \leq C_TCO_3_CFA \leq C_TCO_4_CFA \leq C_TCO_5_CFA$

Editor:	Müller O.	17-Dec-97	Auxiliary functions	HMC_V6
Version:	a 153589 from 18.12.97		657765.49.08	
File:	CHAP_9.DOC	650H0000	Sourcefile:07900901.00I	Page 61 / 120

Calibration data:

Name	Dim	Hex. limits	Phys. limits	Resol.	Unit
C_TCO_1_CFA	1	0...FFH	-48...142,5	0,75	°C
Coolant temperature threshold for fans control.					
C_TCO_2_CFA	1	0...FFH	-48...142,5	0,75	°C
Coolant temperature threshold for fans control.					
C_TCO_3_CFA	1	0...FFH	-48...142,5	0,75	°C
Coolant temperature threshold for fans control.					
C_TCO_4_CFA	1	0...FFH	-48...142,5	0,75	°C
Coolant temperature threshold for fans control.					
C_TCO_5_CFA	1	0...FFH	-48...142,5	0,75	°C
Coolant temperature threshold for fans control.					
C_TCO_HYS_1_CFA	1	0...FFH	0...191,25	0,75	°C
Coolant temperature hysteresis for STATE_CFA transition 1->0.					
C_TCO_HYS_2_CFA	1	0...FFH	0...191,25	0,75	°C
Coolant temperature hysteresis for STATE_CFA transition 2->1 or 2->0.					
C_TCO_HYS_3_CFA	1	0...FFH	0...191,25	0,75	°C
Coolant temperature hysteresis for STATE_CFA transition 3->2.					
C_TCO_HYS_4_CFA	1	0...FFH	0...191,25	0,75	°C
Coolant temperature hysteresis for STATE_CFA transition 3->2.					
C_T_RTD_INC_0_CFA	1	0...FFH	0...10,24	0,040	sec
Time delay before increasing STATE_CFA if LV_PRS_ACC = 0					
C_T_RTD_INC_1_CFA	1	0...FFH	0...10,24	0,040	sec
Time delay before increasing STATE_CFA if LV_PRS_ACC = 1					
C_T_RTD_DEC_CFA	1	0...FFH	0...10,24	0,040	sec
Time delay before decreasing STATE_CFA					
C_T_OFF_CFA_ST	1	0...FFH	0...255	1	sec
Time to deactivate fans during engine operating state start (LV_ST) detection.					
C_TCO_ON_CFA_ES	1	0...FFH	-48...142,5	0,75	°C
Minimum coolant temperature to start fans under power latch.					
ID_ON_CFA_ES_TCO_TIA	5 x 5	0...FFH	0...255	1	sec
Activation duration of the fans under power latch.					

Proprietary data, company confidential. All rights reserved.
 Contine a titre de secret d'entreprise. Tous droits réservés.
 Comunicado como segredo empresarial. Reservados todos os direitos.
 Confidado como secreto industrial. Nos reservamos todos los derechos.

Weitergabe sowie Vervielfältigung dieser Unterlage, Verwertung und Mitteilung ihres Inhalts ist gestattet, soweit nicht ausdrücklich zugestanden. Zuwiderhandlungen verpflichten zu Schadensersatz. Alle Rechte vorbehalten, insbesondere für den Fall der Patenterteilung oder GM-Entragung.

Editor: Müller O.	17-Dec-97	Auxiliary functions	HMC_V6
Version: a 153589 from 18.12.97		657765.49.08	
File: CHAP_9.DOC	650H0000	Sourcefile:07900901.001	Page 62 / 120

Proprietary data, company confidential. All rights reserved.
 Contitit a titre de secret d'entreprise. Tous droits réservés.
 Comunicado como segredo empresarial. Reservados todos os direitos.
 Confidado como secreto industrial. Nos reservamos todos los derechos.

Weitergabe sowie Vervielfältigung dieser Unterlage, Verwertung und Mitteilung ihres Inhalts nicht gestattet, soweit nicht ausdrücklich zugestanden. Zuwiderhandlungen verpflichten zu Schadensersatz. Alle Rechte vorbehalten, insbesondere für den Fall der Patenterteilung oder GM-Enttragung

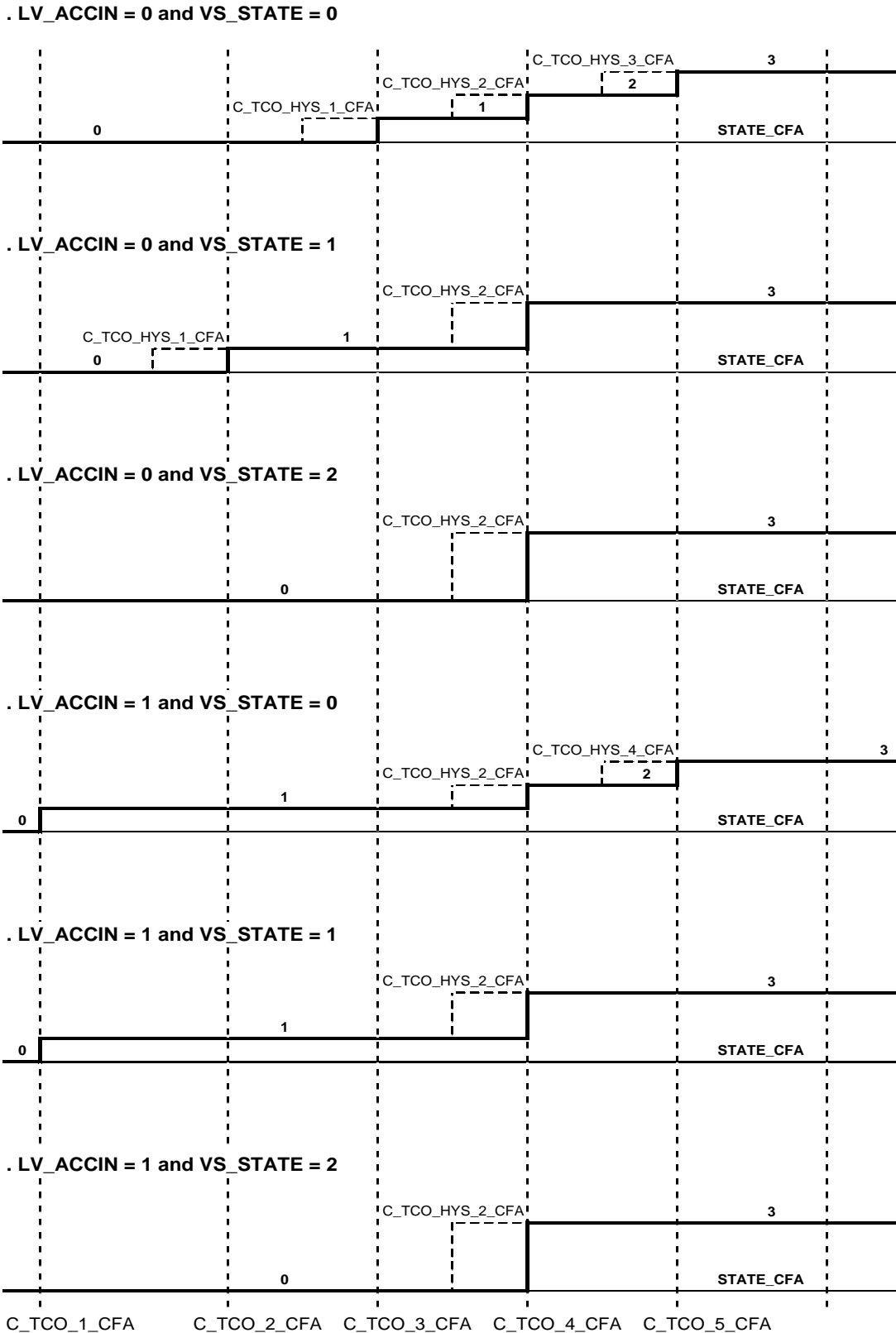

Editor: Müller O.	17-Dec-97	Auxiliary functions	HMC_V6
Version: a 153589 from 18.12.97		657765.49.08	
File: CHAP_9.DOC	650H0000	Sourcefile:07900901.00I	Page 63 / 120

6 Engine speed limitation

Output data:

Name	Mode	Hex. limits	Phys. limits	Resol.	Unit
LV_N_MAX	V	0...01H	0...1	1	-
Boolean for engine speed limitation					
LV_N_MAX_FCUT	V	0...01H	0...1	1	-
Boolean for engine speed limitation in case of vehicle stopped					
N_MAX_THD	V	0...FFH	0...8160	32	rpm
Maximum engine speed threshold for cylinder shut - off.					
N_MAX_MAX	V	0...FFH	0...8160	32	rpm
Maximum engine speed threshold for immediate cylinders cut - off.					
PAT_INH_IV_N_MAX	V	0...maxH	0...max	1	-
Fuel shut-off pattern index in case of maximum engine speed - max = NC_INI_INH_SWI_IV_SHIFT_NR.					

Input data:

LV_ISA_i_ERR	LV_VS_ERR	TPS	N_32
LV_MAF_ERR	VS	LV_ISA_MECHA_ERR	LV_TPS_ERR
NC_INI_INH_SWI_IV_SHIFT_NR	LV_CT	TCO	LV_DRI
LV_CRK_ERR	LV_TCO_ERR	LV_VS_ERR	LV_TPS_PLAUS_ERR
LV_MAF_PLAUS_ERR	LV_CRK_ERR_LIH		

FUNCTION DESCRIPTION:

General information:

This fuel shut - off allows to protect the engine against overspeed.

There are two kinds of overspeed fuel shut-off :

- 1 - the injectors are shut - off progressively, according to the cylinder shut - off pattern PAT_INH_IV_N_MAX. This corresponds to engine speed threshold N_MAX_THD.
N_MAX_THD is defined according to the present failures (ISAPWM,TPS, MAF...)
- 2 - the injectors are cut-off immediately. This corresponds to engine speed threshold N_MAX_MAX. Injectors are shut-off immediately if progressive fuel shut-off was no sufficient (engine speed still increasing) or if engine speed stays high during a long time with vehicle stopped.

Editor: Müller O.	17-Dec-97	Auxiliary functions	HMC_V6
Version: a 153589 from 18.12.97		657765.49.08	
File: CHAP_9.DOC	650H0000	Sourcefile:07901E01.00B	Page 64 / 120

Application conditions:

1) LV_N_MAX_FCUT determination :

In order to prevent the catalyst system from over-heating, it is detected if engine speed stays high with vehicle stopped during a pre-defined time.

At each engine Start, LV_N_MAX_FCUT is initialised to 0.

LV_N_MAX_FCUT is set to 1 **if** during C_T_N_MAX_FCUT seconds:

- LV_CT = 0
- **and** VS = 0
- **and** TCO > C_TCO_N_MAX_FCUT
- **and** N_32 > C_N_FCUT
- **and** LV_DRI = 0
- **and** LV_CRK_ERR = 0
- **and** LV_TCO_ERR = 0
- **and** LV_VS_ERR = 0

LV_N_MAX_FCUT is set back to 0 **if**:

- LV_CT = 1
- **or** VS > 0
- **or** TCO < C_TCO_N_MAX_FCUT
- **or** LV_DRI = 1
- **or** LV_CRK_ERR = 1
- **or** LV_TCO_ERR = 1
- **or** LV_VS_ERR = 1

2) N_MAX_MAX calculation :

If there is a risk to damage the catalyst, maximum engine speed is reduced.

If LV_N_MAX_FCUT = 1

then N_MAX_MAX = C_N_MAX_FCUT

else N_MAX_MAX = C_N_MAX_MAX

Editor:	Müller O.	17-Dec-97	Auxiliary functions	HMC_V6
Version:	a 153589 from 18.12.97		657765.49.08	
File:	CHAP_9.DOC	650H0000	Sourcefile:07901E01.00B	Page 65 / 120

Proprietary data, company confidential. All rights reserved.
 Contine a titre de secret d'entreprise. Tous droits réservés.
 Comunicado como segredo empresarial. Reservados todos os direitos.
 Confidado como secreto industrial. Nos reservamos todos los derechos.

Weitergabe sowie Vervielfältigung dieser Unterlage, Verwertung und Mitteilung ihres Inhalts nicht gestattet, soweit nicht ausdrücklich zugestanden. Zuwiderhandlungen verpflichten zu Schadenersatz. Alle Rechte vorbehalten, insbesondere für den Fall der Patenterteilung oder GM-Entragung.

3) N_MAX_THD calculation :

Normal maximum engine speed can be modified due some present failures.

- **If** (LV_ISA_1_ERR = 1 **or** LV_ISA_MECHA_ERR = 1)
*(Idle speed actuator coil 1 - only if short to ground detected or
 Idle speed actuator mechanical error - only if ISA stuck open detected)*
 - then**
 - if** (LV_TPS_ERR = 1 **or** LV_TPS_PLAUS_ERR = 1)
(an error is currently present on the throttle position sensor)
 - then** N_MAX_THD_1 = C_N_MAX_TPS_ISAPWM_DIAG
 - else** N_MAX_THD_1 = IP_N_MAX_ISAPWM_DIAG__TPS
 - else** N_MAX_THD_1 = 8160 rpm
 - **If** (LV_TPS_ERR = 1 **or** LV_TPS_PLAUS_ERR = 1)
and (LV_MAF_ERR = 1 **or** LV_MAF_PLAUS_ERR = 1)
*(an error is currently present on the throttle position sensor and on the mass air
 flow sensor)*
 - then** N_MAX_THD_2 = C_N_MAX_TPS_DIAG
 - else** N_MAX_THD_2 = 8160 rpm
 - **If** LV_VS_ERR = 1
(an error is currently present on vehicle speed)
 - then** N_MAX_THD_3 = C_N_MAX_VS_DIAG
 - else** N_MAX_THD_3 = 8160 rpm
 - **If** LV_CRK_ERR_LIH = 1
(Limp home for crankshaft sensor active)
 - then** N_MAX_THD_4 = C_N_MAX_CRK_DIAG
 - else** N_MAX_THD_4 = 8160 rpm

$$N_MAX_THD = \text{Min.} (\begin{array}{l} N_MAX_THD_1, \\ N_MAX_THD_2, \\ N_MAX_THD_3, \\ N_MAX_THD_4, \\ N_MAX_MAX, \\ C_N_MAX \end{array})$$

Editor: Müller O.	17-Dec-97	Auxiliary functions	HMC_V6
Version: a 153589 from 18.12.97		657765.49.08	
File: CHAP_9.DOC	650H0000	Sourcefile:07901E01.00B	Page 66 / 120

Proprietary data, company confidential. All rights reserved.
 Contit a titre de secret d'entreprise. Tous droits réservés.
 Comunicado como segredo empresarial. Reservados todos os direitos.
 Confidado como secreto industrial. Nos reservamos todos los derechos.

Weitergabe sowie Vervielfältigung dieser Unterlage, Verwertung und Mitteilung ihres Inhalts nicht gestattet, soweit nicht ausdrücklich zugestanden. Zuwiderhandlungen verpflichten zu Schadensersatz. Alle Rechte vorbehalten, insbesondere für den Fall der Patenterteilung oder GM-Enttragung.

4) Progressive cylinder shut-off in case of over speed :

If $N_{32} > N_{MAX_THD}$

then :

- LV_N_MAX is set to 1
- Cylinder shut-off level (PAT_INH_IV_N_MAX) is increased by 1 each ID_N_MAX_CYCNR__VS cycles **until:**
- $N_{32} < N_{MAX_THD} - C_{N_MAX_HYS}$
- **or** PAT_INH_IV_N_MAX reaches its maximum value (13)

5) Immediate cylinder fuel cut-off in case of over speed :

If $N_{32} > N_{MAX_MAX}$

then :

- LV_N_MAX is set to 1
- All the injectors are cut-off immediately (PAT_INH_IV_N_MAX = 13)

6) Progressive cylinders rewetting

If $N_{32} < N_{MAX_THD} - C_{N_MAX_HYS}$

and LV_N_MAX_FCUT = 0

then :

- Cylinder shut - off level (PAT_INH_IV_N_MAX) is decreased by 1 each ID_N_MAX_CYCNR__VS cycles until it reaches 0
- LV_N_MAX is set back to 0 when PAT_INH_IV_N_MAX = 0

7) Immediate cylinders rewetting

If $N_{32} < N_{MAX_THD} - C_{N_MAX_HYS_MAX}$

then :

- Cylinder shut - off level (PAT_INH_IV_N_MAX) is set to 0
- LV_N_MAX is set to 0

Editor: Müller O.	17-Dec-97	Auxiliary functions	HMC_V6
Version: a 153589 from 18.12.97		657765.49.08	
File: CHAP_9.DOC	650H0000	Sourcefile:07901E01.00B	Page 67 / 120

Calibration data:

Name	Dim	Hex. limits	Phys. limits	Resol.	Unit
C_N_MAX	1	0...FFH	0...8160	32	rpm
Engine speed threshold for engine speed limitation (fuel shut - off cylinder by cylinder).					
C_N_MAX_MAX	1	0...FFH	0...8160	32	rpm
Engine speed threshold for engine speed limitation (fuel cut - off all cylinders) if LV_N_MAX_FCUT = 0					
C_N_MAX_HYS	1	0...FFH	0...8160	32	rpm.
Engine speed hysteresis to enable again the injection.					
C_N_MAX_HYS_MAX	1	0...FFH	0...8160	32	rpm
Engine speed hysteresis to enable all the injectors.					
C_N_MAX_TPS_DIAG	1	0...FFH	0...8160	32	rpm
Maximum engine speed (limitation) in case of simultaneous failure on TPS and MAF.					
C_N_MAX_TPS_ISAPWM_DIAG	1	0...FFH	0...8160	32	rpm
Maximum engine speed (limitation) in case of error currently present on ISA and TPS.					
IP_N_MAX_ISAPWM_DIAG_TPS	3	0...FFH	0...8160	32	rpm
Maximum engine speed (limitation) in case of error currently present on ISA.					
C_N_MAX_VS_DIAG	1	0...FFH	0...8160	32	rpm
Maximum engine speed (limitation) in case of error currently present on VS signal.					
C_N_MAX_CRK_DIAG	1	0...FFH	0...8160	32	rpm
Maximum engine speed (limitation) in case of crankshaft sensor Limp-Home active.					
ID_N_MAX_CYCNR__VS	5	01...FFH	1...255	1	-
Number of cycles to increase by 1 the cylinder shut - off level in case of over speed fuel shut - off.					
C_T_N_MAX_FCUT	-	01...FFFFH	0,1...6553,5	0,1	sec.
Time to detect LV_N_MAX_FCUT					
C_TCO_N_MAX_FCUT	-	00...FEH	-48...142,5	0,75	°C
Minimum coolant temperature to detect LV_N_MAX_FCUT					
C_N_FCUT	-	00...FFH	0...8160	32	rpm
Minimum engine speed to detect LV_N_MAX_FCUT					
C_N_MAX_FCUT	-	00...FFH	0...8160	32	rpm
Engine speed threshold for engine speed limitation (fuel cut - off all cylinders) if LV_N_MAX_FCUT = 1					

Proprietary data, company confidential. All rights reserved.
 Contit a titre de secret d'entreprise. Tous droits réservés.
 Comunicado como segredo empresarial. Reservados todos os direitos.
 Confidado como secreto industrial. Nos reservamos todos los derechos.

Weitergabe sowie Vervielfältigung dieser Unterlage, Verwertung und Mitteilung ihres Inhalts nicht gestattet, soweit nicht ausdrücklich zugestanden. Zuwiderhandlungen verpflichten zu Schadenersatz. Alle Rechte vorbehalten, insbesondere für den Fall der Patenterteilung oder GM-Enttragung.

Editor: Müller O.	17-Dec-97	Auxiliary functions	HMC_V6
Version: a 153589 from 18.12.97		657765.49.08	
File: CHAP_9.DOC	650H0000	Sourcefile:07901E01.00B	Page 68 / 120

7 Vehicle speed limitation

Output data:

Name	Mode	Hex. limits	Phys. limits	Resol.	Unit
LV_VS_MAX	V	0...01H	0...1	1	-
Boolean for vehicle speed limitation (Passive / Active).					
LV_OPL_VS_MAX	V	0...01H	0...1	1	-
Boolean for A/F regulation loop opened because of vehicle speed limitation (Passive / Active).					
PAT_INH_IV_VS_MAX	V	0...maxH	0...max	1	-
Fuel shut-off pattern index in case of vehicle speed limitation - max = NC_INI_INH_SWI_IV_SHIFT_NR.					

Input data:

VS	NC_INI_INH_SWI_IV_SHIFT_NR	LV_LSCL_1	N_32
C_TI_VS_MAX_COR	LV_LSCL_2	VS_MAX	

FUNCTION DESCRIPTION:

General information:

If the vehicle speed exceeds the vehicle speed limitation, the following actions are taken with the priorities :

- 1 - deactivation of all enrichments.
- 2 - A/F regulation loop opened and mixture leaning
- 3 - injectors shut - off progressively according to the cylinder shut - off pattern
PAT_INH_IV_VS_MAX
- 4 - when all cylinders are shut - off, the fuel pump is switched off.

These measures are cancelled following a definite process if the vehicle speed decreases under the vehicle speed limitation minus an hysteresis.

In order to avoid engine stall when the driver releases the clutch with cylinders shut - off due to vehicle speed limitation, the injection is enabled below the engine speed **3000 rpm**.

The application recurrence is **1 sec**.

Application conditions:

Activation:

If VS ≥ VS_MAX
and N_32 > 3000 rpm
then LV_VS_MAX = 1 (Active).

Deactivation:

If VS < VS_MAX - C_VS_MAX_HYS
or N_32 ≤ 3000 rpm
then LV_VS_MAX = 0 (Passive).

Editor: Müller O.	17-Dec-97	Auxiliary functions	HMC_V6
Version: a 153589 from 18.12.97		657765.49.08	
File: CHAP_9.DOC	650H0000	Sourcefile:07900C01.00D	Page 69 / 120

Proprietary data, company confidential. All rights reserved. Contine a titre de secret d'entreprise. Tous droits réservés. Comunicado como segredo empresarial. Reservados todos os direitos. Confidado como secreto industrial. Nos reservamos todos los derechos.

Weitergabe sowie Vervielfältigung dieser Unterlage, Verwertung und Mitteilung ihres Inhalts nicht gestattet, soweit nicht ausdrücklich zugestanden. Zuwiderhandlungen verpflichten zu Schadensersatz. Alle Rechte vorbehalten, insbesondere für den Fall der Patenterteilung oder GM-Enttragung

Formula section:

* **LV_VS_MAX = 1** (Active) - Vehicle speed limitation activation :

- 1 - All the enrichments are cancelled.
- 2 - A/F regulation loop is opened (LV_LSCL_1 = LV_LSCL_2 = 0) and mixture is leaned using (1 - C_TI_VS_MAX_COR).
- 3 - The cylinder shut - off level is set to 1 and increased by 1 every C_VS_MAX_CYCNR cycles.
- 4 - When all the cylinders are shut-off, the fuel pump is switched off.

* **LV_VS_MAX = 0** (Passive) - Vehicle speed limitation deactivation :

- 1 - The fuel pump is switched on (if it has been switched off before).
- 2 - The cylinder shut - off level is decreased by 1 every C_VS_MAX_CYCNR cycles.
- 3 - Once all the injectors are switched on again, all enrichments are enabled.
- 4 - A/F regulation loop is closed after C_LAM_CYCNR seconds.

Remark :

If $N_{32} \leq 3000$ rpm.
then the fuel pump is switched on (if it has been switched off before), all the cylinders are switched on, all enrichments are enabled and A/F regulation loop is closed after C_LAM_CYCNR seconds. These actions are performed together.

Calibration data:

Name	Dim	Hex. limits	Phys. limits	Resol.	Unit
C_VS_MAX_HYS	1	0...FFH	0...255	1	km/h
Hysteresis on maximum vehicle speed.					
C_VS_MAX_CYCNR	1	0...FFH	0...255	1	sec.
Time delay between two cylinders shut-off or reset during vehicle speed limitation (x 1 sec).					
C_LAM_CYCNR	1	01...FFFFH	0,01...655,35	0,01	sec.
Time delay before closing the A/F regulation loop.					

Editor: Müller O.	17-Dec-97	Auxiliary functions	HMC_V6
Version: a 153589 from 18.12.97		657765.49.08	
File: CHAP_9.DOC	650H0000	Sourcefile:07900C01.00D	Page 70 / 120

8 Traction Control

8.1 Interface Description

Output data:

Name	Mode	Hex. limits	Phys. limits	Resol.	Unit
TQI_ASR_REQ	V	0...3FH	0...630	10	Nm
Torque reduction requested for ASR from TCS control unit					
TQI_GS_REQ	V	0...3FH	0...630	10	Nm
Torque reduction requested for gear shift from TCU					
LV_ASR_REQ	V	0...1H	0..1	1	-
Boolean for ASR intervention requested by the TCS control unit					
LV_GS_REQ	V	0...1H	0..1	1	-
Boolean for GS intervention requested by the transmission control unit					
TQ_STND_CAN	-	0...3FH	0...630	10	Nm
standard torque to which all torque reduction requests are related (CAN-value)					
TQI_CAN	V	0...FFH	0...99.61	0.391	%
indicated engine torque without torque intervention (CAN-value)					
TQI_ACOR_CAN	V	0...FFH	0...99.61	0.391	%
indicated engine torque during torque intervention (CAN-value)					
TQFR_CAN	V	0...FFH	0...99.61	0.391	%
engine friction torque (CAN_value)					
ACK_TCS_CAN	-	0...1H	0..1	1	
acknowledge bit from EMS (CAN-value)					
TQ_COR_STAT_CAN	-	0...3H	0..3	1	
status of torque intervention from EMS (CAN-value)					

Input data:

TQI_TCS_CAN	TQI_TCU_CAN	TCS_REQ_CAN	SWI_GS_CAN
TQ_STND	TQI	TQI_INTV	TQFR
LV_ACK_TCS	STATE_TQ_INTV		

8.1.1 General information

The communication between the engine management system and the TCS control unit as well as the transmission control unit is done via the CAN bus.

This function description refers only to the torque management related CAN data. For a detailed description of the CAN functions please refer to the separate CAN specification.

To clearly distinguish between variables which are used for EMS internal calculation and variables that are available on the CAN all CAN-related variables are marked with the extension „_CAN“ at their name. However, in this chapter only the EMS internal variable names are used.

Editor: Müller O.	17-Dec-97	Auxiliary functions	HMC_V6
Version: a 153589 from 18.12.97		657765.49.08	
File: CHAP_9.DOC	650H0000	Sourcefile:07901301.00B	Page 71 / 120

8.1.2 CAN Communication Signals

8.1.2.1 EMS Input Signals from the CAN

Proprietary data, company confidential. All rights reserved.
 Contit a titre de secret d'entreprise. Tous droits réservés.
 Comunicado como segredo empresarial. Reservados todos os direitos.
 Confidado como secreto industrial. Nos reservamos todos los derechos.

Weitergabe sowie Vervielfältigung dieser Unterlage, Verwertung und Mitteilung ihres Inhalts nicht gestattet, soweit nicht ausdrücklich zugestanden. Zuwiderhandlungen verpflichten zu Schadensersatz. Alle Rechte vorbehalten, insbesondere für den Fall der Patenterteilung oder GM-Enttragung.

Input as CAN data (from the CAN)		Input to EMS internal functions
TQI_TCS_CAN [%]	Torque reduction request for ASR from TCS control unit	TQI_ASR_REQ [Nm]
	TQI_ASR_REQ = Fehler!	
TQI_TCU_CAN [%]	Torque reduction request for Gear-Shift from TCU	TQI_GS_REQ [Nm]
	TQI_GS_REQ = Fehler!	
TCS_REQ_CAN	Status-Bit = High, if ASR is requested	LV_ASR_REQ
SWI_GS_CAN	Status-Bit = High, if GS is requested	LV_GS_REQ

Editor: Müller O.	17-Dec-97	Auxiliary functions	HMC_V6
Version: a 153589 from 18.12.97		657765.49.08	
File: CHAP_9.DOC	650H0000	Sourcefile:07901301.00B	Page 72 / 120

8.1.2.2 EMS Output Signals to the CAN

Proprietary data, company confidential. All rights reserved.
 Contit a titre de secret d'entreprise. Tous droits réservés.
 Comunicado como segredo empresarial. Reservados todos os direitos.
 Confidado como secreto industrial. Nos reservamos todos los derechos.

Weitergabe sowie Vervielfältigung dieser Unterlage, Verwertung und Mitteilung ihres Inhalts nicht gestattet, soweit nicht ausdrücklich zugestanden. Zuwiderhandlungen verpflichten zu Schadensersatz. Alle Rechte vorbehalten, insbesondere für den Fall der Patenterteilung oder GM-Entragung.

Output from EMS internal functions

Output to CAN

TQ_STND
[Nm]

Standard engine torque in Nm, to which the percentage torque quantities TQx_yyy are related.
--> see subchapter Torque Model

TQ_STND_CAN
[Nm]

TQI
[Nm]

Indicated engine torque corresponding to the torque requested from the driver; including knock control, catalyst overheating protection and other ignition angle corrections; torque interventions are not included.
--> see subchapter Torque Model

TQI_CAN
[%]

TQI_CAN = **Fehler!*** 100%

TQI_INTV
[Nm]

Indicated engine torque during torque intervention.
--> see subchapter Torque Model

TQI_ACOR_CAN
[%]

TQI_ACOR_CAN = **Fehler!*** 100%

TQFR
[Nm]

Engine friction torque
--> see subchapter Torque Model

TQFR_CAN
[%]

TQFR_CAN = **Fehler!*** 100%

LV_ACK_TCS

Monitoring of the messages from the TCS control unit. The engine management system checks whether at least one new message from the TCS control unit has been transmitted within 500 ms. If so, the bit is set; else the bit is reset.

ACK_TCS_CAN

STATE_TQ_INTV

Status of torque intervention.
Check-back signal from the engine management system about to which extent a torque reduction is actually performed.

TQ_COR_STAT_CAN

Editor: Müller O.	17-Dec-97	Auxiliary functions	HMC_V6
Version: a 153589 from 18.12.97		657765.49.08	
File: CHAP_9.DOC	650H0000	Sourcefile:07901301.00B	Page 73 / 120

8.1.3 Status of Torque Intervention (STATE_TQ_INTV)

Output data:

Name	Mode	Hex. limits	Phys. limits	Resol.	Unit
STATE_TQ_INTV	V	0...3H	0...3	1	
status torque intervention from EMS					
TQ_INTV_REL_ERR	V	0...FFH	0...0.996	0.0039	100%
relative error as difference between actual torque and requested torque related to the standard torque					

Input data:

LV_ASR_REQ	LV_GS_REQ	TQI_INTV	TQI_ASR_REQ
TQI_GS_REQ	TQ_STND	LV_SCC_MOD	

FUNCTION DESCRIPTION:

General information:

The engine management system uses the variable **STATE_TQ_INTV** to inform the transmission control unit and/or the traction system control unit about the state of the torque intervention. That means if and to which extent an ignition angle intervention and/or a cylinder shut-off intervention are admitted.

Status	Bit 5	Bit 4	Meaning
0	0	0	The desired intervention regarding ignition angle retardation and cylinder shut-off is executed. (Default value)
1	0	1	The desired intervention regarding ignition angle retardation and cylinder shut-off is executed; however, the requested target torque can not be adjusted precisely (torque steps)
2	1	0	The torque reduction regarding the ignition angle retardation cannot be completely executed. A cylinder shut-off is not possible at this time. Therefore the residual torque (as difference between TQI_ASR_REQ and TQI_INTV) remains present and cannot be reduced.
3	1	1	Due to a failure detected by a diagnosis function of the engine management system, the desired torque intervention regarding the ignition angle and cylinder shut-off is no longer executed. The torque intervention is terminated, the engine management system resets the requested engine torque to the TQI value using a ramp.

Activation: LV_ASR_REQ = 1 or LV_GS_REQ = 1

Deactivation: LV_ASR_REQ = 0 and LV_GS_REQ = 0

Proprietary data, company confidential. All rights reserved. Contine a titre de secret d'entreprise. Tous droits réservés. Comunicado como segredo empresarial. Reservados todos os direitos. Confidado como secreto industrial. Nos reservamos todos los derechos.

Weitergabe sowie Vervielfältigung dieser Unterlage, Verwertung und Mitteilung ihres Inhalts nicht gestattet, soweit nicht ausdrücklich zugestanden. Zuwiderhandlungen verpflichten zu Schadenersatz. Alle Rechte vorbehalten, insbesondere für den Fall der Patenterteilung oder GM-Entragung.

Editor: Müller O.	17-Dec-97	Auxiliary functions	HMC_V6
Version: a 153589 from 18.12.97		657765.49.08	
File: CHAP_9.DOC	650H0000	Sourcefile:07901301.00B	Page 74 / 120

Formula section:

Relative Error of torque reduction intervention

$$TQ_INTV_REL_ERR = \text{Fehler!}$$

Status of torque intervention:

- Status 0: **If** $|TQ_INTV_REL_ERR| \leq C_TQ_INTV_REL_ERR_MAX$
 then **STATE_TQ_INTV = 0**
- Status 1: **If** $|TQ_INTV_REL_ERR| > C_TQ_INTV_REL_ERR_MAX$
 and $LV_SCC_MOD = 1$
 then **STATE_TQ_INTV = 1**
- Status 2: **If** $|TQ_INTV_REL_ERR| > C_TQ_INTV_REL_ERR_MAX$
 and $LV_SCC_MOD = 0$
 then **STATE_TQ_INTV = 2**
- Status 3: **If** no torque intervention is possible
 (for example due to a failure detected by a diagnosis function)
 then **STATE_TQ_INTV = 3**
 and **TQ_INTV_REL_ERR** is set to 100%

Calibration data:

Name	Dim	Hex. limits	Phys. limits	Resol.	Unit
C_TQ_INTV_REL_ERR_MAX	1	0...FFH	0...0.997	0.0039	100%
threshold for relative error of torque intervention for status output					

Editor: Müller O.	17-Dec-97	Auxiliary functions	HMC_V6
Version: a 153589 from 18.12.97		657765.49.08	
File: CHAP_9.DOC	650H0000	Sourcefile:07901301.00B	Page 75 / 120

8.2 Internal auxiliary quantities

8.2.1 Relative torque reduction by misfire detection (TQR_REL_SCC_MIS)

Output data:

Name	Mode	Hex. limits	Phys. limits	Resol.	Unit
TQR_REL_SCC_MIS	V	0...FFH	0...0.996	0.0039	100%
actual performed relative torque reduction by cylinder shut-off due to detected misfire					

Input data:

MIS_NR_OFF_IV			
---------------	--	--	--

FUNCTION DESCRIPTION:

The injection for misfiring cylinders is inhibited by the misfire detection function in order to prevent the catalyst from overheating. These fuel cut-off cylinders have to be considered for the calculation of the indicated engine torque without torque intervention (TQI) and the indicated engine torque during torque intervention (TQI_INTV).

TQR_REL_SCC_MIS = Fehler!

Calibration data:

non adjustable value: NC_CYL_NO = 6

Proprietary data, company confidential. All rights reserved. Contine a titre de secret d'entreprise. Tous droits réservés. Comunicado como segredo empresarial. Reservados todos os direitos. Confidado como secreto industrial. Nos reservamos todos los derechos.

Weitergabe sowie Vervielfältigung dieser Unterlage, Verwertung und Mitteilung ihres Inhalts nicht gestattet, soweit nicht ausdrücklich zugestanden. Zuwiderhandlungen verpflichten zu Schadenersatz. Alle Rechte vorbehalten, insbesondere für den Fall der Patenterteilung oder GM-Entragung.

Editor: Müller O.	17-Dec-97	Auxiliary functions	HMC_V6
Version: a 153589 from 18.12.97		657765.49.08	
File: CHAP_9.DOC	650H0000	Sourcefile:07901301.00B	Page 76 / 120

8.2.2 Actual performed relative torque reduction by fuel cut-off (TQR_REL_SCC_AV)

Output data:

Name	Mode	Hex. limits	Phys. limits	Resol.	Unit
TQR_REL_SCC_AV	V	0...FFH	0...0.996	0.0039	100%
actual performed relative torque reduction by any fuel cut-off action					

Input data:

TQR_REL_SCC_MIS	TQR_REL_SCC_OUT		
-----------------	-----------------	--	--

FUNCTION DESCRIPTION:

TQR_REL_SCC_AV is the actual performed relative torque reduction which can result from any fuel cut-off intervention including...

- ...fuel cut-off activated by the misfire detection : **TQR_REL_SCC_MIS** and/or
- ...fuel cut-off by a cylinder shut-off pattern : **TQR_REL_SCC_OUT**
 (from engine speed or vehicle speed limitation, torque reduction by TCU or TCS)

Formula section:

$$TQR_REL_SCC_AV = TQR_REL_SCC_OUT + TQR_REL_SCC_MIS - (TQR_REL_SCC_OUT * TQR_REL_SCC_MIS)$$

Proprietary data, company confidential. All rights reserved. Contient a titre de secret d'entreprise. Tous droits réservés. Comunicado como segredo empresarial. Reservados todos os direitos. Confidado como secreto industrial. Nos reservamos todos los derechos.

Weitergabe sowie Vervielfältigung dieser Unterlage, Verwertung und Mitteilung ihres Inhalts nicht gestattet, soweit nicht ausdrücklich zugestanden. Zuwiderhandlungen verpflichten zu Schadensersatz. Alle Rechte vorbehalten, insbesondere für den Fall der Patenterteilung oder GM-Entragung.

Editor: Müller O.	17-Dec-97	Auxiliary functions	HMC_V6
Version: a 153589 from 18.12.97		657765.49.08	
File: CHAP_9.DOC	650H0000	Sourcefile:07901301.00B	Page 77 / 120

8.2.3 Maximum relative torque reduction by spark retard (TQR_REL_MAX_IGA_N_MAF)

Output data:

Name	Mode	Hex. limits	Phys. limits	Resol.	Unit
TQR_REL_MAX_IGA_N_MAF	V	0...FFH	0...0.996	0.0039	100%
maximum possible relative torque reduction by spark retard					

Input data:

N_32	MAF	TQR_REL_SCC_AV	
------	-----	----------------	--

FUNCTION DESCRIPTION:

The maximum allowed ignition angle spark retard (regarding exhaust gas temperature) for torque intervention is taken from IP_IGA_DIF_MAX_TQR__N_32__MAF and results in a maximum relative torque reduction of IP_TQR_REL_MAX_IGA__N_32__MAF.

In order to take into account the torque decreasing influence of a currently performed cylinder shut-off, the factor (1 - TQR_REL_SCC_AV) is applied.

TQR_REL_MAX_IGA_N_MAF is calculated each 10 msecs.

Formula section:

$$TQR_REL_MAX_IGA_N_MAF = IP_TQR_REL_MAX_IGA_N_32_MAF * (1 - TQR_REL_SCC_AV)$$

Calibration data:

Name	Dim	Hex. limits	Phys. limits	Resol.	Unit
IP_TQR_REL_MAX_IGA__N_32__MAF	8x8	0...FFH	0...0.996	0.0039	100%
maximum possible relative torque reduction by spark retard					

Proprietary data, company confidential. All rights reserved. Contient a titre de secret d'entreprise. Tous droits réservés. Comunicado como segredo empresarial. Reservados todos os direitos. Confidado como secreto industrial. Nos reservamos todos los derechos.

Weitergabe sowie Vervielfältigung dieser Unterlage, Verwertung und Mitteilung ihres Inhalts nicht gestattet, soweit nicht ausdrücklich zugestanden. Zuwiderhandlungen verpflichten zu Schadensersatz. Alle Rechte vorbehalten, insbesondere für den Fall der Patenterteilung oder GM-Entragung.

8.2.4 Actual relative torque reduction by spark retard (TQR_REL_IGA_AV)

Output data:

Name	Mode	Hex. limits	Phys. limits	Resol.	Unit
IGA_DIF_REF_AV	V	0...FFH	0...-95.625	0.375	° CRK
applied relative ignition angle retardation to calculate the resulting torque reduction (difference between the reference IGA and the average of the actual IGAs of all cylinders)					
TQR_REL_IGA_AV	V	0...FFH	0...0.996	0.0039	100%
resulting actual value of the relative torque reduction by spark retard					
FAC_IGA_TQR	-	0...FFH	0...-95.625	0.375	° CRK
relative actual retardation related to the maximum possible spark retard					

Input data:

IGA_IGC_CYL_[CYL]	IGA_REF_TQR	N_32	MAF
TQR_REL_MAX_IGA_N_M AF	NC_CYL_NO	LV_ES	IP_FAC_TQR__FAC_IGA_TQR

FUNCTION DESCRIPTION:

General information:

TQR_REL_IGA_AV includes every spark retard intervention referring to the reference ignition angle IGA_REF_TQR.

Signal flow diagram:

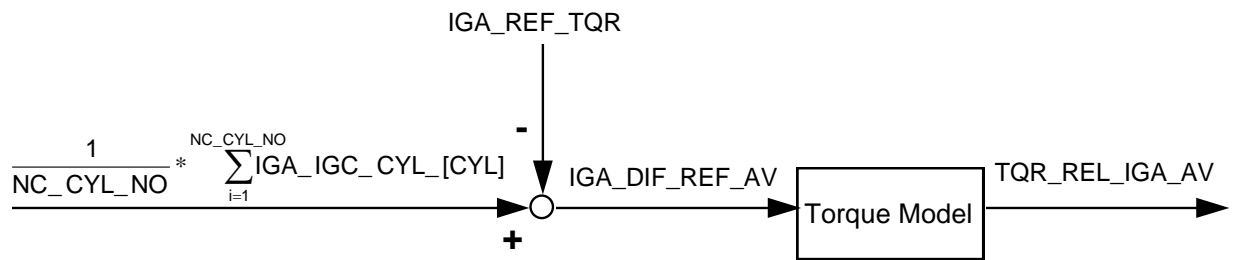

Activation: LV_ES = 0

Deactivation: LV_ES = 1

Editor: Müller O.	17-Dec-97	Auxiliary functions	HMC_V6
Version: a 153589 from 18.12.97		657765.49.08	
File: CHAP_9.DOC	650H0000	Sourcefile:07901301.00B	Page 79 / 120

Proprietary data, company confidential. All rights reserved. Contine a titre de secret d'entreprise. Tous droits réservés. Comunicado como segredo empresarial. Reservados todos os direitos. Confidado como secreto industrial. Nos reservamos todos los derechos.

Weitergabe sowie Vervielfältigung dieser Unterlage, Verwertung und Mitteilung ihres Inhalts nicht gestattet, soweit nicht ausdrücklich zugestanden. Zuwiderhandlungen verpflichten zu Schadensersatz. Alle Rechte vorbehalten, insbesondere für den Fall der Patenterteilung oder GM-Enttragung.

Formula section:

$$IGA_DIF_REF_AV = \left[\frac{1}{NC_CYL_NO} * \sum_{i=1}^{NC_CYL_NO} IGA_IGC_CYL_ [CYL] \right] - IGA_REF_TQR$$

(limited to ≤ 0 °CRK)

$$FAC_IGA_TQR = \frac{IGA_DIF_REF_AV}{IP_IGA_DIF_MAX_TQR_ _N_32_ _MAF}$$

$$TQR_REL_IGA_AV = IP_FAC_TQR_ _FAC_IGA_TQR * TQR_REL_MAX_IGA_N_MAF$$

Calibration data:

Name	Dim	Hex. limits	Phys. limits	Resol.	Unit
IP_IGA_DIF_MAX_TQR_ _N_32_ _MAF	8x8	0...FFH	0...-95.625	0.375	°CRK
maximum allowed spark retard for torque reduction					
IP_FAC_TQR_ _FAC_IGA_TQR	8	0...FFH	0...0.996	0.0039	100%
relative standard inverse ignition cog					

Proprietary data, company confidential. All rights reserved.
 Contit a titre de secret d'entreprise. Tous droits réservés.
 Comunicado como segredo empresarial. Reservados todos os direitos.
 Confidado como secreto industrial. Nos reservamos todos los derechos.

Weitergabe sowie Vervielfältigung dieser Unterlage, Verwertung und Mitteilung ihres Inhalts nicht gestattet, soweit nicht ausdrücklich zugestanden. Zuwiderhandlungen verpflichten zu Schadensersatz. Alle Rechte vorbehalten, insbesondere für den Fall der Patenterteilung oder GM-Enttragung

Editor: Müller O.	17-Dec-97	Auxiliary functions	HMC_V6
Version: a 153589 from 18.12.97		657765.49.08	
File: CHAP_9.DOC	650H0000	Sourcefile:07901301.00B	Page 80 / 120

8.3 Torque model

8.3.1 Standard torque (TQ_STND)

Output data:

Name	Mode	Hex. limits	Phys. limits	Resol.	Unit
TQ_STND	V	0...3FH	0...630	10	Nm
standard engine torque					

The standard engine torque **TQ_STND** is taken from C_TQ_STND and transmitted by the engine management system to the CAN stations (TCS control unit and TCU).

It is the reference torque to which the torque reduction quantities are related. The result are relative torque quantities as percentage which are put on the CAN.

Calibration data:

Name	Dim	Hex. limits	Phys. limits	Resol.	Unit
C_TQ_STND	1	0...3FH	0...630	10	Nm
standard engine torque					

8.3.2 Frictional torque (TQFR)

Output data:

Name	Mode	Hex. limits	Phys. limits	Resol.	Unit
TQFR	V	0...FFH	0...-255	1	Nm
engine friction torque					

Input data:

N_32	MAF	TCO	LV_RLY_ACCOUT
LV_PRS_ACC	LV_ES		

FUNCTION DESCRIPTION:

General information:

The frictional torque is a negative quantity. The following influences are considered in this model:

- N_32 engine speed
- MAF mass air flow
- TCO coolant temperature
- ACC air condition compressor on/off

Editor: Müller O.	17-Dec-97	Auxiliary functions	HMC_V6
Version: a 153589 from 18.12.97		657765.49.08	
File: CHAP_9.DOC	650H0000	Sourcefile:07901301.00B	Page 81 / 120

Application conditions:

Activation: LV_ES = 0

Deactivation: TQFR = 0 at engine operating state LV_ES = 1

Formula section:

If LV_RLY_ACCOUT = 0

then TQFR = IP_TQFR__N_32__MAF *(Influence of engine speed / load)*

+ IP_TQFR_ADD__TCO__TCO *(Influence of coolant temperature)*

If LV_RLY_ACCOUT = 1

and LV_PRS_ACC = 0

then TQFR = IP_TQFR__N_32__MAF *(Influence of engine speed / load)*

+ IP_TQFR_ADD__TCO__TCO *(Influence of coolant temperature)*

+ C_TQFR_ADD__ACC_L *(Influence of air condition compressor with low system pressure)*

If LV_RLY_ACCOUT = 1

and LV_PRS_ACC = 1

then TQFR = IP_TQFR__N_32__MAF *(Influence of engine speed / load)*

+ IP_TQFR_ADD__TCO__TCO *(Influence of coolant temperature)*

+ C_TQFR_ADD__ACC_H *(Influence of air condition compressor with high system pressure)*

Calibration data:

Name	Dim	Hex. limits	Phys. limits	Resol.	Unit
IP_TQFR__N_32__MAF	8x2	0...FFH	0...-255	1	Nm
basic engine friction torque					
IP_TQFR_ADD__TCO__TCO	8	0...FFH	+128...-127	1	Nm
coolant temperature correction for friction torque calculation					
C_TQFR_ADD__ACC_H	2	0...FFH	0...-255	1	Nm
Air condition compressor correction for friction torque calculation (High system pressure)					
C_TQFR_ADD__ACC_L	2	0...FFH	0...-255	1	Nm
Air condition compressor correction for friction torque calculation (Low system pressure)					

Editor:	Müller O.	17-Dec-97	Auxiliary functions	HMC_V6
Version:	a 153589 from 18.12.97		657765.49.08	
File:	CHAP_9.DOC	650H0000	Sourcefile:07901301.00B	Page 82 / 120

Proprietary data, company confidential. All rights reserved.
 Contití a titre de secret d'entreprise. Tous droits réservés.
 Comunicado como secreto empresarial. Reservados todos os direitos.
 Confidado como secreto industrial. Nos reservamos todos los derechos.

Weitergabe sowie Vervielfältigung dieser Unterlage, Verwertung und Mitteilung ihres Inhalts nicht gestattet, soweit nicht ausdrücklich zugestanden. Zuwiderhandlungen verpflichten zu Schadensersatz. Alle Rechte vorbehalten, insbesondere für den Fall der Patenterteilung oder GM-Entragung.

8.3.3 Indicated engine torque (TQI)

Output data:

Name	Mode	Hex. limits	Phys. limits	Resol.	Unit
TQI	V	0...FFH	0...510	2	Nm
indicated engine torque					

Input data:

N_32	MAF	TQR_REL_SCC_EMS	TQR_REL_IGA_EMS
IP_FAC_LAM_TQI_LAM_S UB_IGA_DIF_REF_AV	LV_ES	LV_PUC	IGA_DIF_REF_AV
LAM_SUB			

FUNCTION DESCRIPTION:

General information:

The indicated engine torque **TQI** refers to the drivers wish and is calculated from the mass air flow and engine speed. Additionally a lambda correction factor and a factor coming from spark retard and fuel cut-off is applied.

For the TQI calculation only spark retard interventions from EMS internal functions (e.g. knock correction, catalyst heating, anti jerk, etc.) or fuel cut-off due to engine speed limitation, vehicle speed limitation or misfire detection is considered.

However, the TQI calculation is independent from torque influence from ASR or gear shift.

The table **IP_FAC_LAM_TQI_LAM_SUB_IGA_DIF_REF_AV** is used to correct the indicated torque as a function of **LAM_SUB** and **IGA_DIF_REF_AV**.

Application conditions:

Activation: LV_ES = 0, LV_PUC = 0

Deactivation: TQI = 0 at engine operating states PUC and ES

Formula section:

$$\begin{aligned}
 \text{TQI} &= \text{IP_TQI_N_32_MAF} && \text{(Influence of engine speed / load)} \\
 & * \text{IP_FAC_LAM_TQI_LAM_SUB_IGA_DIF_REF_AV} && \text{(Influence of Lambda)} \\
 & * [1 - (\text{TQR_REL_IGA_EMS} && \text{(Influence of spark retard by EMS)} \\
 & \quad + \text{TQR_REL_SCC_EMS})] && \text{(Influence of cylinder shut-off effected by EMS)} \\
 & && \text{(N_MAX, VS_MAX, PUC and misfire)}
 \end{aligned}$$

Calibration data:

Name	Dim	Hex. limits	Phys. limits	Resol.	Unit
IP_TQI_N_32_MAF	8x2	0...FFH	0...510	2	Nm
Basis indicated engine torque					
IP_FAC_LAM_TQI_LAM_SUB_IGA_DIF_R EF_AV	6x6	0...FFH	0...1.992	0.0078	-
Lambda correction for indicated engine torque					
<i>Remark: In the application system this map is named IP_FAC_LAM_TQI_LAM_SUB_IGA_DIF</i>					

Editor: Müller O.	17-Dec-97	Auxiliary functions	HMC_V6
Version: a 153589 from 18.12.97		657765.49.08	
File: CHAP_9.DOC	650H0000	Sourcefile:07901301.00B	Page 83 / 120

Proprietary data, company confidential. All rights reserved.
 Contient a titre de secret d'entreprise. Tous droits réservés.
 Comunicado como segredo empresarial. Reservados todos os direitos.
 Confidado como secreto industrial. Nos reservamos todos los derechos.

Weitergabe sowie Vervielfältigung dieser Unterlage, Verwertung und Mitteilung ihres Inhalts nicht gestattet, soweit nicht ausdrücklich zugestanden. Zuwiderhandlungen verpflichten zu Schadenersatz. Alle Rechte vorbehalten, insbesondere für den Fall der Patenterteilung oder GM-Entragung.

8.3.3.1 Lambda influence weighted by ignition angle

Output data:

Name	Mode	Hex. limits	Phys. limits	Resol.	Unit
LAM_SUB	V	00...FFH	0...1.992	7.782E-3	-
Lambda substitute value					

Input data:

TIB	TI_MV		LV_ES
TI_AD_FAC_MMV	TI_AD_ADD_MMV		

FUNCTION DESCRIPTION:

With increasing retardation of the ignition angle the lambda dependence of the indicated engine torque TQI is enhanced.

Activation: LV_ES = 0

Deactivation: LV_ES = 1

Formula section:

$$LAM_SUB = \frac{TI_AD_FAC_MMV * TIB + TI_AD_ADD_MMV}{TI_MV}$$

Remark: TIB and TI_MV are without dead time.

Proprietary data, company confidential. All rights reserved. Contient a titre de secret d'entreprise. Tous droits réservés. Comunicado como segredo empresarial. Reservados todos os direitos. Confidado como secreto industrial. Nos reservamos todos los derechos.

Weitergabe sowie Vervielfältigung dieser Unterlage, Verwertung und Mitteilung ihres Inhalts nicht gestattet, soweit nicht ausdrücklich zugestanden. Zuwiderhandlungen verpflichten zu Schadensersatz. Alle Rechte vorbehalten, insbesondere für den Fall der Patenterteilung oder GM-Enttragung

Editor: Müller O.	17-Dec-97	Auxiliary functions	HMC_V6
Version: a 153589 from 18.12.97		657765.49.08	
File: CHAP_9.DOC	650H0000	Sourcefile:07901301.00B	Page 84 / 120

8.3.3.2 Influence of ignition angle

Input data:

FAC_IGA_TQR	FAC_TQR	
-------------	---------	--

Description:

The influence of the ignition angle on the indicated engine torque TQI is modeled via a general (relative) ignition cog. There are two tables for the relation between an ignition angle retard adjustment (compared to the absolute reference ignition angle IGA_REF_TQR) and the related relative reduction of the engine torque:

- **IP_FAC_TQR__FAC_IGA_TQR** to calculate the relative torque reduction for a differential ignition angle adjustment (relation IGA --> TQR)
- **IP_FAC_IGA_TQR__FAC_TQR** to calculate the ignition angle adjustment for a torque reduction request (relation TQI --> IGA)

For the calculation of TQI all ignition angle adjustments, such as knock control, catalyst heating, etc., are considered. ASR and GS are not included in the calculation of TQI.

Calibration data:

Name	Dim	Hex. limits	Phys. limits	Resol.	Unit
IP_FAC_IGA_TQR__FAC_TQR	8	0...FFH	0...0.996	0.0039	100%
relative standard ignition cog					
IP_FAC_TQR__FAC_IGA_TQR	8	0...FFH	0...0.996	0.0039	100%
relative standard inverse ignition cog					

8.3.3.2.1 Reference ignition angle (IGA_REF_TQR)

Output data:

Name	Mode	Hex. limits	Phys. limits	Resol.	Unit
IGA_REF_TQR	V	0...FFH	-23...72.5	0.375	°CRK
Reference ignition angle for torque intervention					

Input data:

IGA_BAS	IGA_EGR	
---------	---------	--

FUNCTION DESCRIPTION:

The reference ignition angle **IGA_REF_TQR** for this model approach is an absolute ignition angle, which is approximately identical to the ignition angle existing at maximum torque.

Formula section:

IGA_REF_TQR = IGA_BAS Basic ignition angle without EGR
 or
 IGA_EGR Basic ignition angle with EGR active

Editor: Müller O.	17-Dec-97	Auxiliary functions	HMC_V6
Version: a 153589 from 18.12.97		657765.49.08	
File: CHAP_9.DOC	650H0000	Sourcefile:07901301.00B	Page 85 / 120

Proprietary data, company confidential. All rights reserved. Contient des informations confidentielles de la société Siemens. Toute réimpression ou utilisation non autorisée sans la permission écrite de la société Siemens est formellement interdite. Reservados todos los derechos. No se permite la explotación económica ni la transformación de esta obra. Queda permitida la impresión en su totalidad. Reservados todos los derechos. No se permite la explotación económica ni la transformación de esta obra.

Weitergabe sowie Vervielfältigung dieser Unterlage, Verwertung und Mitteilung ihres Inhalts ist nicht gestattet, soweit nicht ausdrücklich zugestanden. Zuwiderhandlungen verpflichten zu Schadensersatz. Alle Rechte vorbehalten, insbesondere für den Fall der Patenterteilung oder GM-Enttragung.

8.3.3.2.2 Relative Torque Reduction by EMS internal Spark Retard (TQR_REL_IGA_EMS)

Output data:

Name	Mode	Hex. limits	Phys. limits	Resol.	Unit
IGA_DIF_REF_EMS	V	0...FFH	0...-95.625	0.375	° CRK
difference between actual ignition angle and torque reference ignition angle					
FAC_IGA_TQR	-	0...FFH	0...-95.625	0.375	° CRK
relative EMS internal ignition angle retardation related to the maximum possible spark retard					
TQR_REL_IGA_EMS	V	0...FFH	0...0.996	0.0039	100%
Relative torque reduction by EMS internal spark retard					

Input data:

IGA_CYL_[CYL]	IGA_REF_TQR	LV_ES	NC_CYL_NO
IP_IGA_DIF_MAX_TQR__N_32__MAF	TQR_REL_MAX_IGA_N_MAF	IP_FAC_TQR__FAC_IGA_TQR	

FUNCTION DESCRIPTION:

TQR_REL_IGA_EMS represents the EMS internal relative torque reduction by ignition angle retard adjustment (e.g. catalyst heating, knock control, transient spark retard, anti jerk function, etc.) related to the reference ignition angle IGA_REF_TQR.

IGA_DIF_REF_EMS is the current differential ignition angle relative to IGA_REF_TQR without ASR and GS intervention.

Application conditions:

Activation: not ES (LV_ES = 0)

Deactivation: ES (LV_ES = 0)

Formula section:

$$IGA_DIF_REF_EMS = \left[\frac{1}{NC_CYL_NO} * \sum_{i=1}^{NC_CYL_NO} IGA_CYL_ [CYL] \right] - IGA_REF_TQR$$

(limited to ≤ 0 °CRK)

$$FAC_IGA_TQR = \frac{IGA_DIF_REF_EMS}{IP_IGA_DIF_MAX_TQR_N_32_MAF}$$

$$TQR_REL_IGA_EMS = IP_FAC_TQR_FAC_IGA_TQR * TQR_REL_MAX_IGA_N_MAF$$

Proprietary data, company confidential. All rights reserved. Contine a titre de secret d'entreprise. Tous droits réservés. Comunicado como segredo empresarial. Reservados todos os direitos. Confidado como secreto industrial. Nos reservamos todos los derechos.

Weitergabe sowie Vervielfältigung dieser Unterlage, Verwertung und Mitteilung ihres Inhalts nicht gestattet, soweit nicht ausdrücklich zugestanden. Zuwiderhandlungen verpflichten zu Schadensersatz. Alle Rechte vorbehalten, insbesondere für den Fall der Patenterteilung oder GM-Entragung.

Editor: Müller O.	17-Dec-97	Auxiliary functions	HMC_V6
Version: a 153589 from 18.12.97		657765.49.08	
File: CHAP_9.DOC	650H0000	Sourcefile:07901301.00B	Page 86 / 120

8.3.3.3 Relative Torque Reduction by EMS internal Fuel Cut-Off (TQR_REL_SCC_EMS)

Output data:

Name	Mode	Hex. limits	Phys. limits	Resol.	Unit
PAT_INH_IV_MAX_N_VS	V	0...DH	0...13	1	-
maximum choice of pattern index between engine speed and vehicle speed limitation					
TQR_REL_SCC_EMS	V	0...FFH	0...0.996	0.0039	100%
relative torque reduction by EMS internal fuel cut-off functions					
TQR_REL_SCC_N_VS	V	0...FFH	0...0.996	0.0039	100%
maximum relative torque reduction by engine speed and vehicle speed limitation fuel cut-off functions					

Input data:

ID_TQR_REL_SCC__PAT _INH_IV	PAT_INH_IV_N_MAX	PAT_INH_IV_VS_MAX	TQR_REL_SCC_MIS
--------------------------------	------------------	-------------------	-----------------

FUNCTION DESCRIPTION:

General information:

Cylinder shut-offs by N_MAX and VS_MAX limitations are based on the same cylinder shut-off patterns as the TCS function. The effect of these cylinder shut-offs on the engine torque is included in the calculation by the internal quantity **TQR_REL_SCC_EMS**.

If a cylinder shut-off is requested by several functions at the same time, this results in a maximum selection of the pattern index requests **PAT_INH_IV_MAX_N_VS** and the resulting relative torque reduction **TQR_REL_SCC_N_VS**.

If the misfire detection inhibits a certain cylinder, it will remain inhibited until switched back on by the misfire detection. A cylinder which is shut-off due to misfire is ignored by the TCS shut-off pattern. This shut-off cylinder influences the TQI and is considered in the engine torque model by the relative torque reduction **TQR_REL_SCC_MIS**.

Formula section:

$$PAT_INH_IV_MAX_N_VS = \max(PAT_INH_IV_N_MAX, PAT_INH_IV_VS_MAX)$$

$$TQR_REL_SCC_N_VS = ID_TQR_REL_SCC_PAT_INH_IV_MAX_N_VS$$

The total effect of the resulting relative torque reduction by EMS internal fuel shut-off functions and misfiring cylinder inhibition is given by following interference formula:

$$TQR_REL_SCC_EMS = TQR_REL_SCC_N_VS + TQR_REL_SCC_MIS - (TQR_REL_SCC_N_VS * TQR_REL_SCC_MIS)$$

This formula is only valid for rolling pattern and steady state fuel shut-off of one or more individual cylinder (like misfire cylinder inhibition).

Proprietary data, company confidential. All rights reserved. Contine a titre de secret d'entreprise. Tous droits réservés. Comunicado como segredo empresarial. Reservados todos os direitos. Confidado como secreto industrial. Nos reservamos todos los derechos.

Weitergabe sowie Vervielfältigung dieser Unterlage, Verwertung und Mitteilung ihres Inhalts nicht gestattet, soweit nicht ausdrücklich zugestanden. Zuwiderhandlungen verpflichten zu Schadenersatz. Alle Rechte vorbehalten, insbesondere für den Fall der Patenterteilung oder GM-Entragung.

Editor: Müller O.	17-Dec-97	Auxiliary functions	HMC_V6
Version: a 153589 from 18.12.97		657765.49.08	
File: CHAP_9.DOC	650H0000	Sourcefile:07901301.00B	Page 87 / 120

8.4 Exhaust gas temperature model

Output data:

Name	Mode	Hex. limits	Phys. limits	Resol.	Unit
TEG_STAT	V	0...7FF0H	0...2047	0.0625	°C
steady state exhaust gas temperature					
TEG_MMV_SUB	V	0...7FF0H	0...2047	0.0625	°C
dynamic exhaust gas temperature					
POW_DIF	V	0...FD03H	0...69.08	1.067E-03	kW
Power representing the increase of the exhaust gas temperature due to spark retardation					
CRLC_TEG	-	0...FFFFH	0...0.999985	1.525E-05	-
Correlation constant for exhaust gas temperature calculation					

Input data:

N	N_32	MAF	MAF_KGH
VS	PAT_INH_IV	LAM_SUB	TCO
TQR_REL_IGA_AV	LV_ES	TQI	

FUNCTION DESCRIPTION:

General information:

The exhaust gas temperature model calculates a theoretical exhaust gas temperature **TEG_MMV_SUB** upstream of the catalytic converter. This temperature serves as a decision criterion for the torque reduction logic module to apportion the desired torque reduction into an IGA- and a SCC-component.

The following input variables are used by the first order model approach to calculate the **TEG_MMV_SUB** in intervals of 1 second:

- N_32 engine speed
- MAF, MAF_KGH mass air flow
- VS vehicle speed
- POW_DIF differential power representing the exhaust gas temperature increase by spark retardation
- PAT_INH_IV fuel shut-off pattern index
- LAM_SUB lambda substitute value

The calculated temperature **TEG_MMV_SUB** is initialized at engine start, using the actual measured coolant temperature TCO.

Application conditions:

Activation: not ES (LV_ES = 0)

Deactivation: ES (LV_ES = 0)

Editor: Müller O.	17-Dec-97	Auxiliary functions	HMC_V6
Version: a 153589 from 18.12.97		657765.49.08	
File: CHAP_9.DOC	650H0000	Sourcefile:07901301.00B	Page 88 / 120

Proprietary data, company confidential. All rights reserved. Contine a titre de secret d'entreprise. Tous droits réservés. Comunicado como segredo empresarial. Reservados todos os direitos. Confidado como secreto industrial. Nos reservamos todos los derechos.

Weitergabe sowie Vervielfältigung dieser Unterlage, Verwertung und Mitteilung ihres Inhalts nicht gestattet, soweit nicht ausdrücklich zugestanden. Zuwiderhandlungen verpflichten zu Schadensersatz. Alle Rechte vorbehalten, insbesondere für den Fall der Patenterteilung oder GM-Enttragung.

8.4.1 Stationary exhaust gas temperature (TEG_STAT)

Formula section:

TEG_STAT =

$$\begin{aligned}
 & [1 - ID_TEG_FAC_SCC_PAT_INH_IV] && \text{influence of cylinder shut-off} \\
 & * [&& \\
 & \quad (IP_TEG_N_32_MAF && \text{basic stationary exhaust gas temperature} \\
 & \quad + IP_TEG_ADD_IGA_POW_DIF && \text{Temperature rise due to} \\
 & \quad) && \text{retarded ignition angle} \\
 & \quad * IP_TEG_FAC_LAM_LAM_SUB && \text{Lambda dependence of exhaust gas} \\
 & && \text{temperature} \\
 & \quad * IP_TEG_FAC_VS_VS && \text{influence of cooling air as a function of} \\
 &] && \text{driving speed} \\
 & + ID_TEG_FAC_SCC_PAT_INH_IV && \text{influence of cylinder shut-off} \\
 & * (TCO + IP_TEG_STAT_ADD_SCC_MAF_KGH) && \text{correction for stationary exhaust gas} \\
 & && \text{temperature at fuel shut-off}
 \end{aligned}$$

Temperature increase by spark retard:

This model approach relates the temperature increase to the retarded ignition angle. It is assumed that this decrease of the engine power is directly turned into heat.

The connection between the rise of the exhaust gas temperature and the applied relative spark retard is given by the differential power POW_DIF, which represents the amount of reduced torque that is turned into heat. It is calculated using the actual relative torque reduction by spark retard TQR_REL_IGA_AV, the engine speed N and the indicated engine torque TQI.

Formula section:

$$POW_DIF = TQI * N * TQR_REL_IGA_AV$$

Proprietary data, company confidential. All rights reserved. Contine a titre de secret d'entreprise. Tous droits réservés. Comunicado como segredo empresarial. Reservados todos os direitos. Confidado como secreto industrial. Nos reservamos todos los derechos.

Weitergabe sowie Vervielfältigung dieser Unterlage, Verwertung und Mitteilung ihres Inhalts nicht gestattet, soweit nicht ausdrücklich zugestanden. Zuwiderhandlungen verpflichten zu Schadenersatz. Alle Rechte vorbehalten, insbesondere für den Fall der Patenterteilung oder GM-Entragung.

Editor:	Müller O.	17-Dec-97	Auxiliary functions	HMC_V6
Version:	a 153589 from 18.12.97		657765.49.08	
File:	CHAP_9.DOC	650H0000	Sourcefile:07901301.00B	Page 89 / 120

8.4.2 Dynamic Exhaust Gas Temperature (TEG_MMV_SUB)

Filter constants:

If TEG_STAT > TEG_MMV_SUB then **CRLC_TEG = ID_CRLC_TEG_INC__MAF_KGH**

If TEG_STAT ≤ TEG_MMV_SUB then **CRLC_TEG = ID_CRLC_TEG_DEC__MAF_KGH**

Exhaust gas model temperature:

$$TEG_MMV_SUB_n = TEG_MMV_SUB_{n-1} + CRLC_TEG * (TEG_STAT - TEG_MMV_SUB_{n-1})$$

Calibration data:

Name	Dim	Hex. limits	Phys. limits	Resol.	Unit
IP_TEG__N_32__MAF	8x8	0...7FF0H	0...2047	0.0625	°C
basic table of the exhaust gas temperature					
ID_TEG_FAC_SCC__PAT_INH_IV	14	0...FFH	0...1.992	0.0078	-
influence of fuel cut-off on the exhaust gas temperature					
IP_TEG_FAC_LAM__LAM_SUB	6	0...FFH	0...1.992	0.0078	-
influence of lambda on the exhaust gas temperature					
IP_FAC_VS_TEG__VS	6	0...FFH	0...1.992	0.0078	-
influence of the vehicle speed on the exhaust gas temperature					
IP_TEG_ADD_IGA__POW_DIF	4	0...7FF0H	0...2047	1	°C
temperature rise due to retarded ignition angle					
ID_CRLC_TEG_INC__MAF_KGH	6	0...FFFFH	0...1.000	1.53E-5	-
correlation constant for exhaust gas temperature increase					
ID_CRLC_TEG_DEC__MAF_KGH	6	0...FFFFH	0...1.000	1.53E-5	-
correlation constant for exhaust gas temperature decrease					
IP_TEG_STAT_ADD_SCC__MAF_KGH	6	0...FFH	-100...300	1.569	°C
temperature rise due to cylinder shut-off					

Proprietary data, company confidential. All rights reserved. Contient des informations confidentielles. Tous droits réservés.

Weitergabe sowie Vervielfältigung dieser Unterlage, Verbreitung und Mitteilung ihres Inhalts nicht gestattet, soweit nicht ausdrücklich zugestanden. Zuwiderhandlungen verpflichten zu Schadenersatz. Alle Rechte vorbehalten, insbesondere für den Fall der Patenterteilung oder GM-Entragung.

Editor: Müller O.	17-Dec-97	Auxiliary functions	HMC_V6
Version: a 153589 from 18.12.97		657765.49.08	
File: CHAP_9.DOC	650H0000	Sourcefile:07901301.00B	Page 90 / 120

8.5 Torque Intervention for ASR and Gear Shift

Output data:

Name	Mode	Hex. limits	Phys. limits	Resol.	Unit
TQR_REL_IGA_OUT	V	0...FFH	0...0.996	0.0039	100%
Relative output torque reduction by spark retard					
TQR_REL_SCC_OUT	V	00...FFH	0...0.997	0.0039	100%
Relative output torque reduction by fuel cut-off					
LV_CDN_ASR	-	0...1H	0...1	1	-
logical value for possible ASR intervention					
LV_CDN_GS	V	0...1H	0...1	1	-
logical value for possible gear shift					
TQR_REL_OUT	V	0...FFH	0...0.996	0.0039	100%
General output of torque reduction					
T_GS_DLY_DIAG	V	0...FFFFH	0...655.35	0.01	s
Diagnosis time during gear-shift					

Input data:

LV_IV_[CYL]_ERR	LV_MAF_ERR	LV_CPS_ERR	N
N_SP_IS	TQI_TCS_CAN	TQ_STND	TQI
TQR_AS	LV_ASR_REQ	LV_ES	LV_ST
LV_IS	LV_DRI	TQI_TCU_CAN	TQR_REL_IGA_OUT

FUNCTION DESCRIPTION:

General information:

The torque intervention logic of the engine management system determines the valid target torque TQI_ASR_REQ or TQI_GS_REQ, which can be requested by the traction control system or the transmission control unit.

This target torque can be reached by ignition angle adjustment and/or cylinder shut-off.

The indicated engine torque is linearly decreased by cylinder shut-off, depending on the number of shut-off cylinders respectively the index of the shut-off pattern. The transitions are performed by a steady ignition angle adjustment.

Editor: Müller O.	17-Dec-97	Auxiliary functions	HMC_V6
Version: a 153589 from 18.12.97		657765.49.08	
File: CHAP_9.DOC	650H0000	Sourcefile:07901301.00B	Page 91 / 120

Proprietary data, company confidential. All rights reserved. Contine a titre de secret d'entreprise. Tous droits réservés. Comunicado como segredo empresarial. Reservados todos os direitos. Confidado como secreto industrial. Nos reservamos todos los derechos.

Weitergabe sowie Vervielfältigung dieser Unterlage, Verwertung und Mitteilung ihres Inhalts nicht gestattet, soweit nicht ausdrücklich zugestanden. Zuwiderhandlungen verpflichten zu Schadensersatz. Alle Rechte vorbehalten, insbesondere für den Fall der Patenterteilung oder GM-Entragung.

Proprietary data, company confidential. All rights reserved.
 Contine a titre de secret d'entreprise. Tous droits réservés.
 Comunicado como segredo empresarial. Reservados todos os direitos.
 Confidado como secreto industrial. Nos reservamos todos los derechos.

Weitergabe sowie Vervielfältigung dieser Unterlage, Verwertung und Mitteilung ihres Inhalts nicht gestattet, soweit nicht ausdrücklich zugestanden. Zuwiderhandlungen verpflichten zu Schadensersatz. Alle Rechte vorbehalten, insbesondere für den Fall der Patenterteilung oder GM-Entragung.

The torque intervention logic module decides about the applied apportionment of IGA and SCC components to reach the requested target torque (TQI_ASR_REQ or TQI_GS_REQ) based on the following conditions:

- Engine operating point (N, MAF)
- Operating states (WUP, catalyst protection)
- Exhaust gas temperature (TEMP_MMV_SUB)
- Engine speed and TCO limits (VS, TCO)

The torque resulting from the torque model as actual target torque for the intervention (TQI_INTV) is put on the CAN by the engine management system. The torque intervention logic adjusts to a reduced torque which is the closest to the requested torque.

Under limit conditions (for example when a high exhaust gas temperature is present or when the catalyst overheating protection is active or due to the minimum cylinder shut-off pattern ID_NR_PAT_MIN_LAM_SUB_TEG_DIF) it is possible that the requested torque can not be adjusted.

Output variables are the torque intervention to be executed via ignition angle adjustment **TQR_REL_IGA_OUT** and via cylinder shut-off **TQR_REL_SCC_OUT**.

Three operating modes are available for a torque reduction intervention:

- IGA ignition angle adjustment exclusively
- SCC/IGA cylinder shut-off in combination with ignition angle adjustment
- SCC cylinder shut-off exclusively

The ignition angle adjustment mode allows a quick torque reaction resulting in a good driveability. However, it can cause an increase of the exhaust gas temperature and is therefore only admissible up to a certain exhaust gas temperature.

The combination mode of cylinder shut-off and ignition angle adjustment is less critical regarding the exhaust gas temperature and permits extended torque interventions, but with the disadvantage of a worse driveability.

If a maximum exhaust gas temperature is exceeded during the combined intervention, the ignition angle intervention is no longer accepted, but only the cylinder shut-off will be effective.

Editor: Müller O.	17-Dec-97	Auxiliary functions	HMC_V6
Version: a 153589 from 18.12.97		657765.49.08	
File: CHAP_9.DOC	650H0000	Sourcefile:07901301.00B	Page 92 / 120

8.5.1 Overview of the possible torque interventions

Proprietary data, company confidential. All rights reserved. Contine a titre de secret d'entreprise. Tous droits réservés. Comunicado como segredo empresarial. Reservados todos os direitos. Confidado como secreto industrial. Nos reservamos todos los derechos.

Weitergabe sowie Vervielfältigung dieser Unterlage, Wertung und Mitteilung ihres Inhalts nicht gestattet, soweit nicht ausdrücklich zugestanden. Zuwiderhandlungen verpflichten zu Schadensersatz. Alle Rechte vorbehalten, insbesondere für den Fall der Patenterteilung oder GM-Entragung.

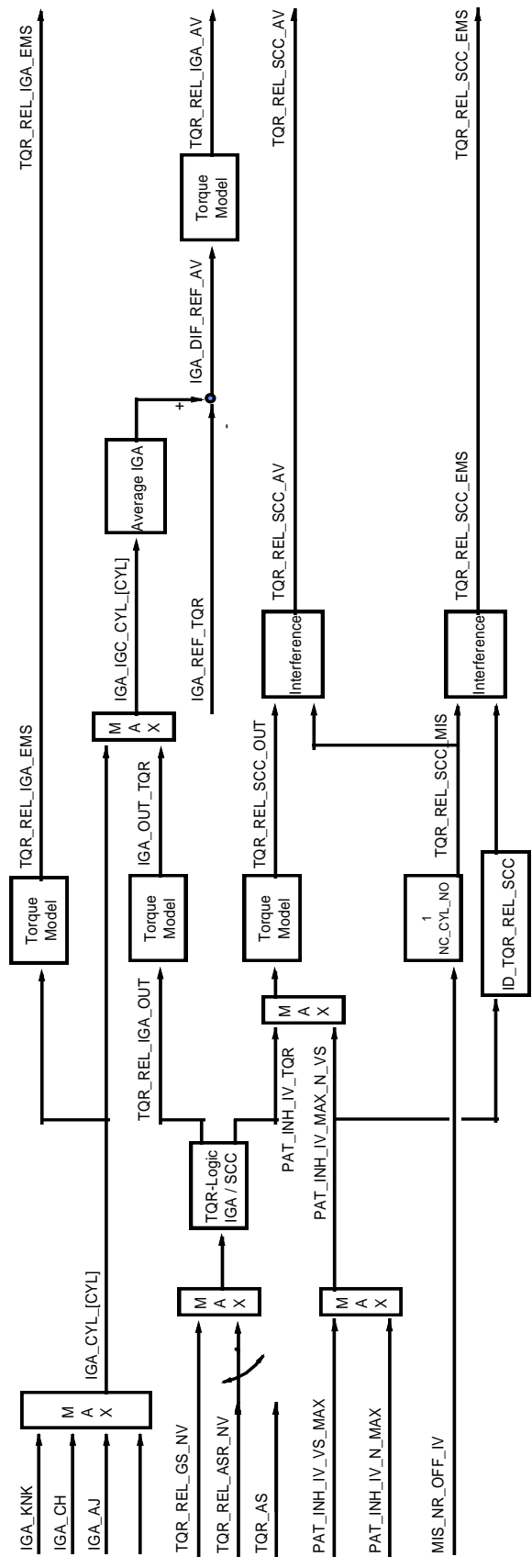

Editor: Müller O.	17-Dec-97	Auxiliary functions	HMC_V6
Version: a 153589 from 18.12.97		657765.49.08	
File: CHAP_9.DOC	650H0000	Sourcefile:07901301.00B	Page 93 / 120

8.5.2 Conditions for ASR- and GS-intervention

Conditions for a ASR intervention:

```

If          LV_IV_[CYL]_ERR = 0           (no error at the injectors)
and         LV_MAF_ERR = 0                (no error at the mass air flow sensor)
and         LV_CPS_ERR = 0                (no error at the canister purge solenoid)
and         N > N_SP_IS + C_N_ADD_ASR     (engine speed threshold)
and         [   TQI_TCS_CAN < 100% (TQ_STND) (ASR-req. torque below TQ_STND)
                and TQI_ASR_REQ < TQI     (ASR-requested torque below TQI)
                and LV_ASR_REQ = 1       (ASR intervention requested by control unit)
                ] or TQR_AS > 0          (torque intervention by application system)
then        LV_CDN_ASR = 1                (ASR intervention possible)
else        LV_CDN_ASR = 0                (ASR intervention not possible)
    
```

Conditions for a Gear-Shift intervention:

```

If          LV_ES = 0
and         LV_ST = 0
and         LV_IS = 0
and         LV_DRI = 1                    (With A/T: Drive selected)
and         TQI_TCU_CAN < 100% (TQ_STND) (GS-requested torque below TQ_STND)
and         TQI_GS_REQ < TQI             (GS-requested torque below TQI)
and         TQI_GS_REQ < TQI_ASR_REQ     (req. torque for GS below ASR-request)
and         T_GS_DLY_DIAG < C_T_GS_DLY_DIAG (GS duration below limit)
then        LV_CDN_GS = 1                (Gear shift intervention possible)
else        LV_CDN_GS = 0                (Gear shift intervention not possible)
    
```

Calibration data:

Name	Dim	Hex. limits	Phys. limits	Resol.	Unit
C_N_ADD_ASR	1	0...FFH	0...8160	32	rpm
engine speed offset to nominal speed value for activation of ASR					
C_T_GS_DLY_DIAG	1	0...FFFFH	0...655.35	0.01	s
Diagnosis timer threshold for gear shift					

Editor: Müller O.	17-Dec-97	Auxiliary functions	HMC_V6
Version: a 153589 from 18.12.97		657765.49.08	
File: CHAP_9.DOC	650H0000	Sourcefile:07901301.00B	Page 94 / 120

Proprietary data, company confidential. All rights reserved. Contine a titre de secret d'entreprise. Tous droits réservés. Comunicado como segredo empresarial. Reservados todos os direitos. Confidado como secreto industrial. Nos reservamos todos los derechos.

Weitergabe sowie Vervielfältigung dieser Unterlage, Wertung und Mitteilung ihres Inhalts nicht gestattet, soweit nicht ausdrücklich zugestanden. Zuwiderhandlungen verpflichten zu Schadensersatz. Alle Rechte vorbehalten, insbesondere für den Fall der Patenterteilung oder GM-Entragung.

8.5.3 Torque Reduction Intervention

8.5.3.1 Relative Nominal Torque Reduction for ASR (TQR_REL_ASR_NV)

Output data:

Name	Mode	Hex. limits	Phys. limits	Resol.	Unit
TQR_REL_ASR_NV	V	0..FFH	0...0.996	0.0039	100%
Nominal torque reduction for ASR					

Input data:

LV_CDN_ASR	TQI_ASR_REQ	IP_TQI__N_32__MAF	IP_FAC_LAM_TQI__LAM_S UB__IGA_DIF_REF_AV
------------	-------------	-------------------	---

Application conditions:

If LV_CDN_ASR = 1
then TQR_REL_ASR_NV =

else TQR_REL_ASR_NV = 0

1 - Fehler!

Proprietary data, company confidential. All rights reserved.
 Contient a titre de secret d'entreprise. Tous droits réservés.
 Comunicado como segredo empresarial. Reservados todos os direitos.
 Confidado como secreto industrial. Nos reservamos todos los derechos.

Weitergabe sowie Vervielfältigung dieser Unterlage, Verwertung und Mitteilung ihres Inhalts nicht gestattet, soweit nicht ausdrücklich zugestanden. Zuwiderhandlungen verpflichten zu Schadensersatz. Alle Rechte vorbehalten, insbesondere für den Fall der Patenterteilung oder GM-Eintragung.

Editor: Müller O.	17-Dec-97	Auxiliary functions	HMC_V6
Version: a 153589 from 18.12.97		657765.49.08	
File: CHAP_9.DOC	650H0000	Sourcefile:07901301.00B	Page 95 / 120

8.5.3.2 Relative Nominal Torque Reduction for GS (TQR_REL_GS_NV)

Output data:

Name	Mode	Hex. limits	Phys. limits	Resol.	Unit
TQR_REL_GS_NV	V	0...FFH	0...0.997	0.0039	100%
Torque Reduction for Gear Shift					

Input data:

LV_CDN_GS	TQI_GS_REQ	IP_TQI__N_32__MAF	IP_FAC_LAM_TQI__LAM_S UB_IGA_DIF_REF_AV
-----------	------------	-------------------	--

Application conditions:

If LV_CDN_GS = 1
then TQR_REL_GS_NV =

1 - Fehler!

else TQR_REL_GS_NV = 0

8.5.3.3 Determination of the Torque Reduction Amount

Output data:

Name	Mode	Hex. limits	Phys. limits	Resol.	Unit
TQR_REL_NV	V	0...FFH	0...0.997	0.0039	100%
Torque reduction input for torque model based on ASR- and GS-request					

Input data:

TQR_REL_GS_NV	TQR_REL_ASR_NV		
---------------	----------------	--	--

General information:

A torque intervention for gear shift and ASR can happen at the same time. The intervention is done according to the lowest requested torque.

Formula Section:

TQR_REL_NV = MAX (TQR_REL_GS_NV, TQR_REL_ASR_NV)

Editor: Müller O.	17-Dec-97	Auxiliary functions	HMC_V6
Version: a 153589 from 18.12.97		657765.49.08	
File: CHAP_9.DOC	650H0000	Sourcefile:07901301.00B	Page 96 / 120

Proprietary data, company confidential. All rights reserved. Contient a titre de secret d'entreprise. Tous droits réservés. Comunicado como segredo empresarial. Reservados todos os direitos. Confidado como secreto industrial. Nos reservamos todos los derechos.

Weitergabe sowie Vervielfältigung dieser Unterlage, Verwertung und Mitteilung ihres Inhalts nicht gestattet, soweit nicht ausdrücklich zugestanden. Zuwiderhandlungen verpflichten zu Schadenersatz. Alle Rechte vorbehalten, insbesondere für den Fall der Patenterteilung oder GM-Entragung.

8.5.3.4 Selection of the Torque Reduction Mode

Output data:

Name	Mode	Hex. limits	Phys. limits	Resol.	Unit
LV_IGA_ADJ_MOD	V	0...1H	0...1	1	-
Boolean for ignition angle adjustment for torque reduction					
LV_SCC_MOD	V	0...1H	0...1	1	-
Boolean for fuel cut-off for torque reduction					
LV_TEG_MAX	V	0...1H	0...1	1	-
Boolean for maximum allowed exhaust gas temperature exceeded					

Input data:

TCO	TQR_REL_NV	TQR_REL_MAX_IGA_N_M AF	TEG_MMV_SUB
-----	------------	---------------------------	-------------

General Information:

A hysteresis is used for determination of the torque reduction mode.

```

If    TCO > C_TCO_MIN_SCC
then  if    [ TQR_REL_NV > TQR_REL_MAX_IGA_N_MAF
              or    N_32 > C_N_MAX_IGA_TQR ]
then  LV_SCC_MOD = 1
else  if    TEG_MMV_SUB > C_TEG_THD_2
then  LV_SCC_MOD = 1
else  if    TEG_MMV_SUB < C_TEG_THD_1
then  LV_SCC_MOD = 0
else  LV_SCC_MOD = 0

If    N_32 < C_N_MAX_IGA_TQR
then  if    [ LV_TEG_MAX = 0 and TEG_MMV_SUB < C_TEG_MAX ]
              or [ LV_TEG_MAX = 1 and TEG_MMV_SUB < C_TEG_THD_2 ]
then  LV_IGA_ADJ_MOD = 1
else  if    TEG_MMV_SUB > C_TEG_MAX
then  LV_IGA_ADJ_MOD = 0
              and  LV_TEG_MAX = 1
else  LV_IGA_ADJ_MOD = 0
              and  LV_TEG_MAX = 0
    
```

Editor: Müller O.	17-Dec-97	Auxiliary functions	HMC_V6
Version: a 153589 from 18.12.97		657765.49.08	
File: CHAP_9.DOC	650H0000	Sourcefile:07901301.00B	Page 97 / 120

Proprietary data, company confidential. All rights reserved.
 Contient des informations confidentielles. Tous droits réservés.
 Comunicado como secreto empresarial. Reservados todos los derechos.
 Confidado como secreto industrial. Nos reservamos todos los derechos.

Weitergabe sowie Vervielfältigung dieser Unterlage, Verwertung und Mitteilung ihres Inhalts ist gestattet, soweit nicht ausdrücklich zugestanden. Zuwiderhandlungen verpflichten zu Schadensersatz. Alle Rechte vorbehalten, insbesondere für den Fall der Patenterteilung oder GM-Eintragung.

Reset of LV_TEG_MAX:

```

If    TQR_REL_NV = 0
then  LV_TEG_MAX = 0
        and LV_SCC_MOD = 0
        and LV_IGA_ADJ_MOD = 0
    
```

8.5.3.5 Exhaust gas temperature logic

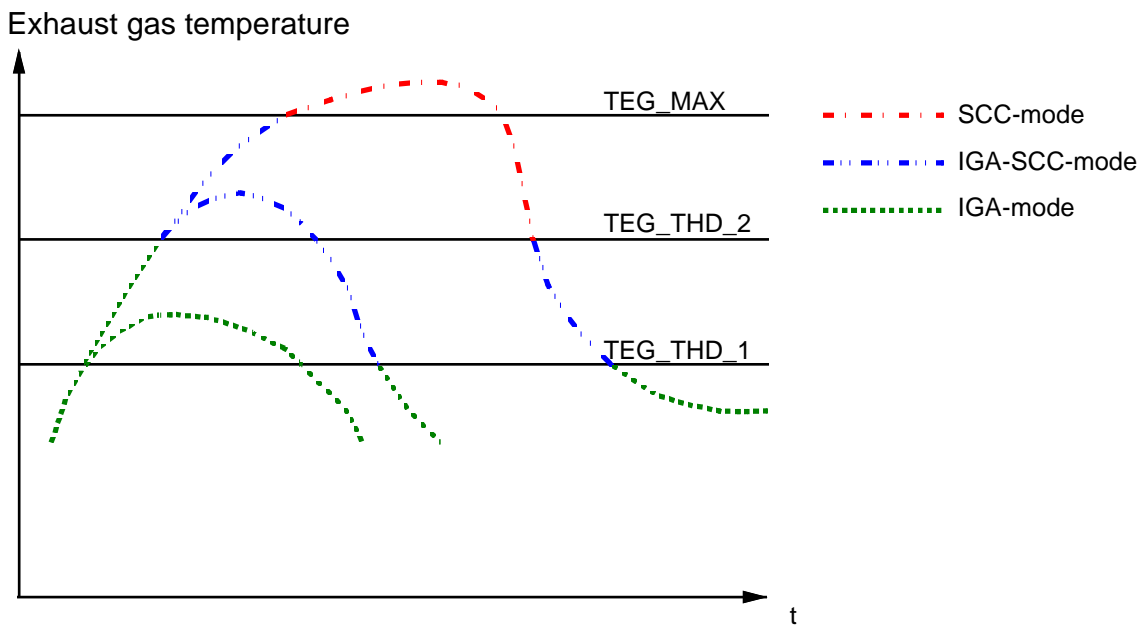

The above diagram represents possible exhaust gas temperatures **TEG_MMV_SUB** during an ASR intervention with the three operating modes available for torque reduction.

Calibration data:

Name	Dim	Hex. limits	Phys. limits	Resol.	Unit
C_TCO_MIN_SCC	1	0...FEH	-48...142.50	0.55	°C
exhaust gas temperature threshold 1					
C_TEG_THD_1	1	0...7FF0H	0...2047	0.0625	°C
exhaust gas temperature threshold 1					
C_TEG_THD_2	1	0...7FF0H	0...2047	0.0625	°C
exhaust gas temperature threshold 2					
C_TEG_MAX	1	0...7FF0H	0...2047	0.0625	°C
maximum allowable exhaust gas temperature					
C_N_MAX_IGA_TQR	1	0...FF0H	0...8160	32	rpm
maximum allowed engine speed for ignition angle intervention					

Editor: Müller O.	17-Dec-97	Auxiliary functions	HMC_V6
Version: a 153589 from 18.12.97		657765.49.08	
File: CHAP_9.DOC	650H0000	Sourcefile:07901301.00B	Page 98 / 120

8.5.3.6 Ignition Angle Adjustment (IGA_ADJ) Mode

Output data:

Name	Mode	Hex. limits	Phys. limits	Resol.	Unit
TQR_REL_IGA_OUT	V	0...FFH	0...0.997	0.0039	100%
relative torque reduction by ignition angle adjustment					
TQR_REL_SCC_OUT	V	0...FFH	0...0.996	0.0039	100%
relative torque reduction by fuel cut-off					
PAT_INH_IV_TQR	V	0...DH	0...13	1	-
index pattern for cylinder shut-off for torque reduction					
LV_IGA_ADJ_TQR	V	0...1H	0...1	1	-
Boolean for torque reduction by spark retard					
LV_SCC_TQR	V	0...1H	0...1	1	-
Boolean for torque reduction by fuel cut-off					

Input data:

LV_IGA_ADJ_MOD	LV_SCC_MOD	TQR_REL_NV	TQR_REL_MAX_IGA_N_MAF
----------------	------------	------------	-----------------------

FUNCTION DESCRIPTION:

General information:

In the ignition angle adjustment mode, the required torque reduction TQR_REL_NV is performed exclusively via spark retard. Torque interventions by ignition angle intervention are clearly preferred as they do not affect the driveability.

Vehicle take-off or slip occurring during cornering require a very quick torque intervention. In such cases, a new ASR request is executed exclusively by spark retard up to the possible extent (limitations by exhaust gas temperature or ignition angle).

- The following function is effected by the ignition angle adjustment:
 - Knock adaptation is inhibited

Application conditions:

Activation / Deactivation

If LV_IGA_ADJ_MOD = 1
and LV_SCC_MOD = 0
then TQR_REL_IGA_OUT = Min (TQR_REL_NV, TQR_REL_MAX_IGA_N_MAF)
and LV_IGA_ADJ_TQR = 1
and LV_SCC_TQR = 0
and TQR_REL_SCC_OUT = 0
and PAT_INH_IV_TQR = 0

Editor: Müller O.	17-Dec-97	Auxiliary functions	HMC_V6
Version: a 153589 from 18.12.97		657765.49.08	
File: CHAP_9.DOC	650H0000	Sourcefile:07901301.00B	Page 99 / 120

Proprietary data, company confidential. All rights reserved.
 Contine a titre de secret d'entreprise. Tous droits réservés.
 Comunicado como segredo empresarial. Reservados todos os direitos.
 Confidado como secreto industrial. Nos reservamos todos los derechos.

Weitergabe sowie Vervielfältigung dieser Unterlage, Verwertung und Mitteilung ihres Inhalts nicht gestattet, soweit nicht ausdrücklich zugestanden. Zuwiderhandlungen verpflichten zu Schadensersatz. Alle Rechte vorbehalten, insbesondere für den Fall der Patenterteilung oder GM-Entragung.

8.5.3.7 Cylinder Shut-Off (SCC) Mode

Output data:

Name	Mode	Hex. limits	Phys. limits	Resol.	Unit
TQR_REL_IGA_OUT	V	00...FFH	0...0.997	0.0039	100%
relative torque reduction by spark retard					
TQR_REL_SCC_OUT	V	0...FFH	0...0.996	0.0039	100%
relative torque reduction by fuel cut-off					
PAT_INH_IV_TQR	V	0...DH	0...13	1	-
index of fuel cut-off pattern for torque reduction					
LV_IGA_ADJ_TQR	V	0...1H	0...1	1	-
Boolean for torque reduction by spark retard					
LV_SCC_TQR	V	0...1H	0...1	1	-
Boolean for torque reduction by fuel cut-off					

Input data:

LV_SCC_MOD	LV_IGA_ADJ_MOD	ID_PAT_INH_IV_MIN__LA M_SUB__TEG_DIF	
------------	----------------	---	--

FUNCTION DESCRIPTION:

General information:

With this mode the torque reduction request TQR_REL_NV is answered exclusively by a cylinder shut-off.

With the used cylinder shut-off pattern the engine torque can be only adjusted in steps. However, as a shut-off pattern of 13 is used, the steps are very small and therefore the torque reduction performance and the driveability are not effected excessively.

- The following functions are effected by the cylinder shut-off:
 - Lambda control loop is opened
 - Catalyst overheating protection function
 - Warm-up enrichment is switched to separate ASR warm-up enrichment
 - Full load enrichment is inhibited
 - Cold post-start enrichment is inhibited
 - Knock adaptation is inhibited
 - CPS is closed
 - EGR valve is closed
 - Fuel leaning function during cylinder shut-off is enabled

Editor: Müller O.	17-Dec-97	Auxiliary functions	HMC_V6
Version: a 153589 from 18.12.97		657765.49.08	
File: CHAP_9.DOC	650H0000	Sourcefile:07901301.00B	Page 100 / 120

Proprietary data, company confidential. All rights reserved. Contine a titre de secret d'entreprise. Tous droits réservés. Comunicado como segredo empresarial. Reservados todos os direitos. Confidado como secreto industrial. Nos reservamos todos los derechos.

Weitergabe sowie Vervielfältigung dieser Unterlage, Verwertung und Mitteilung ihres Inhalts nicht gestattet, soweit nicht ausdrücklich zugestanden. Zuwiderhandlungen verpflichten zu Schadensersatz. Alle Rechte vorbehalten, insbesondere für den Fall der Patenterteilung oder GM-Enttragung

Proprietary data, company confidential. All rights reserved. Contine a titre de secret d'entreprise. Tous droits réservés. Comunicado como secreto empresarial. Reservados todos os direitos. Confidado como secreto industrial. Nos reservamos todos los derechos.

Weitergabe sowie Vervielfältigung dieser Unterlage, Verwertung und Mitteilung ihres Inhalts nicht gestattet, soweit nicht ausdrücklich zugestanden. Zuwiderhandlungen verpflichten zu Schadenersatz. Alle Rechte vorbehalten, insbesondere für den Fall der Patenterteilung oder GM-Entragung.

Application conditions:

Activation / Deactivation

```

If          LV_SCC_MOD = 1
    and      LV_IGA_ADJ_MOD = 0
then       PAT_INH_IV_TQR = Max (ID_PAT_INH_IV_MIN_LAM_SUB_TEG_DIF,
                                ID_PAT_INH_IV_TQR__TQR_REL_NV)
    If          PAT_INH_IV_TQR > 0
    then       LV_SCC_TQR = 1
                and TQR_REL_SCC_OUT = ID_TQR_REL_SCC__PAT_INH_IV_TQR
                and TQR_REL_IGA_OUT = 0
                and LV_IGA_ADJ_TQR = 0
    else       TQR_REL_SCC_OUT = 0
                and LV_SCC_TQR = 0
    
```

Calibration data:

Name	Dim	Hex. limits	Phys. limits	Resol.	Unit
ID_TQR_REL_SCC__PAT_INH_IV_TQR	14	0...FFH	0...0.996	0.0039	100%
relative torque reduction by fuel cut-off pattern					
<i>Remark: In the application system the name of this map is ID_TQR_REL_SCC__PAT_INH_IV</i>					
ID_PAT_INH_IV_TQR__TQR_REL_NV	6x6	0...DH	0...13	1	
Cylinder shut-off pattern number for torque reduction					

Editor: Müller O.	17-Dec-97	Auxiliary functions	HMC_V6
Version: a 153589 from 18.12.97		657765.49.08	
File: CHAP_9.DOC	650H0000	Sourcefile:07901301.00B	Page 101 / 120

8.5.3.8 Torque Reduction by Single Cylinder Shut-Off (SCC) and Ignition Angle Adjustment (IGA_ADJ) Mode

Output data:

Name	Mode	Hex. limits	Phys. limits	Resol.	Unit
TQR_REL_IGA_OUT	V	00...FFH	0...0.997	0.0039	100%
relative torque reduction by ignition angle adjustment					
TQR_REL_SCC_OUT	V	0...FFH	0...0.997	0.0039	100%
relative torque reduction by fuel cut-off					
TQR_REL_MAX_IGA_TEG	V	0...FFH	0...0.997	0.0039	100%
maximum relative torque reduction by ignition angle adjustment regarding exhaust gas temperature					
PAT_INH_IV_TQR	V	0...DH	0...13	1	-
index for fuel cut-off pattern for torque reduction					
LV_IGA_ADJ_TQR	V	0...1H	0...1	1	-
Boolean for torque reduction by spark retard					
LV_SCC_TQR	V	0...1H	0...1	1	-
Boolean for torque reduction by fuel cut-off					

Input data:

LV_SCC_MOD	LV_IGA_ADJ_MOD	ID_PAT_INH_IV_TQR__TQ R_REL_NV	TQR_REL_MAX_IGA_N_M AF
TEG_DIF	N	TQI	TQR_REL_NV

FUNCTION DESCRIPTION:

General information:

In case of this torque reduction mode the requested torque is executed by a combination of cylinder shut-off and ignition angle retard adjustment.

This mode is activated if the ignition angle adjustment mode can no longer be kept alone and if the following conditions are met.

Application conditions:

If LV_SCC_MOD = 1
and LV_IGA_ADJ_MOD = 1

then

a) Determination of the torque reduction portion by cylinder shut-off

$$PAT_INH_IV_TQR = \text{Max} (ID_PAT_INH_IV_MIN_LAM_SUB_TEG_DIF, ID_PAT_INH_IV_TQR_TQR_REL_NV)$$

If PAT_INH_IV_TQR > 0

then TQR_REL_SCC_OUT = ID_TQR_REL_SCC__PAT_INH_IV_TQR

and LV_SCC_TQR = 1

else TQR_REL_SCC_OUT = 0

Editor: Müller O.	17-Dec-97	Auxiliary functions	HMC_V6
Version: a 153589 from 18.12.97		657765.49.08	
File: CHAP_9.DOC	650H0000	Sourcefile:07901301.00B	Page 102 / 120

and LV_SCC_TQR = 0

Proprietary data, company confidential. All rights reserved.
Contitue a titre de secret d'entreprise. Tous droits réservés.
Comunicado como segredo empresarial. Reservados todos os direitos.
Confidado como secreto industrial. Nos reservamos todos los derechos.

Weitergabe sowie Vervielfältigung dieser Unterlage, Wertung und Mitteilung ihres Inhalts nicht gestattet, soweit nicht ausdrücklich zugestanden. Zuwiderhandlungen verpflichten zu Schadensersatz. Alle Rechte vorbehalten, insbesondere für den Fall der Patenterteilung oder GM-Eintragung

Editor: Müller O.	17-Dec-97	Auxiliary functions	HMC_V6
Version: a 153589 from 18.12.97		657765.49.08	
File: CHAP_9.DOC	650H0000	Sourcefile:07901301.00B	Page 103 / 120

b) Determination of the torque reduction portion by ignition angle adjustment

```

if      TQR_REL_NV - TQR_REL_SCC_OUT > 0
then    TQR_REL_MAX_IGA_TEG = Fehler!
          and TQR_REL_IGA_OUT = Min (TQR_REL_NV - TQR_REL_SCC_OUT,
                                     TQR_REL_MAX_IGA_N_MAF,
                                     TQR_REL_MAX_IGA_TEG)

          and LV_IGA_ADJ_TQR = 1
else    TQR_REL_IGA_OUT = 0
          and LV_IGA_ADJ_TQR = 0
    
```

When the requested torque reduction TQR_REL_NV increases (or either TQI_ASR_REQ or TQI_GS_REQ decreases), the retard adjustment of the ignition angle TQR_REL_IGA_OUT moves to a maximum value, which is given by ID_TQR_REL_SCC_PAT_INH_IV_TQR. The maximum ignition angle retard adjustment is limited by TQR_REL_MAX_IGA_N_MAF, or TQR_REL_MAX_IGA_TEG.

To avoid an excessive rise of the exhaust gas temperature, there is a minimum cylinder shut-off pattern ID_NR_PAT_MIN_LAM_SUB_TEG_DIF. A hysteresis function enables the return to the "zero pattern" using TQR_REL_SCC_OUT = 0. The cylinder shut-off is only canceled if the torque request condition TQR_REL_NV = 0 is present.

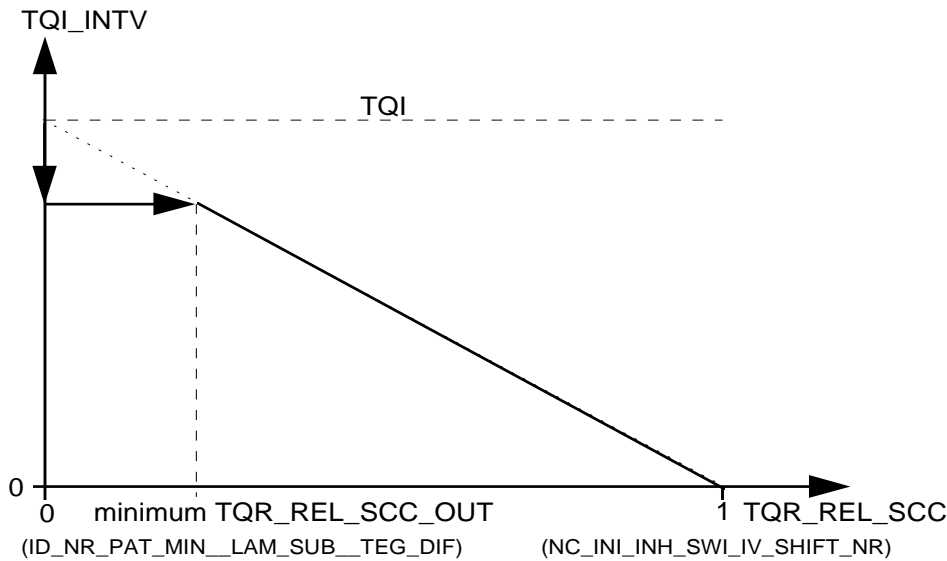

Calibration data:

Name	Dim	Hex. limits	Phys. limits	Resol.	Unit
C_TEG_FAC_IGA	1	0...FFFFH	0...0.1	1.53E-6	
factor temperature increase of spark retard					
ID_TQR_REL_SCC_PAT_INH_IV	14	0...FFH	0...0.996	0.0035	
relative torque reduction by fuel cut-off pattern					
ID_PAT_INH_IV_MIN_LAM_SUB_TEG_dif	6x6	0...DH	0...13	1	
Minimum pattern number for torque reduction					

Editor: Müller O.	17-Dec-97	Auxiliary functions	HMC_V6
Version: a 153589 from 18.12.97		657765.49.08	
File: CHAP_9.DOC	650H0000	Sourcefile:07901301.00B	Page 104 / 120

Proprietary data, company confidential. All rights reserved. Contine a titre de secret d'entreprise. Tous droits réservés. Comunicado como segredo empresarial. Reservados todos os direitos. Confidado como secreto industrial. Nos reservamos todos los derechos.

Weitergabe sowie Vervielfältigung dieser Unterlage, Verwertung und Mitteilung ihres Inhalts ist gestattet, soweit nicht ausdrücklich zugestanden. Zuwiderhandlungen verpflichten zu Schadensersatz. Alle Rechte vorbehalten, insbesondere für den Fall der Patenterteilung oder GM-Enttragung.

8.5.3.9 Minimum Torque Reduction Pattern

Output data:

Name	Mode	Hex. limits	Phys. limits	Resol.	Unit
TEG_DIF	V	0...FFF0H	-2048...2047	0.0625	°C
Difference between calculated and maximum allowed exhaust gas temperature					

Input data:

TEG_MMV_SUB	C_TEG_MAX		
-------------	-----------	--	--

FUNCTION DESCRIPTION:

In case of a cylinder shut-off, all stationary mixture enrichments have to be terminated. To prevent the exhaust gas temperature from increasing even more by a cylinder shut-off after an active catalyst overheating prevention enrichment, only activation of cylinder shut-off patterns $PAT_INH_IV_TQR \geq ID_PAT_INH_IV_MIN_LAM_SUB_TEG_DIF$ are admitted. This minimum allowed cylinder shut-off pattern is selected as a function of TEG_DIF and of the lambda substitute value LAM_SUB.

The differential temperature TEG_DIF is calculated at intervals of a second.

$$TEG_DIF = TEG_MMV_SUB - C_TEG_MAX$$

Proprietary data, company confidential. All rights reserved. Contine a titre de secret d'entreprise. Tous droits réservés. Comunicado como segredo empresarial. Reservados todos os direitos. Confidado como secreto industrial. Nos reservamos todos los derechos.

Weitergabe sowie Vervielfältigung dieser Unterlage, Verwertung und Mitteilung ihres Inhalts nicht gestattet, soweit nicht ausdrücklich zugestanden. Zuwiderhandlungen verpflichten zu Schadensersatz. Alle Rechte vorbehalten, insbesondere für den Fall der Patenterteilung oder GM-Entragung

Editor: Müller O.	17-Dec-97	Auxiliary functions	HMC_V6
Version: a 153589 from 18.12.97		657765.49.08	
File: CHAP_9.DOC	650H0000	Sourcefile:07901301.00B	Page 105 / 120

8.5.3.10 Hysteresis between Cylinder Shut-Off and Ignition Angle Adjustment

FUNCTION DESCRIPTION:

The switch point to a different shut-off pattern is expanded to a switch range using the hysteresis C_TQR_HYS. This way, a permanent switching between the IGA_ADJ and SCC modes is avoided, if the desired torque TQI_ASX_REQ fluctuates around a certain operating point.

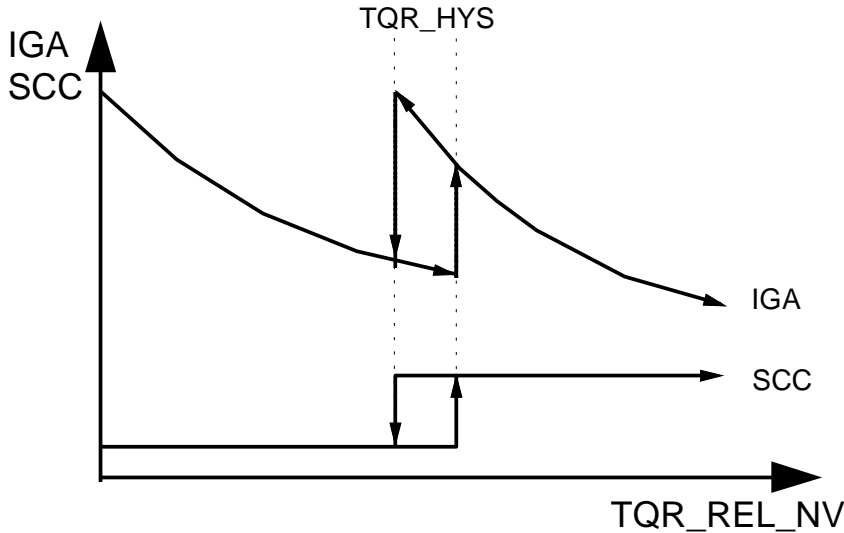

Hysteresis between cylinder shut-off (SCC) and ignition angle adjustment (IGA)

Calibration data:

Name	Dim	Hex. limits	Phys. limits	Resol.	Unit
C_TQR_HYS	1	00...FFH	0...0.997	3.895E-3	
Hysteresis between ignition angle adjustment and cylinder shut-off					

Proprietary data, company confidential. All rights reserved. Contine a titre de secret d'entreprise. Tous droits réservés. Comunicado como secreto empresarial. Reservados todos os direitos. Confidado como secreto industrial. Nos reservamos todos los derechos.

Weitergabe sowie Veröffentlichung dieser Unterlage, Verwertung und Mitteilung ihres Inhalts nicht gestattet, soweit nicht ausdrücklich zugestanden. Zuwiderhandlungen verpflichten zu Schadensersatz. Alle Rechte vorbehalten, insbesondere für den Fall der Patenterteilung oder GM-Eintragung.

Editor: Müller O.	17-Dec-97	Auxiliary functions	HMC_V6
Version: a 153589 from 18.12.97		657765.49.08	
File: CHAP_9.DOC	650H0000	Sourcefile:07901301.00B	Page 106 / 120

8.5.4 Torque Intervention by the Application System

Output data:

Name	Mode	Hex. limits	Phys. limits	Resol.	Unit
TQR_AS	V	00...FFH	0...0.997	0.0039	100%
torque reduction request by application tool					

Application conditions:

Activation:

The constant **C_TQR_AS** is implemented to assist in the application process.

If **C_TQR_AS > 0** then the requested torque is determined by the maximum selection of TQR_REL_ASR_NV, TQR_REL_GS_NV or TQR_AS.

Deactivation: C_TQR_AS = 0

Calibration data:

Name	Dim	Hex. limits	Phys. limits	Resol.	Unit
C_TQR_AS	1	00...FFH	0...0.997	3.895E-3	
application assistance relative torque reduction					

Proprietary data, company confidential. All rights reserved. Contient a titre de secret d'entreprise. Tous droits réservés. Comunicado como segredo empresarial. Reservados todos os direitos. Confidado como secreto industrial. Nos reservamos todos los derechos.

Weitergabe sowie Vervielfältigung dieser Unterlage, Wertung und Mitteilung ihres Inhalts nicht gestattet, soweit nicht ausdrücklich zugestanden. Zuwiderhandlungen verpflichten zu Schadensersatz. Alle Rechte vorbehalten, insbesondere für den Fall der Patenterteilung oder GM-Entragung.

Editor: Müller O.	17-Dec-97	Auxiliary functions	HMC_V6
Version: a 153589 from 18.12.97		657765.49.08	
File: CHAP_9.DOC	650H0000	Sourcefile:07901301.00B	Page 107 / 120

8.6 Execution of a Torque Intervention

8.6.1 Ignition Angle Retard Adjustment (IGA_ADJ_TQR)

Output data:

Name	Mode	Hex. limits	Phys. limits	Resol.	Unit
IGA_ADJ_TQR	V	0...FFH	0...-95.625	0.375	°CRK
ignition angle adjustment for torque intervention					
IGA_OUT_TQR_NV	V	0...FFH	72...-23.625	0.375	°CRK
applied ignition angle for torque intervention without gradient limitation					
IGA_OUT_TQR	V	0...FFH	72...-23.625	0.375	°CRK
applied ignition angle for torque intervention with gradient limitation					
FAC_TQR	V	0...FFH	0...0.997	0.0039	100%
relative torque reduction by ignition angle adjustment					

Input data:

TQR_REL_IGA_OUT	TQR_REL_MAX_IGA_N_M AF	IGA_REF_TQR	IP_FAC_IGA_TQR__FAC_ TQR
-----------------	---------------------------	-------------	-----------------------------

Signal flow diagram:

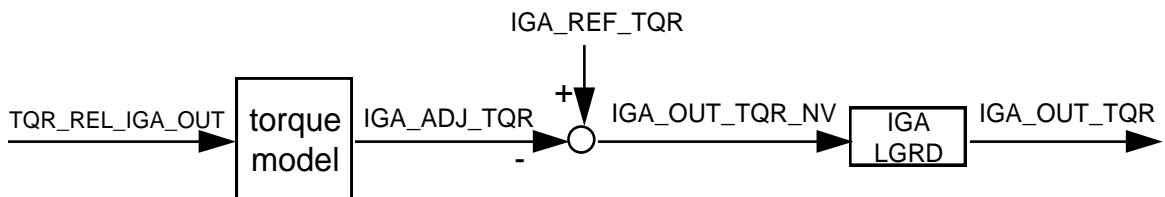

Formula section:

If TQR_REL_IGA_OUT > 0
then FAC_TQR = TQR_REL_IGA_OUT / TQR_REL_MAX_IGA_N_MAF
and IGA_ADJ_TQR =
 IP_FAC_IGA_TQR__FAC_TQR * IP_IGA_DIF_MAX_TQR__N_32__MAF
and IGA_OUT_TQR_NV = IGA_REF_TQR - IGA_ADJ_TQR
and IGA_OUT_TQR = IGA_OUT_TQR_NV - C_IGA_LGRD_TQR

Ignition angle retard adjustments are effected without limitation gradient, advance adjustments are effected with the gradient limitation C_IGA_LGRD_TQR.

Calibration data:

Name	Dim	Hex. limits	Phys. limits	Resol.	Unit
IP_IGA_DIF_MAX_TQR__N_32__MAF	8x8	0...FFH	0...-95.625	0.375	°CRK
maximum spark retard for torque reduction					
C_IGA_LGRD_TQR	1	0...FFH	0...95.625		°CRK/Seg
limitation gradient for ignition angle adjustment					

Editor: Müller O.	17-Dec-97	Auxiliary functions	HMC_V6
Version: a 153589 from 18.12.97		657765.49.08	
File: CHAP_9.DOC	650H0000	Sourcefile:07901301.00B	Page 108 / 120

Proprietary data, company confidential. All rights reserved. Contiene información confidencial. Todos los derechos reservados. Contiene a titre de secret d'entreprise. Tous droits réservés. Comunicado como secreto empresarial. Reservados todos os direitos. Comunicado como secreto industrial. Nos reservamos todos los derechos.

Weitergabe sowie Vervielfältigung dieser Unterlage, Verwertung und Mitteilung ihres Inhalts ist gestattet, soweit nicht ausdrücklich zugestanden. Zuwiderhandlungen verpflichten zu Schadensersatz. Alle Rechte vorbehalten, insbesondere für den Fall der Patenterteilung oder GM-Entragung.

8.6.2 Selection of Cylinder Shut-Off Patterns

Remark:

The selection of the applied cylinder shut-off pattern is described in the chapter „Injection“ in the subchapter „Cylinder Fuel Cut-Off“.

8.7 Auxiliary functions

8.7.1 ASR Warm-up

Output data:

Name	Mode	Hex. limits	Phys. limits	Resol.	Unit
TI_WUP_COR	V	0...7F0H	0...0.496	0.00244	
warm-up enrichment correction					

Input data:

TCO	TCO_ST	LV_SCC_TQR	
-----	--------	------------	--

General information:

In order to protect the catalyst from overheating by a secondary air effect at fuel cut-off mode (which can happen especially at cold engine temperatures) because of a high wall film in the intake manifold, a more lean warm-up-enrichment is necessary.

To ensure an uninterrupted engine operation (without misfires) in the warm-up phase, the warm-up enrichment cannot be foregone completely in the SCC mode.

Description:

With a cylinder shut-off active, there is a switch from the normal warm-up injection time IP_TI_TCO_WUP__TCO__TCO_ST to IP_TI_TCO_WUP_ASR__TCO__TCO_ST which is leaner than the normal one.

Application conditions:

Activation: LV_SCC_TQR = 1

Deactivation: LV_SCC_TQR = 0

Formula section:

$$\begin{aligned}
 TI &= TIB \\
 &: \\
 &*(1 + TI_WUP_COR) \\
 &:
 \end{aligned}$$

$$TI_WUP_COR = IP_TI_WUP_N_MAF * IP_TI_TCO_WUP_ASR_TCO_TCO_ST$$

Editor: Müller O.	17-Dec-97	Auxiliary functions	HMC_V6
Version: a 153589 from 18.12.97		657765.49.08	
File: CHAP_9.DOC	650H0000	Sourcefile:07901301.00B	Page 109 / 120

Proprietary data, company confidential. All rights reserved. Contine a titre de secret d'entreprise. Tous droits réservés. Comunicado como segredo empresarial. Reservados todos os direitos. Confidado como secreto industrial. Nos reservamos todos los derechos.

Weitergabe sowie Vervielfältigung dieser Unterlage, Verwertung und Mitteilung ihres Inhalts nicht gestattet, soweit nicht ausdrücklich zugestanden. Zuwiderhandlungen verpflichten zu Schadenersatz. Alle Rechte vorbehalten, insbesondere für den Fall der Patenterteilung oder GM-Enttragung

Proprietary data, company confidential. All rights reserved. Contient des informations confidentielles. Tous droits réservés. Contiene datos de la empresa. Reservados todos los derechos. Comunicado como secreto empresarial. Reservados todos los derechos. Confidado como secreto industrial. Nos reservamos todos los derechos.

Weitergabe sowie Vervielfältigung dieser Unterlage, Verwertung und Mitteilung ihres Inhalts ist gestattet, soweit nicht ausdrücklich zugestanden. Zuwiderhandlungen verpflichten zu Schadensersatz. Alle Rechte vorbehalten, insbesondere für den Fall der Patenterteilung oder GM-Enttragung.

Calibration data:

Name	Dim	Hex. limits	Phys. limits	Resol.	Unit
IP_TI_TCO_WUP_ASR_TCO_TCO_ST	8x3	0...FFH	0 ...1.992	0.0078	
TI warm up correction during ASR intervention					

8.7.2 Leaning Function for Cylinder Shut-Off outside the Warm-Up Mode

Input data:

MAF_KGH	LV_SCC_TQR	
---------	------------	--

General information:

To protect the catalytic converter against the secondary air effect (air + excess fuel) in the cylinder shut-off mode, **ID_TI_SCC_MAF_KGH** can be used to obtain an adjustable enleaning of the active cylinders via MAF_KGH.

Application conditions:

Activation: LV_SCC_TQR = 1

Deactivation: LV_SCC_TQR = 0

Formula section:

$$\begin{aligned}
 TI = & \quad TIB \\
 & \quad \cdot \\
 & \quad \cdot \\
 & \quad \cdot (1 - ID_TI_SCC_MAF_KGH) \\
 & \quad \cdot \\
 & \quad \cdot
 \end{aligned}$$

Calibration data:

Name	Dim	Hex. limits	Phys. limits	Resol.	Unit
ID_TI_SCC_MAF_KGH	6	0...FFH	0...0.5	0.00196	
fuel leaning during cylinder shut-off mode for torque intervention					

Editor: Müller O.	17-Dec-97	Auxiliary functions	HMC_V6
Version: a 153589 from 18.12.97		657765.49.08	
File: CHAP_9.DOC	650H0000	Sourcefile:07901301.00B	Page 110 / 120

8.7.3 Inhibition of Lambda closed loop control

Output data:

Name	Mode	Hex. limits	Phys. limits	Resol.	Unit
T_DLY_LAM_TQR	V	0...FFH	0...25.5	0.1	s
delay time for lambda control activation after cylinder shut-off for torque intervention					
LV_SCC_LAM_TQR	V	0...1H	0...1	1	-
Boolean for Lambda control loop opened due to cylinder shut-off for torque intervention					

Input data:

LV_SCC_TQR			
------------	--	--	--

General Information:

During cylinder shut-off phases due to torque reduction (LV_SCC_TQR = 1) the closed loop lambda control is stopped immediately and LV_SCC_LAM_TQR is set. When the cylinder shut-off mode is ended (LV_SCC_TQR = 0), the timer T_DLY_LAM_TQR is started with C_T_DLY_LAM_TQR. As soon as this timer has run out, LV_SCC_LAM_TQR is reset.

Formula Section:

If LV_SCC_TQR = 1
then LV_SCC_LAM_TQR = 1

If LV_SCC_TQR = 0
and T_DLY_LAM_TQR = 0
then LV_SCC_LAM_TQR = 0

Calibration data:

Name	Dim	Hex. limits	Phys. limits	Resol.	Unit
C_T_DLY_LAM_TQR	1	0...FFH	0...25.5	0.1	s
delay time for lambda control activation after cylinder shut-off for torque intervention					

Proprietary data, company confidential. All rights reserved. Contine a titre de secret d'entreprise. Tous droits réservés. Comunicado como segredo empresarial. Reservados todos os direitos. Confidado como secreto industrial. Nos reservamos todos los derechos.

Weitergabe sowie Vervielfältigung dieser Unterlage, Verwertung und Mitteilung ihres Inhalts nicht gestattet, soweit nicht ausdrücklich zugestanden. Zuwiderhandlungen verpflichten zu Schadensersatz. Alle Rechte vorbehalten, insbesondere für den Fall der Patenterteilung oder GM-Entragung.

Editor: Müller O.	17-Dec-97	Auxiliary functions	HMC_V6
Version: a 153589 from 18.12.97		657765.49.08	
File: CHAP_9.DOC	650H0000	Sourcefile:07901301.00B	Page 111 / 120

8.7.4 Inhibition of EGR during Cylinder Shut-Off

Output data:

Name	Mode	Hex. limits	Phys. limits	Resol.	Unit
T_DLY_EGR_TQR	V	0...FFH	0...25.5	0.1	s
delay time for EGR valve opening after cylinder shut-off for torque intervention					
LV_SCC_EGR_TQR	V	0...1H	0...1	1	-
Boolean for EGR valve closed due to cylinder shut-off for torque intervention					

Input data:

LV_SCC_TQR			
------------	--	--	--

During fuel cut-off phases due to torque reduction (LV_SCC_TQR = 1) the EGR has to be closed suddenly.

After fuel cut-off action the EGR-valve is opened after a delay time **C_T_DLY_EGR_TQR**.

Formula Section:

If LV_SCC_TQR = 1
then LV_SCC_EGR_TQR = 1

If LV_SCC_TQR = 0
and T_DLY_EGR_TQR = 0
then LV_SCC_EGR_TQR = 0

Calibration data:

Name	Dim	Hex. limits	Phys. limits	Resol.	Unit
C_T_DLY_EGR_TQR	1	0...FFH	0...25.5	0.1	s
delay time for EGR valve opening after cylinder shut-off for torque intervention					

Proprietary data, company confidential. All rights reserved.
 Contient des informations confidentielles de la société. Tous droits réservés.
 Comunicado como segredo empresarial. Reservados todos os direitos.
 Confidado como secreto industrial. Nos reservamos todos los derechos.

Weitergabe sowie Vervielfältigung dieser Unterlage, Verwertung und Mitteilung ihres Inhalts ist gestattet, soweit nicht ausdrücklich zugestanden. Zuwiderhandlungen verpflichten zu Schadensersatz. Alle Rechte vorbehalten, insbesondere für den Fall der Patenterteilung oder GM-Entragung.

Editor: Müller O.	17-Dec-97	Auxiliary functions	HMC_V6
Version: a 153589 from 18.12.97		657765.49.08	
File: CHAP_9.DOC	650H0000	Sourcefile:07901301.00B	Page 112 / 120

8.7.5 Cylinder-specific fuel mixture enrichment on restarting fuel-feed

Output data:

Name	Mode	Hex. limits	Phys. limits	Resol.	Unit
TI_ADD_REAC_SCC_[CYL]	V	0...FFFFH	0...262.14	0.004	ms
fuel enrichment for restarting cylinders					
TI_DIF_WF_[CYL]	V	0...FFFFH	-131.07...131.07	0.004	ms
calculated amount of wall film					

Input data:

TIB	TCO	N_32	
-----	-----	------	--

General information:

In order to provide a sufficient fuel feed when reactivating a cylinder after a shut-off (complete combustion without misfire) and to ensure a fast torque build-up, the cylinder is supplied with an additional fuel quantity:

- To consider the increased cylinder fill due to the lack of residual exhaust gas
- To consider the removal of the wall-applied fuel film during cylinder shut-off

The additional fuel quantity is calculated individually for each re-activated cylinder. When the cylinder is restarted, there is no difference depending on the previous operating states.

Formula section:

$$\begin{aligned}
 TI = & : \\
 & : \\
 & + TI_ADD_REAC_SCC_ [CYL]
 \end{aligned}$$

Proprietary data, company confidential. All rights reserved. Contient a titre de secret d'entreprise. Tous droits réservés. Comunicado como segredo empresarial. Reservados todos os direitos. Confidado como secreto industrial. Nos reservamos todos los derechos.

Weitergabe sowie Vervielfältigung dieser Unterlage, Verwertung und Mitteilung ihres Inhalts ist gestattet, soweit nicht ausdrücklich zugestanden. Zuwiderhandlungen verpflichten zu Schadensersatz. Alle Rechte vorbehalten, insbesondere für den Fall der Patenterteilung oder GM-Enttragung.

Editor: Müller O.	17-Dec-97	Auxiliary functions	HMC_V6
Version: a 153589 from 18.12.97		657765.49.08	
File: CHAP_9.DOC	650H0000	Sourcefile:07901301.00B	Page 113 / 120

Proprietary data, company confidential. All rights reserved. Contient des informations confidentielles. Tous droits réservés. Comunicado como segredo empresarial. Reservados todos os direitos. Confidado como secreto industrial. Nos reservamos todos los derechos.

Weitergabe sowie Vervielfältigung dieser Unterlage, Verbreitung und Mitteilung ihres Inhalts nicht gestattet, soweit nicht ausdrücklich zugestanden. Zuwiderhandlungen verpflichten zu Schadenersatz. Alle Rechte vorbehalten, insbesondere für den Fall der Patenterteilung oder GM-Entragung.

8.7.5.1 Calculation of the Wall-Applied Fuel Film Removal

To simulate the wall-applied fuel film removal, the cylinder-specific variable **TI_DIF_WF_[CYL]** is used. When the cylinder is shut off, **TI_DIF_WF_[CYL]** is set to the current negative basic injection period **TIB**, which is multiplied by the adjustable factor **ID_TI_TCO_NEG_WF_TCO**.

As long as the cylinder is shut off, an engine-speed related additional fuel quantity **ID_TI_INC_WF_N_32** is incremented cyclically at intervals of 720° CRK, until either the cylinder is reactivated or the wall film is completely removed.

Directly after cylinder shut-off:

$$TI_DIF_WF_ [CYL] = - TIB * ID_TI_TCO_NEG_WF_TCO$$

During the following cylinder shut-off period:

$$TI_DIF_WF_ [CYL]_k = TI_DIF_WF_ [CYL]_{k-1} + ID_TI_INC_WF_N_32$$

8.7.5.2 Additional Injection Quantity for Re-Activation of the Cylinder

The fuel quantity represented by **TI_ADD_REAC_SCC_[CYL]** is provided additionally as restart fuel feed for each cylinder. It is calculated based on the simulated wall-applied fuel film portion **TI_DIF_WF_[CYL]** and the current basic injection time **TIB**, multiplied by the basic amount of fuel at restarting **ID_TI_TCO_POS_WF_TCO**.

Because of the higher load of the restarting cylinders due to missing residual gas, every first restart cycle an additional amount of fuel **ID_TI_N_POS_RG_N_32** is injected.

For the restart fuel reduction which is calculated during cylinder shut-off, an engine-speed related decrement **ID_TI_DEC_WF_N_32** is used until the additional reactivation amount **TI_ADD_REAC_SCC_[CYL]_k** is decremented to zero.

$$\begin{aligned}
 TI_ADD_REAC_SCC_ [CYL] &= TI_DIF_WF_ [CYL] \\
 &+ TIB * ID_TI_TCO_POS_WF_TCO \\
 &+ ID_TI_N_POS_RG \quad (applied\ only\ for\ first\ restart\ cycle)
 \end{aligned}$$

$$TI_ADD_REAC_SCC_ [CYL]_k = TI_ADD_REAC_SCC_ [CYL]_{k-1} - ID_TI_DEC_WF_N_32$$

Editor: Müller O.	17-Dec-97	Auxiliary functions	HMC_V6
Version: a 153589 from 18.12.97		657765.49.08	
File: CHAP_9.DOC	650H0000	Sourcefile:07901301.00B	Page 114 / 120

8.7.5.3 Case studies

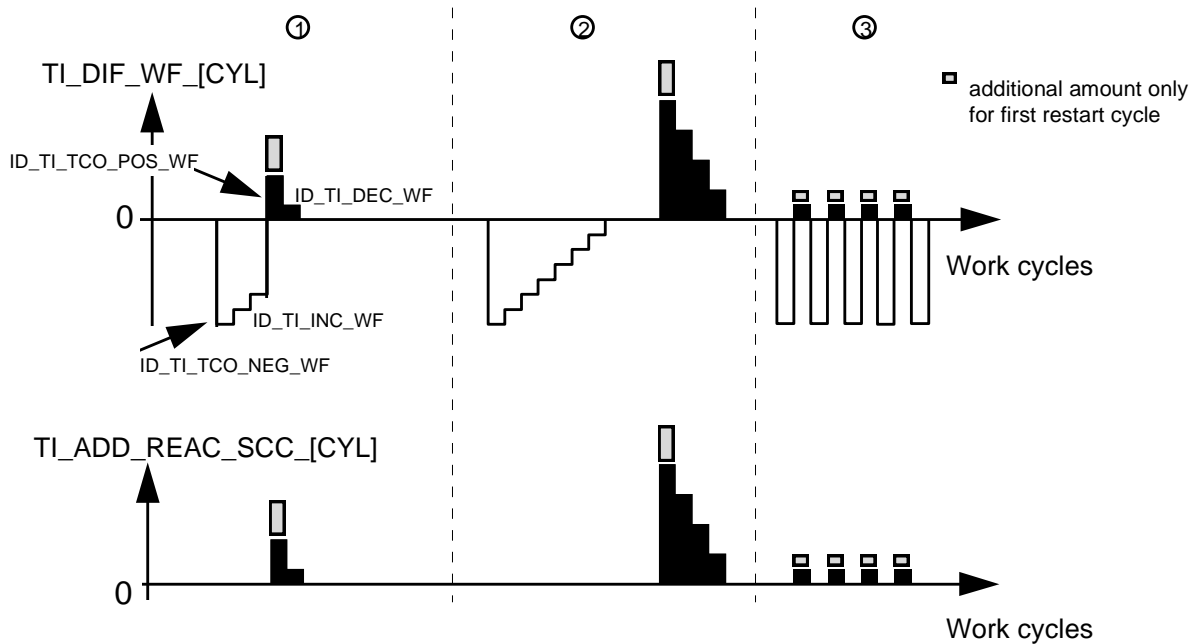

Case 1:

In this example the cylinder is activated again after three shut-off cycles. The wall-applied fuel film has not been removed completely. Therefore the re-starting fuel quantity TI_ADD_REAC_SCC_[CYL] takes into account the residual wall film as a negative value represented by TI_DIF_WF_[CYL]. The additional reactivation injection quantity TI_ADD_REAC_SCC_[CYL] is reset after two cycles.

Case 2:

After a longer cylinder shut-off the wall-applied fuel film is removed completely. The cylinder is re-activated with the maximum quantity for TI_ADD_REAC_SCC_[CYL]

Case 3:

This example shows alternating cylinder operation. Here an additional injection quantity is supplied with every combustion cycle.

Calibration data:

Name	Dim	Hex. limits	Phys. limits	Resol.	Unit
ID_TI_INC_WF__N_32	8	0...FFFFH	0...262.14	0.004	ms
increase of wall film					
ID_TI_DEC_WF__N_32	8	0...FFFFH	0...262.14	0.004	ms
decrease of wall film					
ID_TI_TCO_POS_WF__TCO	8	0...FFFFH	0...4	0.00006	-
basic amount of fuel at restarting					
ID_TI_TCO_NEG_WF__TCO	8	0...FFFFH	0...4	0.00006	-
basic amount of wall film					
ID_TI_N_POS_RG__N_32	8	0...FFFFH	0...262.14	0.004	ms
Residual exhaust gas compensation					

Editor: Müller O.	17-Dec-97	Auxiliary functions	HMC_V6
Version: a 153589 from 18.12.97		657765.49.08	
File: CHAP_9.DOC	650H0000	Sourcefile:07901301.00B	Page 115 / 120

Proprietary data, company confidential. All rights reserved.
 Contiene información confidencial. Todos los derechos reservados.
 Contém dados da empresa, propriedade intelectual. Reservados todos os direitos.
 Comunicado como segredo empresarial. Reservados todos os direitos.
 Confidado como secreto industrial. Nos reservamos todos los derechos.

Weitergabe sowie Vervielfältigung dieser Unterlage, Verwertung und Mitteilung ihres Inhalts ist gestattet, soweit nicht ausdrücklich zugestanden. Zuwiderhandlungen verpflichten zu Schadensersatz. Alle Rechte vorbehalten, insbesondere für den Fall der Patenterteilung oder GM-Enttragung.

8.8 Torque during an torque intervention (TQI_INTV)

Output data:

Name	Mode	Hex. limits	Phys. limits	Resol.	Unit
TQI_INTV	V	0...FFH	0...510	2	Nm
indicated engine torque during torque reduction intervention					

Input data:

IP_TQI_N_32_MAF	IP_FAC_LAM_TQI_LAM_S UB_IGA_DIF_REF_AV	TQR_REL_SCC_AV	TQR_REL_IGA_AV
LV_ES			

The variable **TQI_INTV** represents the indicated engine torque during a torque reduction intervention.

Application conditions:

Activation: not ES

Deactivation: ES

Formula section:

$$\begin{aligned}
 \text{TQI_INTV} &= \text{IP_TQI_N_32_MAF} && \text{(indicated engine torque)} \\
 & * \text{IP_FAC_LAM_TQI_LAM_SUB_IGA_DIF_REF_AV} && \text{(lambda correction)} \\
 & * [1 - (\text{TQR_REL_SCC_AV} && \text{(torque reduction by the actual cylinder shut-off)} \\
 & \quad + \text{TQR_REL_IGA_AV})] && \text{(torque reduction by the ignition angle adjustment)}
 \end{aligned}$$

Proprietary data, company confidential. All rights reserved. Contine a titre de secret d'entreprise. Tous droits réservés. Comunicado como segredo empresarial. Reservados todos os direitos. Confidado como secreto industrial. Nos reservamos todos los derechos.

Weitergabe sowie Vervielfältigung dieser Unterlage, Verwertung und Mitteilung ihres Inhalts nicht gestattet, soweit nicht ausdrücklich zugestanden. Zuwiderhandlungen verpflichten zu Schadensersatz. Alle Rechte vorbehalten, insbesondere für den Fall der Patenterteilung oder GM-Enttragung.

Editor: Müller O.	17-Dec-97	Auxiliary functions	HMC_V6
Version: a 153589 from 18.12.97		657765.49.08	
File: CHAP_9.DOC	650H0000	Sourcefile:07901301.00B	Page 116 / 120

8.9 ASR Statistics Counters

Output data:

Name	Mode	Hex. limits	Phys. limits	Resol.	Unit
T_SCC_S	V	0...1770H	0...60	0.01	s
short time counter for SCC					
T_SCC_L	V	0...FFFFH	0...65535	1	min
long time counter for SCC					
ASR_STAT_0...15	V	0...FFFFH	0...65535	1	
ASR statistical array					
T_ASR_CTR	V	0...FFFFH	0...65535	1	s
ASR statistical counter					
TQR_ASR_MAX	V	0...FFH	0...255	1	%
depth of ASR intervention					

Input data:

TQR_REL_ASR_NV	TQR_REL_SCC_AV		
----------------	----------------	--	--

8.9.1 Cylinder Shut-Off Time Counter T_SCC_S and T_SCC_L

The cylinder shut-off time counter records all cylinder shut-off periods resulting from ASR requests. It is to demonstrate the connection between the cylinder shut-off period and the extent of additional aging of the catalytic converter.

There are two counters:

- a) The short-time counter **T_SCC_S** (0...60 sec) is incremented in steps of 10 ms and reset to zero each 60 sec
- b) The long-time counter **T_SCC_L** (0...65535 min) is incremented in steps of one.

The contents of both the counters are stored in the EEPROM and are available after the ignition is switched off.

Reset:

The contents of the SCC time counter can be reset to zero by the procedure resetting the adaptation values via SAMS 2000 application tool.

Enabling condition for SCC time counter:

TQR_REL_SCC_AV > 0

In this context, the value of the ignition angle intervention **TQR_REL_IGA_AV** is not considered.

Proprietary data, company confidential. All rights reserved. Contine a titre de secret d'entreprise. Tous droits réservés. Comunicado como segredo empresarial. Reservados todos os direitos. Confidado como secreto industrial. Nos reservamos todos los derechos.

Weitergabe sowie Vervielfältigung dieser Unterlage, Verwertung und Mitteilung ihres Inhalts nicht gestattet, soweit nicht ausdrücklich zugestanden. Zuwiderhandlungen verpflichten zu Schadensersatz. Alle Rechte vorbehalten, insbesondere für den Fall der Patenterteilung oder Gm-Entragung.

Editor: Müller O.	17-Dec-97	Auxiliary functions	HMC_V6
Version: a 153589 from 18.12.97		657765.49.08	
File: CHAP_9.DOC	650H0000	Sourcefile:07901301.00B	Page 117 / 120

Proprietary data, company confidential. All rights reserved.
 Contit a titre de secret d'entreprise. Tous droits réservés.
 Comunicado como secreto empresarial. Reservados todos os direitos.
 Confidado como secreto industrial. Nos reservamos todos los derechos.

Weitergabe sowie Vervielfältigung dieser Unterlage, Verwertung und Mitteilung ihres Inhalts nicht gestattet, soweit nicht ausdrücklich zugestanden. Zuwiderhandlungen verpflichten zu Schadenersatz. Alle Rechte vorbehalten, insbesondere für den Fall der Patenterteilung oder GM-Entragung.

8.9.2 Event Frequency Counter - Intervention Statistics ASR_STAT_0...15

16 event frequency counters **ASR_STAT_0...15** which are arranged in the form of a 4x4 matrix array record ASR requests by their duration and depth of action.

The measure of the depth of action **TQR_ASR_MAX** is the requested torque reduction **TQR_REL_ASR_NV**. The duration of intervention is recorded by the ASR time counter **T_ASR_CTR** (resolution: 10 ms), which starts beginning with a valid ASR request (**TQR_REL_ASR_NV > 0**) and is stopped when the ASR request is terminated (**TQR_REL_ASR_NV = 0**).

During an active ASR phase, the maximum of (**TQR_REL_IGA_AV + TQR_REL_SCC_AV**) is stored. Once the ASR intervention is terminated, the maximum of **TQR_REL_IGA_AV** and **TQR_REL_SCC_AV** as well as **T_ASR_CTR** are stored in the array. If the maximum of 255 is reached for **T_ASR_CTR**, it remains unchanged until it is reset by hand.

Reset:

The contents of the statistic counter can be reset to zero by the procedure resetting the adaptation values via SAMS 2000 application tool.

The data points of the event frequency counter cannot be adjusted in the scope of the application, only via a software intervention.

Arrangement of event frequency counters

Depth of action TQR TQR_ASR_MAX	ASR_CAN_STAT_0...15			
0% ... < 25%	_0	_1	_2	_3
25% ... < 50%	_4	_5	_6	_7
50% ... < 75%	_8	_9	_10	_11
→ 75 %	_12	_13	_14	_15
Duration of intervention in sec T_ASR_CTR	0...0.5	> 0.5 ... 2	> 2 ... 8	> 8

Editor: Müller O.	17-Dec-97	Auxiliary functions	HMC_V6
Version: a 153589 from 18.12.97		657765.49.08	
File: CHAP_9.DOC	650H0000	Sourcefile:07901301.00B	Page 118 / 120

8.10 Torque Reduction Emergency Operation

Output data:

Name	Mode	Hex. limits	Phys. limits	Resol.	Unit
T_DLY_DIAG_TQR	V	0...FFH	0...2.55	0.01	s
delay time for starting the emergency ramp					

If a transmission error or a mixture-related component error (MAF-Sensor, Canister purge valve, injection valves ...) occurs during an active torque reduction phase, the current torque reduction is continued for the time **T_DLY_DIAG_TQR** and subsequently reset to **TQR_REL_NV = 0** using **LGRD_TQR_DEC_DIAG**.

The emergency operation is carried out if an error is detect on one of the following components:

- Injection valve
- MAF-sensor
- Canister purge valve
- CAN component (bus-off or timeout)

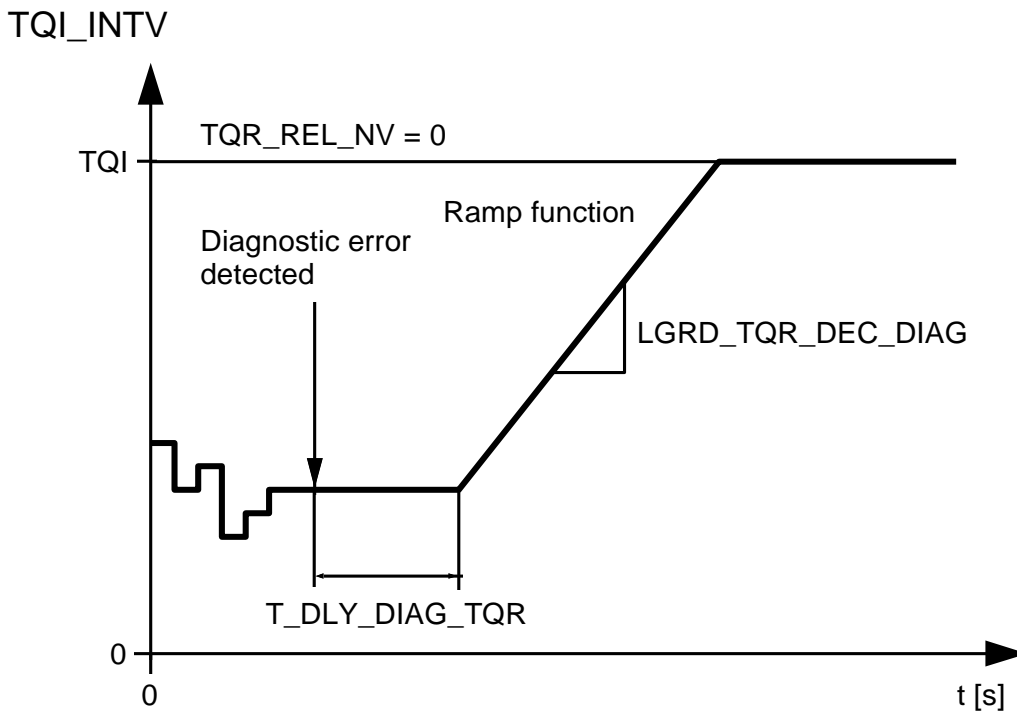

Calibration data:

Name	Dim	Hex. limits	Phys. limits	Resol.	Unit
C_LGRD_TQR_DEC_DIAG	1	1...FFH	0.004...1.02	0.04	1/100ms
limiting gradient for TQR-emergency ramp					
C_T_DLY_DIAG_TQR	1	0...FFH	0...2.55	0.01	s
delay time for emergency ramp					

Editor: Müller O.	17-Dec-97	Auxiliary functions	HMC_V6
Version: a 153589 from 18.12.97		657765.49.08	
File: CHAP_9.DOC	650H0000	Sourcefile:07901301.00B	Page 119 / 120

Proprietary data, company confidential. All rights reserved. Contine a titre de secret d'entreprise. Tous droits réservés. Comunicado como segredo empresarial. Reservados todos os direitos. Confidado como secreto industrial. Nos reservamos todos los derechos.

Weitergabe sowie Vervielfältigung dieser Unterlage, Wertung und Mitteilung ihres Inhalts nicht gestattet, soweit nicht ausdrücklich zugestanden. Zuwiderhandlungen verpflichten zu Schadensersatz. Alle Rechte vorbehalten, insbesondere für den Fall der Patenterteilung oder GM-Enttragung.

9 Fuel pump relay control

Input data:

LV_ES	LV_IGK		
-------	--------	--	--

FUNCTION DESCRIPTION:

General information:

The fuel pump is switched **ON** for **4 sec.** during the transition from the control unit initialization to engine operating state engine stopped (LV_ES = 1) with ignition key **ON** (LV_IGK = active).

Following ignition key **OFF** (LV_IGK = passive), the fuel pump is switched **OFF** after a waiting period C_T_EFP.

Description:

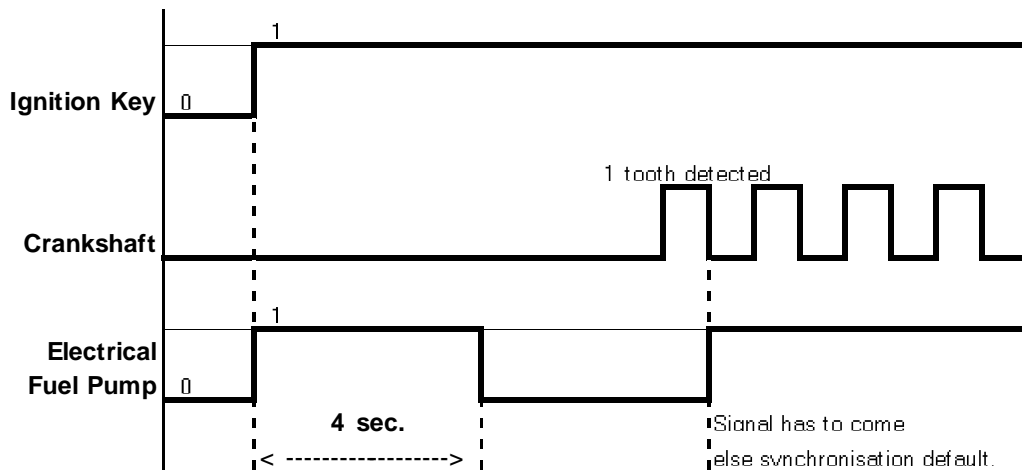

Calibration data:

Name	Type	Dim	Hex. limits	Phys. limits	Resol.	Unit
C_T_EFP	2U	1	01... FFFFH	0,1... 6553,5	0,1	sec.
Time delay to shut - off the electric fuel pump relay after ignition key OFF.						

Editor: Müller O.	17-Dec-97	Auxiliary functions	HMC_V6
Version: a 153589 from 18.12.97		657765.49.08	
File: CHAP_9.DOC	650H0000	Sourcefile:07901401.00A	Page 120 / 120